

# AJ977XF+



## Anti-Jam Multi-Constellation Triple-Band Antenna

Frequency Coverage: GPS & QZSS L1, L2, L5 | GALILEO E1, E5a, E5b | BEIDOU B1, B2a, B2b | GLONASS G1, G2, G3 | NavIC L5

The AJ977XF+ supports GPS/QZSS-L1/L2/L5, GLONASS-G1/G2/G3, Galileo-E1/E5a/E5b, BeiDou-B1/B2b/B2a, and NavIC-L5 frequency bands, including the satellite-based augmentation system (SBAS) available in the region of operation [WAAS (North America), EGNOS (Europe), MSAS (Japan), or GAGAN (India)].

The AJ977XF+ Anti Jam antenna is designed to mitigate interference and jamming signals broadcast from near ground-based transmitters. The radiation pattern of the Low Elevation Angle Nulling Antenna (LEANA) provides 20 dB (typical) wideband suppression for all GNSS band signals received at an elevation angle of 0° through to approximately 15°. This level of attenuation was demonstrated to mitigate jamming signal broadcasts at an elevation angle of 10° such that the AJ977XF+ can be up to 10 times closer, compared to a standard HC977XF helical antenna, to the source of interference without being jammed. The combination of Calian's low elevation angle nulling radiation pattern and eXtended Filtering (deep filtering and high linearity) technologies provides a one-two punch to jamming and RF noise. At the same time the AJ977XF+'s radiation pattern above 20° elevation angle provides excellent gain and a phase center that supports accurate and precise positioning.

Calian's eXtended Filtering+ (XF+) technology features > 80 dB of out-of-band rejection from 700MHz to 2500MHz and separates the LNA's upper and lower signal amplification channels; if one is channel is jammed the other remains usable. In North America, Ligado signals at 1525 - 1536 MHz can especially impact GNSS antennas that support space-based L-band correction services (1539 - 1559 MHz). New LTE signals in Europe [Band 32 (1452 - 1496 MHz)] and Japan [Bands 11 and 21 (1476 - 1511 MHz)] have also been observed to interfere with GNSS signals. In addition, Inmarsat satellite communication (uplink: 1626.5 - 1660.5 MHz) can also affect GNSS signals. Calian's custom XF filtering mitigates all existing signals and new Ligado and LTE signals, enabling the antennas and attached GNSS receivers to perform optimally.

The Tallysman AJ977XF+ antenna is ideal of all mission critical positioning, navigation and timing applications.



### Applications

- Mission-critical global positioning
- Timing applications
- Law enforcement and public safety

### Features

- Great axial ratio (1.0 dB typ.)
- Low LNA noise (2.5 dB typ.)
- High-rejection XF+ Filtering
- High-gain LNA (40 dB typ.)
- Wide voltage input range (2.5 to 16 VDC)
- ESD circuit protection (15 kV)
- IP67 weather-proof housing
- RoHS and REACH compliant
- 20 dB attenuation at 0-15° Elevation

### Benefits

- Operates under ground-based jamming
- Circular polarisation throughout the full bandwidth
- Superior multipath signal rejection
- Excellent signal-to-noise ratio
- Excellent out-of-band signal rejection
- Increased system accuracy
- Ideal for noisy RF environments

**About Calian:** With global headquarters and manufacturing in Ottawa, Canada, Calian is a leading manufacturer of high-precision antennas and components for Global Navigation Satellite System (GNSS) applications. Calian's mission is to support the needs of a new generation of positioning systems by delivering unprecedented antenna precision at competitive prices. Learn more at [www.calian.com/gnss](http://www.calian.com/gnss)

Revision: 202506

Contact us:  
[info.gnss@calian.com](mailto:info.gnss@calian.com)  
T: +1 613 591-3131

# Anti-Jam Multi-Constellation Triple-Band Antenna

Frequency Coverage: GPS & QZSS L1, L2, L5 | GALILEO E1, E5a, E5b | BEIDOU B1, B2a, B2b | GLONASS G1, G2, G3 | NavIC L5

## Antenna

Technology Triple-frequency, RHCP quadrifilar helix

GNSS		Gain	Axial Ratio
		dBic typ. at Zenith	dB at Zenith
GPS / QZSS	L1	2.5	≤ 1.0
	L2	3.7	≤ 1.0
	L5	1.9	≤ 1.0
GLONASS	G1	1.8	≤ 1.0
	G2	3.0	≤ 1.0
	G3	3.0	≤ 1.0
Galileo	E1	2.5	≤ 1.0
	E5A	1.9	≤ 1.0
	E5B	3.0	≤ 1.0
	E6	-	-
BeiDou	B1	2.5	≤ 1.0
	B2b	3.3	≤ 1.0
	B2a	1.9	≤ 1.0
	B3	-	-
IRNSS / NavIC	L5	1.9	≤ 1.0
QZSS	L6	-	-
L-Band Services (1525 MHz - 1559 MHz)		-	-
Satellite Communications			
Iridium		-	-
Globalstar		-	-
Other			
Axial Ratio at 10°	-	Efficiency	-
PC Variation	-	PCO	-

## Mechanicals

Size	90.0 mm (dia.) x 180 mm (h.)
Weight	245 g
Radome	Radome: EXL9330 , Base: Aluminum
Mount	Through-hole
Available Connectors	TNC or type-N (female)

## Environmental

Operating Temperature	-40 °C to + 85 °C
Storage Temperature	-50 °C to + 95 °C
Vibration	MIL-STD-810D Method 514.3-1
Shock	Vertical axis: 50 G, other axes: 30 G
Salt Fog	-
IP Rating	IP67
Compliance	IPC-A-610, FCC, RED / CE Mark, RoHS, REACH

## Warranty

Parts and Labour	3-year standard warranty
------------------	--------------------------

## Low Noise Amplifier (LNA) - Measured at 3V and 25°C

Frequency Bandwidth	Out of Band Rejection
Lower Band	1164 -1254 MHz
L-Band Corr.	-
Upper Band	1559 - 1606 MHz

> 85dB @ < 1100 MHz
> 82dB @ > 1300 MHz
> 90dB @ < 1325 MHz
> 75 dB @ < 1526 MHz
> 47 dB @ < 1536 MHz
> 35 db @ > 1626 MHz
> 90 dB @ > 1700 MHz

Architecture	eXtended Filtering+
Gain	40 dB typ.
Noise Figure	2.5 dB typ.
VSWR	< 1.5:1 typ., 1.8:1 max.
Supply Voltage Range	2.5 to 16 VDC nominal (12 VDC rec. max..)
Supply Current	17 mA typ.
ESD Circuit Protection	15 kV air discharge
P 1dB Output	7 dBm typ.
Group Delay	10 ns (L1), 4 ns (L2), 11 ns (L5)

## Mechanical Diagram

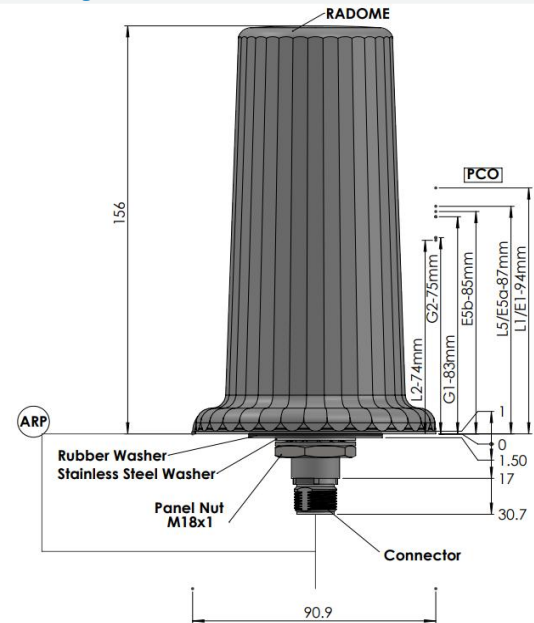

## Ordering Information

Part Number **33-AJ977XF+-xx**

where xx = connector type, 01 = TNC (female), 14 = type-N (female)

Please refer to our **Ordering Guide** to review available radomes and connectors at:  
<https://at.calian.com/gnss/information-support/part-number-ordering-guide/>