

Navsight Solution

Inertial Systems for Survey Applications

Hardware Manual



Document
Revision

NAVSIGHTHM.1.5
1.5 - Nov 30, 2022

Support

EMEA

support@sbg-systems.com
+33 1 80 88 43 70

Americas

support@sbg-systems.com
+1 (657) 549-5807

Revision history

Rev.	Date	Author	Information
1.5	Nov 30, 2022	Mathieu Peyréga	[NAVDOC-32] - Navsight rack Sync Out A pinout missing [NAVDOC-33] - Various typo and formatting issues [NAVDOC-34] - Fix acronyms list [NAVDOC-35] - Update manual and hardware specs to reflect [CR-27] [NAVDOC-36] - Fix Navsight typical automotive application sketch [NAVDOC-37] - Change mass and power consumption [NAVDOC-38] - Fix Subsea Apogee dimensions [NAVDOC-39] - Add information on maximum number of pulses per second that the HPI can receive from the Odometer
1.4	Jun 14, 2022	Alexis Guinamard	[NAVDOC-23] Update transport cases accessories [NAVDOC-21] Fixed Serial port description typos [NAVDOC-25] Update serial port specifications (Tx/Rx) [NAVDOC-26] Fixed Ship Motion HP latency to 150s [NAVDOC-27] Specify RTK performance according to baseline [NAVDOC-29] Update orientation specifications after algorithms update [NAVDOC-30] Transferred antennas section to support center [NAVDOC-31] Added Asterx-m3 specifications
1.3	Jul 2, 2020	Alexis Guinamard	[NAVDOC-18] Update heading performance for FW 3.0 [NAVDOC-16] Updated data logger LED documentation [NAVDOC-15] Updated PPP Correction services on NAVSIGHT-5
1.2	Sep 19, 2019	Alexis Guinamard	[NAVDOC-11] Added new Trimble GNSS receiver specifications [NAVDOC-10] Added new Apogee IMU product codes (V2) [NAVDOC-13] Added IMU sensor specifications [NAVDOC-12] Add virtual odometer feature [NAVDOC-14] Updated product codes and part numbers
1.1	Feb 13, 2019	Alexis Guinamard	[NAVDOC-7] Add maximum cable length specifications [NAVDOC-6] Add CA-SPLIT-COM cable description [NAVDOC-4] Added information about supported RTK corrections formats [NAVDOC-1] Add Horizon IMU specifications [NAVDOC-3] Add Rack mount processing unit specifications [NAVDOC-8] Added electrical specifications of various modules [NAVDOC-9] Added IMU connector specifications
1.0	Sep 28, 2018	Alexis Guinamard	First official version

© 2007 – 2022 SBG Systems SAS. All rights reserved. Information in this document is subject to change without notice. Copy or redistribution of this document is forbidden without express authorization of SBG Systems.

Index

- 1. Terminology..... 7**
- 2. Solution overview..... 8**
 - 2.1. System..... 9
 - 2.2. IMU..... 9
 - 2.2.1. Ekinox IMU..... 9
 - 2.2.1.1. Accelerometers..... 9
 - 2.2.1.2. Gyroscopes..... 10
 - 2.2.1.3. Surface form factor..... 10
 - 2.2.1.4. Subsea form factor..... 12
 - 2.2.2. Apogee IMU..... 13
 - 2.2.2.1. Accelerometers..... 13
 - 2.2.2.2. Gyroscopes..... 13
 - 2.2.2.3. Surface form factor..... 13
 - 2.2.2.4. Subsea form factor..... 15
 - 2.2.3. Horizon IMU..... 16
 - 2.2.3.1. Accelerometers..... 16
 - 2.2.3.2. Gyroscopes..... 16
 - 2.2.3.3. Surface form factor..... 16
 - 2.2.4. Specifications..... 17
 - 2.3. Navsight Processing unit..... 18
 - 2.3.1. Rugged packaging..... 18
 - 2.3.1.1. Mechanical specifications..... 18
 - 2.3.2. Rack packaging..... 19
 - 2.3.2.1. Mechanical specifications..... 19
 - 2.3.3. Internal GNSS (Septentrio Asterx-4, HW Revision <= 2.1)..... 20
 - 2.3.4. Internal GNSS (Septentrio Asterx-m3, HW Revision >= 2.1)..... 21
 - 2.3.5. Internal GNSS (Trimble, HW revision >= 1.5 and <= 2.1)..... 22
 - 2.3.6. Internal GNSS (Trimble, HW revision < 1.5)..... 23
- 3. System Performance specification..... 24**
 - 3.1. Ekinox grade performance specifications..... 24
 - 3.1.1. Common specifications..... 24
 - 3.1.2. Land applications..... 24
 - 3.1.3. Marine & Subsea applications..... 25
 - 3.1.3.1. Heave performance..... 25
 - 3.1.4. Airborne applications..... 25
 - 3.2. Apogee grade specifications..... 26
 - 3.2.1. Common specifications..... 26
 - 3.2.2. Marine & Subsea applications..... 26
 - 3.2.2.1. Heave performance..... 27
 - 3.2.3. Land applications..... 27
 - 3.2.4. Airborne applications..... 27
 - 3.3. Horizon grade specifications..... 28
 - 3.3.1. Marine applications..... 28
 - 3.3.1.1. Heave performance..... 28
 - 3.3.2. Land applications..... 29

3.3.3. Airborne applications.....	29
4. IMU interface specification.....	30
4.1. Surface IMU interfaces.....	30
4.2. Subsea IMU interfaces.....	30
5. Processing unit Interfaces specifications.....	31
5.1. Rugged version Overview.....	31
5.2. Rack version Overview.....	32
5.3. Interfacing capabilities.....	33
5.3.1. Supported protocols.....	33
5.4. Keyboard and LEDs indicators.....	34
5.4.1. LEDs status indicators.....	34
5.4.2. Buttons actions.....	35
5.4.2.1. Basic actions.....	35
5.4.2.2. Advanced actions.....	35
5.5. IMU interface.....	35
5.6. ETH interface.....	36
5.6.1. Accessing the Navsight web page.....	36
5.6.2. Connector specifications (rugged).....	36
5.6.3. Connector specifications (rack).....	37
5.7. CAN interface.....	37
5.7.1. Connector specifications (rugged).....	38
5.7.2. Connector specifications (rack).....	38
5.7.3. Electrical specifications.....	38
5.8. Serial ports interfaces.....	39
5.8.1. PORT A Interface.....	39
5.8.1.1. SYNC Out A functionality.....	39
5.8.1.2. Connector specifications (rugged).....	39
5.8.1.3. Connector specifications (rack).....	40
5.8.1.4. Electrical specifications.....	40
5.8.2. PORT B, C and D interfaces.....	41
5.8.2.1. Connector specifications (rugged).....	41
5.8.2.2. Connector specifications (rack).....	41
On the Rack version, the PORT B, C, D are accessible through a standard male DB-9 plug.....	41
5.8.2.3. Electrical specifications.....	42
5.8.3. PORT E interface.....	43
5.8.3.1. Connector specifications (rugged).....	43
5.8.3.2. Connector specifications (rack).....	44
On the Rack version, the PORT E is accessible through a standard male DB-9 plug.....	44
5.8.3.3. Electrical specifications.....	44
5.9. SYNC OUT B.....	45
5.9.1.1. Electrical specifications.....	45
5.10. SYNC In A, B, C, D and E.....	45
5.11. GNSS antenna connectors.....	46
5.11.1. Electrical specifications.....	46
5.11.2. GNSS antenna advice.....	46
5.12. Internal Datalogger.....	47
5.13. Power supply interface.....	47
5.13.1. Connector pin-out.....	47

- 5.13.2. Electrical specifications..... 48
- 5.14. Typical wiring recommendations..... 48
 - 5.14.1. Power supply connection..... 48
 - 5.14.2. Main interface connection on RS-232..... 49
 - 5.14.3. CAN Bus typical wiring..... 49
 - 5.14.4. GNSS connection in RS-232 mode..... 50
 - 5.14.5. Duplex interfacing in RS-422..... 50
- 5.15. Typical connection topology..... 51
 - 5.15.1. Navsight use in Land/Air survey applications..... 51
 - 5.15.2. Navsight use in marine applications..... 52
- 6. Important notices..... 53**
 - 6.1. Maintenance..... 53
 - 6.1.1. Subsea enclosures maintenance..... 53
 - 6.2. Absolute maximum ratings..... 53
 - 6.2.1. Processing units..... 53
 - 6.2.2. IMU modules..... 53
 - 6.3. Support..... 54
 - 6.4. Warranty, liability and return procedure..... 54
- 7. Appendix A: Ordering codes and Accessories..... 55**
 - 7.1. Ekinox IMU Ordering codes..... 55
 - 7.2. Apogee IMU Ordering codes..... 55
 - 7.3. Horizon IMU Ordering code..... 55
 - 7.4. Processing unit variants..... 56
 - 7.5. Transport Cases..... 57
 - 7.5.1. CASE-NAVS-04..... 57
 - 7.6. Associated Software..... 57
 - 7.6.1. Qinertia (Post-processing software)..... 57
 - 7.6.2. Inertial SDK (Software Development Kit)..... 57
 - 7.7. Cables..... 57
 - 7.7.1. IMU cables..... 57
 - 7.7.1.1. CA-NAVS-IMU-STD-#M..... 57
 - 7.7.1.2. CA-NAVS-IMU-SUB-#M..... 58
 - 7.7.1.3. CA-NAVS-IMU-EXT-#M..... 58
 - 7.7.2. CA-PWR-24-60-CC-4M..... 58
 - 7.7.3. CA-AEK-PWR-3M..... 59
 - 7.7.4. CA-NAVS-ETH-5M..... 59
 - 7.7.5. CA-NAVS-COM-2M..... 60
 - 7.7.6. CA-NAVS-COM-DB-0.3M..... 60
 - 7.7.7. CA-NAVS-SPLIT-COM-0.5M..... 61
- 8. Appendix B: Sub-systems mechanical outlines..... 62**
 - 8.1. Ekinox IMU – Surface enclosure..... 62
 - 8.1.1. Top View..... 62
 - 8.1.2. Right view..... 62
 - 8.1.3. Front view..... 63

- 8.1.4. Bottom view..... 63
- 8.2. Ekinox IMU – Subsea enclosure..... 64
 - 8.2.1. Top and bottom views..... 64
 - 8.2.2. Front view..... 64
- 8.3. Apogee IMU – Surface enclosure..... 65
 - 8.3.1. Top view..... 65
 - 8.3.2. Right view..... 65
 - 8.3.3. Front view..... 66
 - 8.3.4. Bottom view..... 66
- 8.4. Apogee IMU – Subsea enclosure..... 67
 - 8.4.1. Top and bottom views..... 67
 - 8.4.2. Front view..... 67
- 8.5. Horizon IMU..... 68
 - 8.5.1. Top view..... 68
 - 8.5.2. Right view..... 68
 - 8.5.3. Front view..... 69
 - 8.5.4. Bottom view..... 69
- 8.6. Processing unit – Rugged enclosure..... 70
 - 8.6.1. Top view..... 70
 - 8.6.2. Right view..... 70
 - 8.6.3. Front view..... 71
 - 8.6.4. Back view..... 71
- 8.7. Processing unit – Rack enclosure..... 72
 - 8.7.1. Top view..... 72
 - 8.7.2. Front view..... 72
 - 8.7.3. Back view..... 72
- 9. Appendix C: Products labels..... 73

1. Terminology

AHRS: Attitude and Heading Reference System

CAN (Bus): Controller Area Network

CMR: Compact Measurement Record (protocol)

DC: Direct Current

DGNSS: Differential GNSS

DMI: Distance Measuring Instrument

DVL: Doppler Velocity Log

EKF: Extended Kalman Filter

EMI: Electro Magnetic Interferences

FIR: Finite Impulse Response (filter)

FTP: File Transfer Protocol

GND: Ground

GNSS: Global Navigation Satellite System

GPS: Global Positioning System

IMU: Inertial Measurement Unit

INS: Inertial Navigation System

IP: Internet Protocol / Ingress Protection

LNA: Low Noise Amplifier

MEMS: Micro Electro-Mechanical Systems

MRU: Motion Reference Unit

MTBF: Mean Time Between Failures

NA: Not applicable

NMEA (NMEA 0183): National Marine Electronics Association (standardized communication protocol)

PPK: Post Processing Kinematic

PPS: Pulse Per Second (signal)

RoHS: Risk Of Hazardous Substance

RMA: Return Merchandise Authorization

RMS: Root Mean Square

RTCM: Radio Technical Commission for Maritime Services (Protocol)

RTK: Real Time Kinematics

SBAS: Satellite Based Augmentation System

SDK: Software Development Kit

SP: Single Point

TBD: To Be Defined

TCP: Transmission Control Protocol

UDP: User Datagram Protocol

UTC: Coordinated Universal Time

VRE: Vibration Rectification Error

WGS84: World Geodetic System 1984

2. Solution overview

Navsight is a comprehensive inertial navigation solution, specifically designed for the survey markets. Leveraging on existing SBG Systems inertial sensors, advanced algorithms and high performance GNSS technology, it also adds an incredibly easy to use setup.

Navsight solution is composed of various components that can be adjusted or configured according to your specific application needs:



Figure 2.1: The Navsight Rugged processing unit

The IMU is the main sensing element and the most important performance driving factor. In case of good GNSS conditions and shallow water or entry level land/air survey, the Ekinox IMU can be selected. In case of more challenging conditions, such as difficult GNSS environments, or high altitude / high depth survey, the Apogee grade is the sensor of choice to maintain the best accuracy. In case of airborne survey with single antenna setup, or more generally, for ultimate accuracy, the Horizon IMU should be selected. All IMUs are delivered in a rugged IP-68 package, and Ekinox / Apogee IMUs have optional salt water proof titanium enclosures.

The other main component is the processing unit. Available in a rugged IP-67 form factor or easy to integrate rack enclosure, it embeds all the navigation algorithms processing, a dual antenna, triple frequency GNSS receiver (optional), capable of PPP and centimetre precision using RTK, and all inputs and outputs interfaces. In addition to the standard Inertial Navigation System outputs (precise position, velocity and attitude), the marine variant of Navsight Processing unit also delivers precise heave and delayed heave. For some cost sensitive applications, it is also possible to select a simple MRU setup, with only roll, pitch, yaw and heave outputs.

For easier installation, the Navsight processing unit and IMU can be installed at different locations: IMU close to the location we want to track (eg. multibeam sonar), and processing unit, close to user. SBG Systems tested successfully installations with more than 50 m distance between processing unit and IMU.

The Navsight processing unit can be connected to a wide range of aiding sensors such as GNSS, DVL, Odometer.

To achieve the best performance in every project, specific error models have been implemented to meet applications requirements and to adapt the solution to your vehicle. Sensor configuration is made easy through the modern embedded web interface.

Finally, the 8 GB embedded data-logger enables seamless post processing work-flow with Qinertia software. This makes Navsight solution suitable for the most demanding applications.

Navsight solution is fully compatible with integrated Ekinox and Apogee series in terms of protocols, firmware and features.

2.1. System

The following diagram shows the basic organization of the Navsight solution. Internal GNSS receiver is optional.

The RS-485 link between IMU and processing unit allows secure and long distance communication (e.g. 50 m).

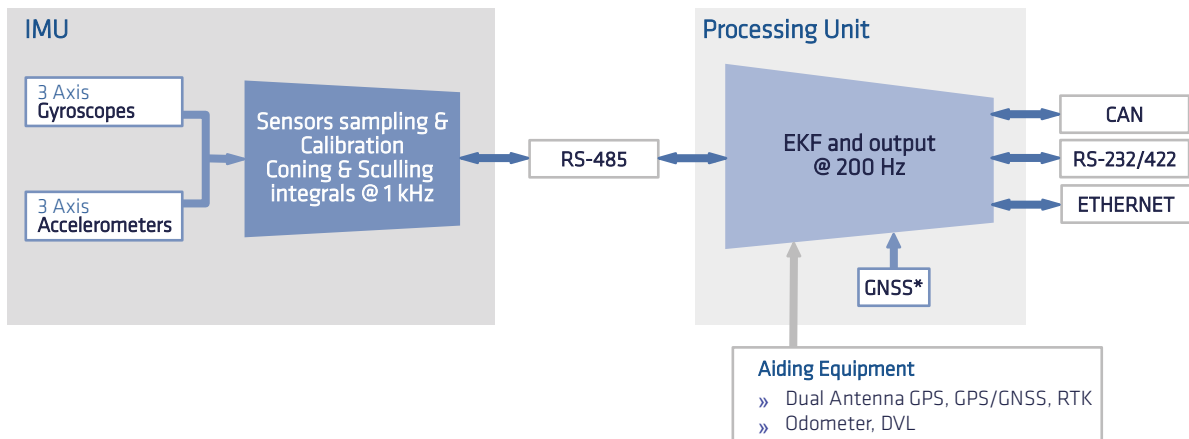

Figure 2.2: Navsight simplified block diagram

2.2. IMU

The IMU is the main component that will drive the overall system performance. Several IMU configurations are proposed to address different applications requirements.

2.2.1. Ekinox IMU

Ekinox IMU has been designed to deliver an exceptional performance in a very compact and cost effective package. Ekinox IMU integrates low noise gyroscopes. The integrated accelerometers are ultra low noise and highly efficient in vibrating environments due to a low Vibration Rectification Error. Sensor specifications are listed below.

2.2.1.1. Accelerometers

	A2	A3	Remarks
Full scale (g)	± 8	± 14	
Velocity Random Walk ($\mu g/\sqrt{Hz}$)	7	40	Allan variance - @ 25°C
In run bias instability (μg)	2	10	Allan variance - @ 25°C
Vibration Rectification Error ($\mu g/g^2$)	<200	<50	VRE - 20 Hz - 2 kHz
Bandwidth (Hz)	433	433	Attenuation of 3 dB
Orthogonality (°)	< 0.02	< 0.02	Over temperature range

2.2.1.2. Gyroscopes

	G4	Remarks
Full scale (°/s)	± 300	
In run bias instability (°/hr)	0.5	Allan variance – @ 25°C
Angular Random Walk (°/√hr)	0.14	Allan variance – @ 25°C
Bandwidth (Hz)	60	Attenuation of 3 dB
Orthogonality (°)	< 0.02	Over temperature range

2.2.1.3. Surface form factor

The Ekinox enclosure is composed of two anodized aluminum parts (6061), one for the cover and one for the base plate. The device uses high quality alloys and connectors to offer a full IP-68 enclosure and a good resistance to harsh environments.

The Ekinox IMU connector is a high quality push pull connector that offers IP-68 protection even unconnected.

Warning: The Ekinox IMU surface model is not designed for prolonged operation in salt water environments. Check section Maintenance for more details about operation in sea water environments.

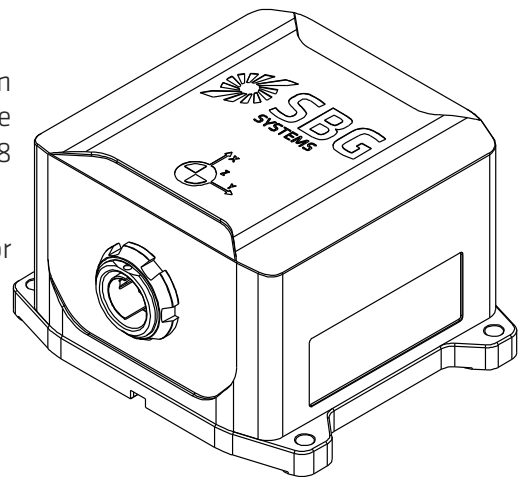

Figure 2.3: Ekinox Surface IMU

The table below summarizes all mechanical and environmental specifications.

Electrical and Mechanical Specifications	
Enclosure materials	Anodized Aluminum (6061)
Dimensions	5.8 x 10.0 x 8.6 cm
Weight	426 g
Input power voltage	12 – 36 V DC – isolated power supply
Power consumption	1.6 W typical.
Environmental specifications	
IP rating	IP-68 (24 hours at 1 meters)
Humidity	Sealed, no limit
Operating Temperature range	-20°C to 60°C – specified range -40°C to 71°C – operating range
Storage Temperature range	-40°C to 85°C
Shocks	500 g for 0.3 ms
Operating Vibrations	3 g RMS – 20 Hz to 2 kHz as per MIL-STD-810G (A2 range options) 8 g RMS – 20 Hz to 2 kHz as per MIL-STD-810G (A3 range options)
MTBF	50 000 hours
Calibration interval	None required, maintenance free

Device mechanical alignment

For best measurement accuracy, a good mechanical alignment is required. During manufacturing, the Ekinox IMU frame has been carefully aligned to 0.02° with the base plate for roll, pitch and yaw angles.

To ease the yaw alignment (X axis), the base plate features two alignment holes $\varnothing 4$ mm H8 that guarantees with two taper pins $\varnothing 4$ mm h7 a yaw alignment better than $\pm 0.04^\circ$.

Origin of measurements

The Ekinox IMU offers the possibility to output data at different measurement points.

The default center of measurement is located on top of Ekinox enclosure, on the coordinate frame center drawing. It is represented on the mechanical outlines by the  symbol. This point is defined to simplify installation.

Alternatively, user can select between two other center of measurement points:

- Alignment hole (aligned to the bottom of the base plate)
- Bare IMU center of measurement, represented by the  symbol.

2.2.1.4. Subsea form factor

The Ekinox IMU Subsea is composed of titanium parts, one for the cover and one for the base plate. The device uses a subsea connector to offer a depth rating of 200 m and good resistance to seawater environment.

Mechanical alignment

For best measurement accuracy, a good mechanical alignment is required. During manufacturing, the Apogee IMU frame has been carefully aligned to 0.02° with the base plate for roll, pitch and yaw.

To ease the yaw alignment (X axis), the base plate features two alignment holes Ø 4 mm H8 that guarantees with two taper pins Ø 4 mm h7 a yaw alignment better than ±0.04°.

Origin of measurements

The Ekinox IMU offers the possibility to output data at different measurement points. The default center of measurement is located on top of Ekinox enclosure, on the coordinate frame center drawing. It is represented on the mechanical outlines by the  symbol. This point is defined to simplify installation.

Alternatively, user can select between two other center of measurement points:

- Alignment hole (aligned to the bottom of the base plate)
- Bare IMU center of measurement, represented by the  symbol.

Specifications

The table below summarizes all mechanical and environmental specifications.

Electrical and Mechanical Specifications	
Enclosure materials	Titanium
Dimensions	Ø 9.2 x 7,0 cm
Weight in air	1.0 kg
Weight in water	0.86 kg
Input power voltage	12 – 36 V DC – isolated power supply
Power consumption	1.6 W typical.
Environmental specifications	
Depth rating	200 m
Humidity	Sealed, no limit
Operating Temperature range	-20°C to 60°C – specified range -40°C to 71°C – operating range
Storage Temperature range	-40°C to 85°C
Shocks	500 g for 0.3 ms
Operating Vibrations	3 g RMS – 20 Hz to 2 kHz as per MIL-STD-810G (A2 range options)
MTBF	50 000 hours
Calibration interval	None required, maintenance free

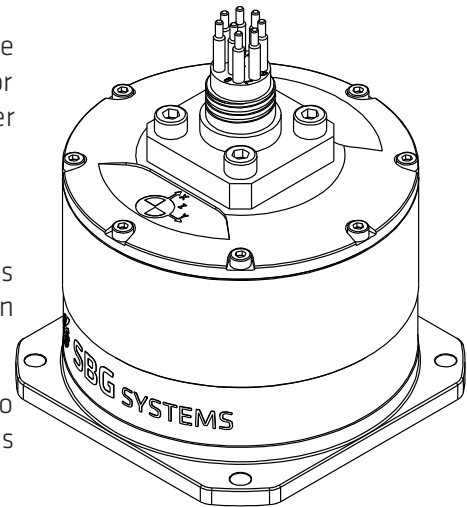

Figure 2.4: Ekinox Subsea IMU

2.2.2. Apogee IMU

Apogee IMU is considered as the highest accuracy for a MEMS Inertial measurement unit. This IMU is the unit of choice for challenging environments and benefits from its ultra low noise gyroscopes. Sensors specifications are listed below.

2.2.2.1. Accelerometers

	A3	Remarks
Full scale (g)	± 10	
Velocity Random Walk ($\mu\text{g}/\sqrt{\text{Hz}}$)	30	Allan variance – @ 25°C
In run bias instability (μg)	7	Allan variance – @ 25°C
Bandwidth (Hz)	100	Attenuation of 3 dB
Orthogonality (°)	< 0.02	Over temperature range

2.2.2.2. Gyroscopes

	G3	Remarks
Full scale (°/s)	± 200	
In run bias instability (°/hr)	0.05	Allan variance – @ 25°C
Angular Random Walk (°/√hr)	0.012	Allan variance – @ 25°C
Bandwidth (Hz)	100	Attenuation of 3 dB
Orthogonality (°)	0.02	Over temperature range

2.2.2.3. Surface form factor

The Apogee IMU enclosure is composed of two anodized aluminum parts (6061), one for the cover and one for the base plate. The device uses high quality alloys and connectors to offer a full IP-68 enclosure and a good resistance to harsh environments.

The Apogee IMU connector is a high quality push pull connector that offers IP-68 protection even unconnected.

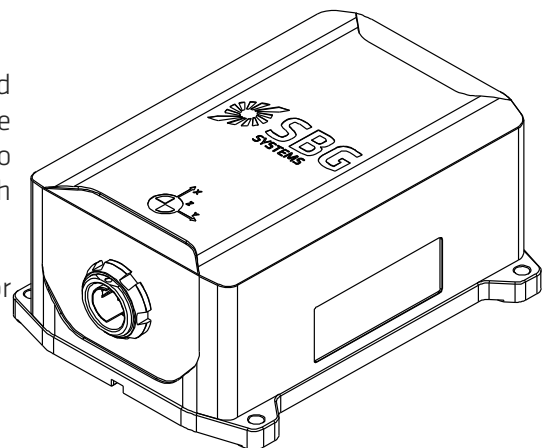

Figure 2.5: Apogee Surface IMU

Warning: The Apogee IMU surface model is not designed for prolonged operation in salt water environments. Check section Maintenance for more details about operation in sea water environments.

Mechanical alignment

For best measurement accuracy, a good mechanical alignment is required. During manufacturing, the Apogee IMU frame has been carefully aligned to 0.02° with the base plate for roll, pitch and yaw angles.

To ease the yaw alignment (X axis), the base plate features two alignment holes Ø 4 mm H8 that guarantees with two taper pins Ø 4 mm h7 a yaw alignment better than ±0.04°.

Origin of measurements

The Apogee IMU offers the possibility to output data at different measurement points.

The default center of measurement is located on top of Apogee enclosure, on the coordinate frame center drawing. It is represented on the mechanical outlines by the  symbol. This point is defined to simplify installation.

Alternatively, user can select between two other center of measurement points:

- Alignment hole (aligned to the bottom of the base plate)
- Bare IMU center of measurement, represented by the  symbol.

Specifications

The table below summarizes all mechanical and environmental specifications.

Electrical and Mechanical Specifications	
Enclosure materials	Anodized Aluminum (6061)
Dimensions	5.8 x 10.0 x 13 cm
Weight	635 g
Input power voltage	12 – 36 V DC – isolated power supply
Power consumption	2.5 W typical.
Environmental specifications	
IP rating	IP-68 (24 hours at 2 meters)
Humidity	Sealed, no limit
Operating Temperature range	-20°C to 60°C – specified range -40°C to 71°C – operating range
Storage Temperature range	-40°C to 85°C
Shocks	500 g for 0.3 ms
Operating Vibrations	1 g RMS – 20 Hz to 2 kHz as per MIL-STD-810G (A1 range) 8 g RMS – 20 Hz to 2 kHz as per MIL-STD-810G (A3 range)
MTBF	50 000 hours
Calibration interval	None required, maintenance free

2.2.2.4. Subsea form factor

The Apogee Subsea IMU enclosure is composed of titanium parts, one for the cover and one for the base plate. The device uses high quality connectors to offer a depth rating of 200 m and good resistance to seawater environment.

Mechanical alignment

For best measurement accuracy, a good mechanical alignment is required. During manufacturing, the Apogee IMU frame has been carefully aligned to 0.02° with the base plate for roll, pitch and yaw angles.

To ease the yaw alignment (X axis), the base plate features two alignment holes Ø 4 mm H8 that guarantees with two taper pins Ø 4 mm h7 a yaw alignment better than ±0.04°.

Origin of measurements

The Apogee IMU offers the possibility to output data at different measurement points.

The default center of measurement is located on top of Apogee enclosure, on the coordinate frame center drawing. It is represented on the mechanical outlines by the  symbol. It is defined to simplify installation.

Alternatively, user can select between two other center of measurement points:

- Alignment hole (aligned to the bottom of the base plate)
- Bare IMU center of measurement, represented by the  symbol.

Specifications

Electrical and Mechanical Specifications	
Enclosure materials	Titanium
Dimensions	Ø 9.2 x 17.75 cm
Weight in air	1.32 kg
Weight in water	0.98 kg
Input power voltage	12 – 36 V DC – isolated power supply
Power consumption	2.5 W typical.
Environmental specifications	
Depth rating	200 m
Humidity	Sealed, no limit
Operating Temperature range	-20°C to 60°C – specified range -40°C to 71°C – operating range
Storage Temperature range	-40°C to 85°C
Shocks	500 g for 0.3 ms
Operating Vibrations	3 g RMS – 20 Hz to 2 kHz as per MIL-STD-810G (A2 range options)
MTBF	50.000 hours
Calibration interval	None required, maintenance free

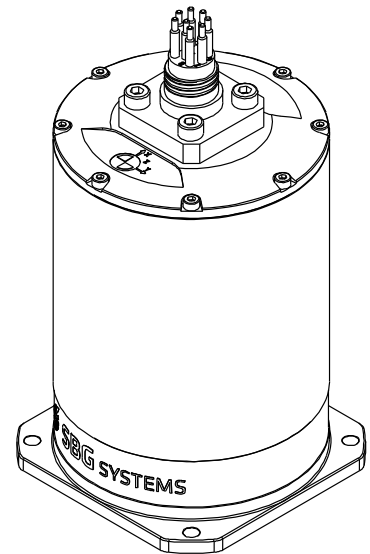

Figure 2.6: Apogee Subsea IMU

2.2.3. Horizon IMU

Horizon IMU is the highest performance available in Navsight Series. Leveraging on a closed loop Fiber Optic Gyroscopes technology, this IMU is the unit of choice for most difficult conditions such as high altitude survey / single antenna airborne applications, high depth survey, harsh automotive environments. The ultra low gyro bias enable optimal performance even in low dynamic conditions.

2.2.3.1. Accelerometers

	A3	Remarks
Full scale (g)	± 10	
Velocity Random Walk ($\mu\text{g}/\sqrt{\text{hz}}$)	100	Allan variance – @ 25°C
In run bias instability (μg)	100	Allan variance – @ 25°C
Orthogonality (°)	0.02	Over temperature range

2.2.3.2. Gyroscopes

	G3	Remarks
Full scale (°/s)	± 495	
In run bias instability (°/hr)	0.05	Allan variance – @ 25°C
Angular Random Walk (°/√hr)	0.012	Allan variance – @ 25°C
Orthogonality (°)	0.02	Over temperature range

2.2.3.3. Surface form factor

The Horizon IMU enclosure is composed of two anodized aluminum parts (6061), one for the cover and one for the base plate. The device uses high quality alloys and connectors to offer a full IP-68 enclosure and a good resistance to harsh environments.

The Horizon IMU connector is a high quality push pull connector that offers IP-68 protection even unconnected.

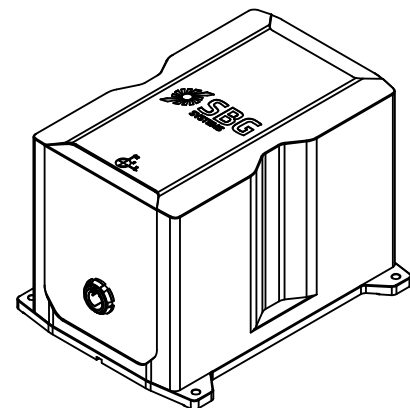

Figure 2.7: Horizon IMU

Warning: The Horizon IMU surface model is not designed for prolonged operation in salt water environments. Check section Maintenance for more details about operation in sea water environments.

Mechanical alignment

For best measurement accuracy, a good mechanical alignment is required. During manufacturing, the Horizon IMU frame has been carefully aligned to 0.02° with the base plate for roll, pitch and yaw angles.

To ease the yaw alignment (X axis), the base plate features two alignment holes Ø 4 mm H8 that guarantees with two taper pins Ø 4 mm h7 a yaw alignment better than ±0.04°.

Origin of measurements

The Horizon IMU offers the possibility to output data at different measurement points.

The default center of measurement is located on top of Horizon enclosure, on the coordinate frame center drawing. It is represented on the mechanical outlines by the  symbol. This point is defined to simplify installation.

Alternatively, user can select between two other center of measurement points:

- Alignment hole (aligned to the bottom of the base plate)
- Bare IMU center of measurement, represented by the  symbol.

2.2.4. Specifications

The table below summarizes all mechanical and environmental specifications.

Electrical and Mechanical Specifications	
Enclosure materials	Anodized Aluminum (6061)
Dimensions	15 x 16.8 x 21.5 cm
Weight	4.29 kg
Input power voltage	18 – 32 VDC
Power consumption	12 W typical
Environmental specifications	
Altitude rating	55 000 feet
IP rating	IP-67
Humidity	Sealed, no limit
Operating Temperature range	-20°C to 60°C – specified range -40°C to 71°C – operating range
Storage Temperature range	-40°C to 71°C
Shocks	6.0 g; 20 ms half-sine (operational) 40 g; 15 ms half-sine (non operational)
Operating Vibrations	4.1 g RMS – DO-160F, Cat. SC
Calibration interval	None required, maintenance free

2.3. Navsight Processing unit

The Navsight processing unit embeds all the processing power, an optional GNSS receiver and all the input and output interfaces.

2.3.1. Rugged packaging

Thanks to a robust IP-67 design the Rugged Processing unit is perfectly suited for most applications. An anodized aluminum enclosure (6061) ensures proper protection against harsh environments.

Located on the front panel, a membrane keyboard and LED indicators inform user about system health.

On the back face, robust connectors are integrated. Check out section Processing unit Interfaces specifications for more details about processing unit connectors and interfaces.



Figure 2.8: Rugged processing unit front face

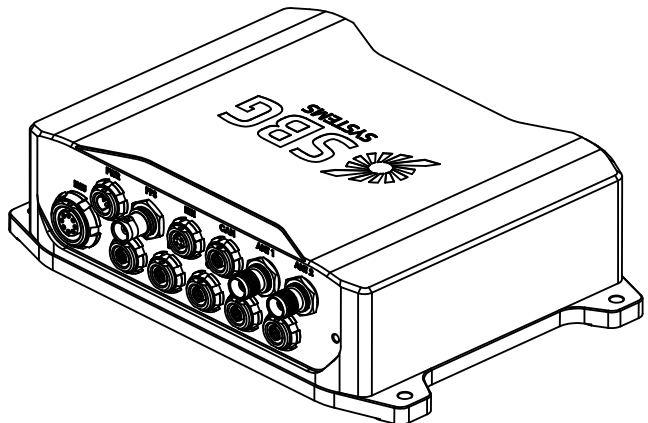

Figure 2.9: Rugged processing unit back face

2.3.1.1. Mechanical specifications

The table below summarizes all mechanical and environmental specifications.

Electrical and Mechanical Specifications	
Enclosure materials	Anodized Aluminum (6061)
Dimensions	23.3 x 15.6 x 6.3 cm
Weight	1.94 kg
Input power voltage	12 – 36 V DC – isolated power supply External international AC/DC converter
Power consumption (excl. IMU)	E: 7.5 W S: 8.5 W
Environmental specifications	
IP rating	IP-67
Humidity	Sealed, no limit
Operating Temperature range	-40°C to 71°C
Storage Temperature range	-40°C to 85°C
Operating Vibrations	6 g RMS – 20 Hz to 2 kHz as per MIL-STD-810G

2.3.2. Rack packaging

The rack version of Navsight processing unit is well suited for integration into a standard 19” rack setup. In addition, the use of standard connectors such as RJ-45 and DB-9 enable fast integration.

Located on the front panel, a membrane keyboard and LED indicators inform user about system health.

On the back face, all connectors are integrated. Check out section Processing unit Interfaces specifications for more details about processing unit connectors and interfaces.

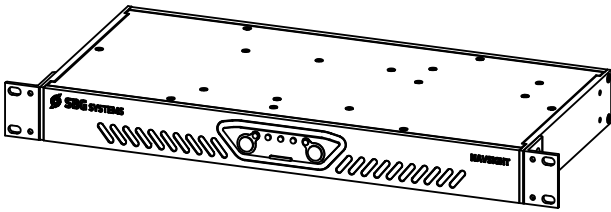

Figure 2.10: Rack processing unit front face

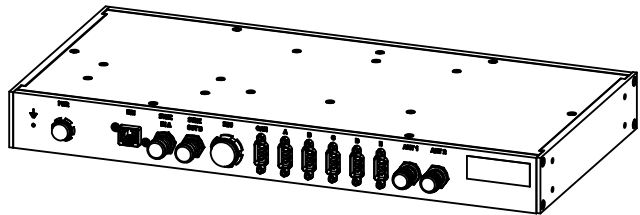

Figure 2.11: Rack processing unit back face

2.3.2.1. Mechanical specifications

The table below summarizes all mechanical and environmental specifications.

Electrical and Mechanical Specifications	
Enclosure materials	Aluminum (painted)
Dimensions	42.2 x 20.4 x 4.4 cm (standard 1U 19” rack)
Weight	1.99 kg
Input power voltage	12 - 36 V DC – isolated power supply External international AC/DC converter
Power consumption	E: 7.5 W S: 8.5 W
Environmental specifications	
Operating Temperature range	-40°C to 71°C
Storage Temperature range	-40°C to 85°C
Operating Vibrations	6 g RMS – 20 Hz to 2 kHz as per MIL-STD-810G

2.3.3. Internal GNSS (Septentrio Asterx-4, HW Revision <= 2.1)

The NAVSIGHT-S embed a very high end, survey grade, dual antenna, Septentrio AsterX-4 GNSS receiver that is perfectly fitted for the very demanding survey market.

It features L1/L2/L5 and L-Band signals tracking and uses GPS, GLONASS, BEIDOU and GALILEO constellations to provide very accurate and reliable measurements even in harsh environments.

The internal dual L-Band demodulator supports Fugro Marinestar™ PPP services to delivery world wide, with no specific infrastructure, a positioning accuracy better than 10 cm.

This latest generation GNSS receiver also features very accurate RTK positioning with the world's leading signal availability and minimal re-acquisition time after a GNSS outage. This receiver provides best accuracy and reliability in harsh GNSS environments thanks to a very advanced auto mitigating algorithm that detects and eliminates multi-path situations or Inmarsat / Iridium jamming.

	Specification		Remark
Channels	448		
Signal tracking	GPS: L1, L2, L2C, L5 GLONASS: L1, L2, L2CA Galileo: E1, E5ab, E6	Beidou B1, B2, B3 SBAS, QZSS	
Horizontal position accuracy	Single point L1/L2/L5	1.0 m	PPP support requires a valid subscription from a third party PPP service provider.
	SBAS / DGPS	0.6 m / 0.4 m	
	PPP (Marinestar™)	10 cm	
	RTK	0.6 cm + 0.5 ppm	
Velocity accuracy	3 cm/s RMS		
True Heading Accuracy	0.2 °	1 m baseline	GNSS only true heading accuracy, not enhanced by the INS.
	0.1 °	2 m baseline	
	0.05 °	4 m baseline	
Operating Limits	Velocity: 515 m/s * Acceleration: 10 g	*Due to export control	
Time to First Fix	Cold start	< 45 s	
	Hot start	< 15 s	
Signal reacquisition	L1/L2/L5	< 1.0 s	
Output frequency	PVT: 5 Hz (Max 20 Hz) RAW data: 1 Hz		
Diff. Corrections input	RTCM V2.2, V2.3, V3.0, V3.1 CMR 2.0, CMR+		

2.3.4. Internal GNSS (Septentrio Asterx-m3, HW Revision >= 2.1)

The latest revisions of NAVSIGHT-S embed a very high end, survey grade, dual antenna, Asterx-m3-fg Septentrio GNSS receiver that is perfectly fitted for the very demanding survey market.

It features L1/L2/L5 and L-Band signals tracking and uses GPS, GLONASS, BEIDOU and GALILEO constellations to provide very accurate and reliable measurements even in harsh environments.

The internal dual L-Band demodulator supports Fugro Marinestar™ PPP services to delivery world wide, with no specific infrastructure, a positioning accuracy better than 10 cm.

This latest generation GNSS receiver also features very accurate RTK positioning with the world's leading signal availability and minimal re-acquisition time after a GPS outage. This receiver provides best accuracy and reliability in harsh GNSS environments thanks to a very advanced auto mitigating algorithm that detects and eliminates multi-path situations or Inmarsat / Iridium jamming.

	Specification	Remark	
Channels	544		
Signal tracking	GPS: L1 C/1, L2, L2C, L5 GLONASS: L1 C/A, L2 C/A, L2P, L3 GALILEO: E1, E5a, E5b Beidou: B1I, B1C, B2a, B2I, B3I	QZSS: L1 C/A, L2C, L5 SBAS integrated L-band	All constellations & signals enabled by default
Horizontal position accuracy	Single Point L1/L2/L5 SBAS / DGNSS RTK PPP (MARINESTAR™)	1.2 m 0.6 m / 0.4 m 0.6 cm + 0.5 ppm 10 cm	RTK enabled by default PPP support requires a valid subscription from a third party PPP service provider.
Velocity Accuracy	0.03 m/s RMS		
True Heading Accuracy	0.15° 0.03°	1 m baseline 5 m baseline	
Velocity limit	515 m/s	Due to export licenses	
Time to First Fix	Cold start Hot start	< 45 s < 20 s	
Signal reacquisition	L1/L2/L5	< 1 s	
Output frequency	PVT: 5 Hz (Max 20 Hz) RAW data: 1 Hz (Max 100 Hz)		
Diff. Corrections	RTCM V2.x, V3.x CMR V2.0, CMR+		

2.3.5. Internal GNSS (Trimble, HW revision ≥ 1.5 and ≤ 2.1)

The NAVSIGHT-T embed a high end, survey grade, dual antenna, Trimble GNSS receiver that is perfectly fitted for the very demanding survey market.

It features L1/L2/L5 and L-Band signals tracking and uses GPS, GLONASS, BEIDOU and GALILEO constellations to provide very accurate and reliable measurements even in harsh environments.

The internal L-Band demodulator supports OmniSTAR and Marinestar™ Precise Point Positioning (PPP) services to delivery world wide, with no specific infrastructure, a positioning accuracy better than 10 cm.

This high performance GNSS receiver also features very accurate RTK positioning. This receiver provides excellent accuracy and reliability in harsh GNSS environments.

	Specification		Remark
Channels	336		
Signal tracking	GPS: L1 C/A, L2E, L2C, L5 GLONASS: L1 C/A, L2 C/A, L3 CDMA Galileo: E1, E5A, E5B, E5AltBOC, E6	Beidou B1, B2, B3 SBAS, QZSS L1 C/A, L2C, L5 L-Band OmniSTAR, RTX	
Horizontal position accuracy (1 sigma)	SBAS / DGPS PPP RTK	0.5 m / 0.25 m 10 cm 0.8 cm + 1 ppm	PPP support requires a valid subscription from a third party PPP service provider. RTK positioning mode available in option
Velocity accuracy	0.7 cm/s RMS		
True Heading Accuracy	0.09 ° 0.05 °	2 m baseline 10 m baseline	GNSS only true heading accuracy, not enhanced by the INS.
Operating Limits	Altitude: 18 000m * Velocity: 515 m/s * Acceleration: 11 g		*Due to export control
Time to First Fix	Cold start Warm start	< 45 s < 30 s	
Signal reacquisition	L1/L2/L5	< 2.0 s	
Output frequency	PVT: 5 Hz Raw data: 1 Hz		
Diff. Corrections input	RTCM V2.1 V2.2, V2.3, V3.0, V3.1 CMR, CMR+, SCMRX		

2.3.6. Internal GNSS (Trimble, HW revision < 1.5)

The NAVSIGHT-T embed a high end, survey grade, dual antenna, Trimble GNSS receiver that is perfectly fitted for the very demanding survey market.

It features L1/L2/L5 and L-Band signals tracking and uses GPS, GLONASS, BEIDOU and GALILEO constellations to provide very accurate and reliable measurements even in harsh environments.

The internal L-Band demodulator supports OmniSTAR and Marinestar™ Precise Point Positioning (PPP) services to delivery world wide, with no specific infrastructure, a positioning accuracy better than 10 cm.

This high performance GNSS receiver also features very accurate RTK positioning. This receiver provides excellent accuracy and reliability in harsh GNSS environments.

	Specification	Remark
Channels	220	
Signal tracking	GPS: L1 C/A, L2E, L2C, L5 GLONASS: L1 C/A, L2 C/A, L2 P, L3 CDMA Galileo: E1 BOC, E5A, E5B, E5AltBOC Beidou B1, B2 SBAS, QZSS L-Band OmniSTAR VBS, HP, XP	
Horizontal position accuracy (1 sigma)	SBAS / DGPS 0.5 m / 0.25 m PPP 10 cm RTK 0.8 cm + 1 ppm	PPP support requires a valid subscription from a third party PPP service provider. RTK positioning mode available in option
Velocity accuracy	0.7 cm/s RMS	
True Heading Accuracy	0.09 ° 0.05 °	2 m baseline 10 m baseline GNSS only true heading accuracy, not enhanced by the INS.
Operating Limits	Altitude: 18 000m * Velocity: 515 m/s * Acceleration: 11 g	*Due to export control
Time to First Fix	Cold start < 45 s Warm start < 30 s	
Signal reacquisition	L1/L2/L5 < 2.0 s	
Output frequency	PVT: 5 Hz Raw data: 1 Hz	
Diff. Corrections input	RTCM V2.1 V2.2, V2.3, V3.0, V3.1 CMR, CMR+, SCMRX	

3. System Performance specification

All specifications are rated to 1σ , over -40°C to $+75^{\circ}\text{C}$ unless otherwise stated.

These specifications have been obtained by field tests, using typical mission scenarios and comparison to reference units using post-processing. Outage performance validated by simulation of repeated, pure GNSS outages, separated by at least 200 s of optimal GNSS condition, compared to a reference RTK trajectory.

They refer to latest hardware revision with latest stable firmware version.

Performance parameters may be affected in multi-path and poor GNSS reception environments such as Urban canyons.

For each application, we present the specified accuracy for the following positioning modes:

- **SP:** Single Point mode and is the default L1 GNSS fix quality
- **RTK:** Real Time Kinematics with a typical 1 cm accuracy position
- **PP:** Post Processed data using Qinertia with at least Precise Point Positioning data

3.1. Ekinox grade performance specifications

3.1.1. Common specifications

	Performance	Remarks
Measurement range	360° in all axes, no mounting limitation	Solid state sensors
Orientation noise	< 0.02° RMS	Static

3.1.2. Land applications

All specifications are valid with DMI (odometer) aiding for typical land mapping trajectories.

Outage Duration	Positioning Mode	Position Accuracy (m)		Velocity Accuracy (m/s)		Attitude Accuracy (°)	
		Horizontal	Vertical	Horizontal	Vertical	Roll / Pitch	Heading
0 s	SP	1.20 m	1.20 m	0.05 m/s	0.05 m/s	0.02°	0.05°
	RTK	0.01 m + 0.5 ppm	0.015 m + 1 ppm	0.02 m/s	0.02 m/s	0.015°	0.04°
	PP	0.01 m + 0.5 ppm	0.015 m + 1 ppm	0.01 m/s	0.01 m/s	0.01°	0.03°
10 s	SP	1.5 m	1.4 m	0.05 m/s	0.05 m/s	0.03°	0.06°
	RTK	0.15 m	0.1 m	0.03 m/s	0.03 m/s	0.02°	0.05°
	PP	0.03 m	0.03 m	0.015 m/s	0.01 m/s	0.015°	0.03°
60 s / 1 km	SP	4 m	2.5 m	0.1 m/s	0.1 m/s	0.08°	0.15°
	RTK	3 m	0.75 m	0.1 m/s	0.1 m/s	0.08°	0.12°
	PP	0.4 m	0.1 m	0.03 m/s	0.02 m/s	0.04°	0.05°

3.1.3. Marine & Subsea applications

All specifications are valid with dual antenna aiding for typical marine survey trajectories.

Outage Duration	Positioning Mode	Position Accuracy (m)		Velocity Accuracy (m/s)		Attitude Accuracy (°)	
		Horizontal	Vertical	Horizontal	Vertical	Roll / Pitch	Heading
0 s	SP	1.20 m	2.0 m	0.05 m/s	0.05 m/s	0.02°	0.03° (baseline > 2 m)
	RTK	0.01 m + 0.5 ppm	0.015 m + 1 ppm	0.02 m/s	0.02 m/s	0.015°	0.02° (baseline > 4 m)
	PP	0.01 m + 0.5 ppm	0.015 m + 1 ppm	0.01 m/s	0.01 m/s	0.01°	0.02°
10 s	SP	2.2 m	2.5 m	0.1 m/s	0.05 m/s	0.03°	0.05° (baseline > 2 m)
	RTK	0.3 m	0.1 m	0.05 m/s	0.03 m/s	0.02°	0.04° (baseline > 4 m)
	PP	0.05 m	0.03 m	0.02 m/s	0.01 m/s	0.015°	0.02°
30 s	SP	4.0 m	2.5 m	0.3 m/s	0.15 m/s	0.05°	0.12° (baseline > 2 m)
	RTK	3.0 m	0.75 m	0.25 m/s	0.1 m/s	0.05°	0.1° (baseline > 4 m)
	PP	1.0 m	0.3 m	0.05 m/s	0.03 m/s	0.04°	0.05°

3.1.3.1. Heave performance

	Real Time Heave	Delayed Heave (ShipMotionHP)	Remark
Range	50 meters	50 meters	Automatic adjustment to every sea conditions
Period	0 to 20 s	0 to 40 s	
Accuracy	5 cm or 5 %	2 cm or 2.5 %	Whichever is greater; Velocity aided heave
Mode	Real time, auto tuning	Fixed 150 s delay	On board computation

3.1.4. Airborne applications

Specifications evaluated with a dual antenna heading source.

Positioning Mode	Position Accuracy (m)		Velocity Accuracy (m/s)		Attitude Accuracy (°)	
	Horizontal	Vertical	Horizontal	Vertical	Roll / Pitch	Heading
SP	1.20 m	2.0 m	0.05 m/s	0.05 m/s	0.02°	0.03° (baseline > 2 m)
RTK	0.01 m + 0.5 ppm	0.015 m + 1 ppm	0.02 m/s	0.02 m/s	0.015°	0.02° (baseline > 4 m)
PP	0.01 m + 0.5 ppm	0.015 m + 1 ppm	0.01 m/s	0.01 m/s	0.01°	0.02°

3.2. Apogee grade specifications

3.2.1. Common specifications

	Performance	Remarks
Measurement range	360° in all axes, no mounting limitation	Solid state sensors
Orientation noise	< 0.002° RMS	Static conditions

3.2.2. Marine & Subsea applications

All specifications are valid with dual antenna aiding for typical marine survey trajectories.

Outage Duration	Positioning Mode	Position Accuracy (m)		Velocity Accuracy (m/s)		Attitude Accuracy (°)	
		Horizontal	Vertical	Horizontal	Vertical	Roll / Pitch	Heading
0 s	SP	1.0 m	1.0 m	0.02 m/s	0.01 m/s	0.01°	0.02° (baseline > 2 m)
	RTK	0.01 m + 0.5 ppm	0.015 m + 1 ppm	0.01 m/s	0.01 m/s	0.008°	0.01° (baseline > 4 m)
	PPK	0.01 m + 0.5 ppm	0.015 m + 1 ppm	0.01 m/s	0.01 m/s	0.005°	0.01°
10 s	SP	1.20 m	1.10 m	0.03 m/s	0.015 m/s	0.01°	0.03° (baseline > 2 m)
	RTK	0.17 m	0.10 m	0.02 m/s	0.015 m/s	0.008°	0.02° (baseline > 4 m)
	PPK	0.03 m	0.02 m	0.015 m/s	0.01 m/s	0.005°	0.015°
60 s	SP	5.0 m	2.0 m	0.15 m/s	0.075 m/s	0.015°	0.05° (baseline > 2 m)
	RTK	4.0 m	0.75 m	0.15 m/s	0.075 m/s	0.012°	0.04° (baseline > 4 m)
	PPK	0.15 m	0.05 m	0.04 m/s	0.03 m/s	0.008°	0.025°

3.2.2.1. Heave performance

	Real Time Heave	Delayed Heave (ShipMotionHP)	Remark
Range	50 meters	50 meters	Automatic adjustment to every sea conditions
Period	0 to 20 s	0 to 40 s	
Accuracy	5 cm or 5%	2 cm or 2 %	Whichever is greater; Velocity aided heave
Mode	Real time, auto tuning	Fixed 150 s delay	On board computation

3.2.3. Land applications

All specifications are valid with DMI (odometer) aiding for typical land mapping trajectories.

Outage Duration	Positioning Mode	Position Accuracy (m)		Velocity Accuracy (m/s)		Attitude Accuracy (°)	
		Horizontal	Vertical	Horizontal	Vertical	Roll / Pitch	Heading
No Outage	SP	1.0 m	1.0 m	0.02 m/s	0.01 m/s	0.01°	0.03°
	RTK	0.01 m + 0.5 ppm	0.015 m + 1 ppm	0.01 m/s	0.01 m/s	0.008°	0.02°
	PPK	0.01 m + 0.5 ppm	0.015 m + 1 ppm	0.01 m/s	0.01 m/s	0.005°	0.01°
10 s	SP	1.1 m	1.0 m	0.03 m/s	0.02 m/s	0.01°	0.04°
	RTK	0.05 m	0.05 m	0.02 m/s	0.02 m/s	0.008°	0.03°
	PPK	0.02 m	0.02 m	0.015 m/s	0.01 m/s	0.005°	0.015°
60 s / 1 km	SP	1.5 m	1.3 m	0.03 m/s	0.02 m/s	0.015°	0.06°
	RTK	0.5 m	0.3 m	0.02 m/s	0.02 m/s	0.012°	0.06°
	PPK	0.1 m	0.05 m	0.02 m/s	0.015 m/s	0.008°	0.025°

3.2.4. Airborne applications

All specifications are valid with dual antenna aiding for typical aerial survey trajectories.

Positioning Mode	Position Accuracy (m)		Velocity Accuracy (m/s)		Attitude Accuracy (°)	
	Horizontal	Vertical	Horizontal	Vertical	Roll / Pitch	Heading
SP	1.0 m	1.0 m	0.02 m/s	0.01 m/s	0.01°	0.02° (baseline > 2 m)
RTK	0.01 m + 0.5 ppm	0.015 m + 1 ppm	0.01 m/s	0.01 m/s	0.008°	0.01° (baseline > 4 m)
PPK	0.01 m + 0.5 ppm	0.015 m + 1 ppm	0.01 m/s	0.01 m/s	0.005°	0.01°

3.3. Horizon grade specifications

3.3.1. Marine applications

All specifications are valid with dual antenna aiding for typical marine survey trajectories.

Outage Duration	Positioning Mode	Position Accuracy (m)		Velocity Accuracy (m/s)		Attitude Accuracy (°)	
		Horizontal	Vertical	Horizontal	Vertical	Roll / Pitch	Heading
0 s	SP	1.0 m	1.0 m	0.01 m/s	0.01 m/s	0.007°	0.01° (baseline > 2 m)
	RTK	0.01 m + 0.5 ppm	0.01 m + 1 ppm	0.01 m/s	0.01 m/s	0.007°	
	PPK	0.01 m + 0.5 ppm	0.01 m + 1 ppm	0.01 m/s	0.01 m/s	0.004°	0.008°
10 s	SP	1.1 m	1.05 m	0.015 m/s	0.015 m/s	0.007°	0.01° (baseline > 2 m)
	RTK	0.1 m	0.1 m	0.015 m/s	0.015 m/s	0.007°	
	PPK	0.01 m	0.02 m	0.01 m/s	0.01 m/s	0.004°	0.01°
60 s	SP	2.0 m	2.0 m	0.035 m/s	0.025 m/s	0.01°	0.015° (baseline > 2 m)
	RTK	1.0 m	0.5 m	0.035 m/s	0.025 m/s	0.01°	
	PPK	0.10 m	0.05 m	0.03 m/s	0.01 m/s	0.005°	0.01°

3.3.1.1. Heave performance

	Real Time Heave	Delayed Heave (ShipMotionHP)	Remark
Range	50 meters	50 meters	Automatic adjustment to every sea conditions
Period	0 to 20 s	0 to 40 s	
Accuracy	5 cm or 5 %	2 cm or 2 %	Whichever is greater; Velocity aided heave
Mode	Real time, auto tuning	Fixed 150 s delay	On board computation

3.3.2. Land applications

All specifications are valid with DMI (odometer) aiding for typical land mapping trajectories.

Outage Duration	Positioning Mode	Position Accuracy (m)		Velocity Accuracy (m/s)		Attitude Accuracy (°)	
		Horizontal	Vertical	Horizontal	Vertical	Roll / Pitch	Heading
No Outage	SP	1.0 m	1.0 m	0.01 m/s	0.01 m/s	0.007°	0.01°
	RTK	0.01 m + 0.5 ppm	0.01 m + 1 ppm	0.01 m/s	0.01 m/s	0.007°	0.01°
	PPK	0.01 m + 0.5 ppm	0.01 m + 1 ppm	0.01 m/s	0.01 m/s	0.004°	0.008°
10 s	SP	1.1 m	1.05 m	0.015 m/s	0.015 m/s	0.007°	0.01°
	RTK	0.07 m	0.07 m	0.015 m/s	0.015 m/s	0.007°	0.01°
	PPK	0.01 m	0.02 m	0.01 m/s	0.01 m/s	0.004°	0.008°
60 s / 1 km	SP	2.0 m	2.0 m	0.035 m/s	0.025 m/s	0.01°	0.015°
	RTK	0.75 m	0.5 m	0.035 m/s	0.025 m/s	0.01°	0.015°
	PPK	0.05 m	0.03 m	0.03 m/s	0.01 m/s	0.005°	0.01°

3.3.3. Airborne applications

All specifications are valid with dual antenna aiding for typical aerial survey trajectories.

Outage Duration	Positioning Mode	Position Accuracy (m)		Velocity Accuracy (m/s)		Attitude Accuracy (°)	
		Horizontal	Vertical	Horizontal	Vertical	Roll / Pitch	Heading
No Outage	SP	1.0 m	1.0 m	0.01 m/s	0.01 m/s	0.007°	0.04° (Single antenna)
	RTK	0.01 m	0.02 m	0.01 m/s	0.01 m/s	0.007°	0.01° (>4 m Dual ant.)
	PPK	0.01 m	0.02 m	0.01 m/s	0.01 m/s	0.004°	0.008°
10 s	SP	1.1 m	1.05 m	0.015 m/s	0.015 m/s	0.007°	0.04° (Single antenna)
	RTK	0.1 m	0.1 m	0.015 m/s	0.015 m/s	0.007°	0.01° (>4 m Dual ant.)
	PPK	0.01 m	0.02 m	0.01 m/s	0.01 m/s	0.004°	0.008°
60s	SP	2.0 m	2.0 m	0.35 m/s	0.025 m/s	0.01°	0.05° (Single antenna)
	RTK	1.0 m	0.5 m	0.35 m/s	0.025 m/s	0.01°	0.015° (>4 m Dual ant.)
	PPK	0.15 m	0.1 m	0.03 m/s	0.01 m/s	0.005°	0.01°

4. IMU interface specification

The link between IMU and processing unit uses a set of RS-485 half duplex communication and RS-422 synchronization interfaces that is suitable for secured, long distance communication.

4.1. Surface IMU interfaces

All surface IMU models use the same circular, push-pull connector (ODU G83F1C-P08RP09-0000).

The connector pin-out is the following

Pin #	Name	Description
1	SYNC+	RS-422 Sync output +
2	SYNC-	RS-422 Sync output -
3	VCC	Input power supply voltage
4	PGND	Power Supply Return
5	SHIELD	Cable SHIELD / Chassis Ground
6	SGND	Signal ground (Sync and Data)
7	IMU Data A	Positive RS-485 data input/output
8	IMU Data B	Negative RS-485 data input/output

The surface IMU connectors mate with the ODU connector ref: S33F1C-P08LPH90200.

4.2. Subsea IMU interfaces

All Subsea IMU models use the same sea water proof connector (McArtney Subconn FCR1508MTI).

The connector pin-out is the following:

Pin #	Name	Description
1	VCC	Input power supply voltage
2	PGND	Power Supply Return
3	SHIELD	Cable SHIELD
4	SGND	Signal ground (Sync and Data)
5	IMU Data A	Positive RS-485 data input/output
6	IMU Data B	Negative RS-485 data input/output
7	SYNC+	RS-422 Sync output +
8	SYNC-	RS-422 Sync output -

The subsea connector mates with Subconn Micro Circular MCIL8FNM plug.



Note: the subsea connector is made in Chloroprene rubber. The cable plug needs to be regularly greased with a silicon compound such as Molykote 44 medium. Failing to do so can lead to the fusion of connector plug and receptacle.

5. Processing unit Interfaces specifications

5.1. Rugged version Overview

Following diagrams show the different interfaces available on a Navsight processing unit. Front face is dedicated to quick user access to main functions and status indication.

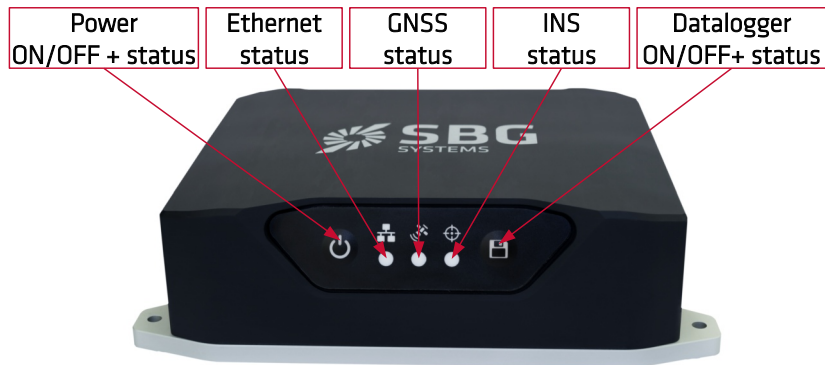

Figure 5.1: Navsight Rugged Processing unit front face user interface

The back face of Navsight processing unit is used to hold all electrical connections. A single connector is generally dedicated to a single interface to enable easy connections on various systems. A specific keying or connector type ensures that there will be no mis-connection (eg. Ethernet cable cannot be connected on a serial port interface).

All connectors that are not always used are dust protected with appropriate caps.

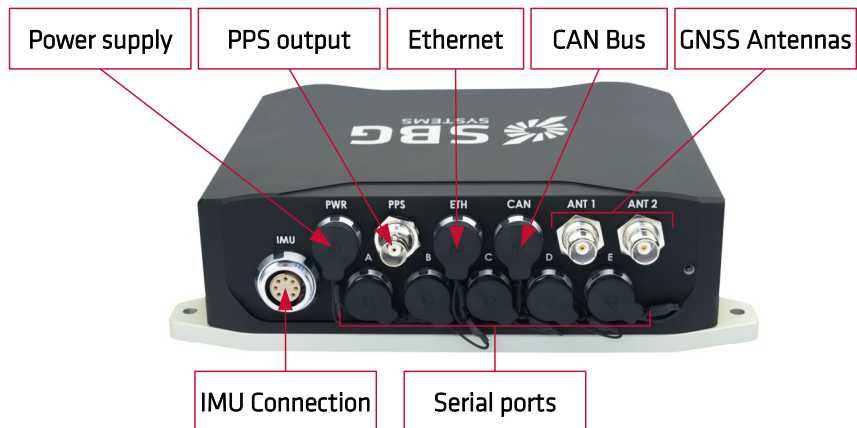

Figure 5.2: Navsight rugged processing unit back face interfaces

5.2. Rack version Overview

The rack version of Navsight present the same interfaces and capabilities as the rugged one. Following diagrams show the different interfaces available on a Navsight processing unit. Front face is dedicated to quick user access to main functions and status indication.



Figure 5.3: Navsight Rack Processing unit front face user interface

The back face of Navsight processing unit is used to hold all electrical connections. A single connector is generally dedicated to a single interface to enable easy connections on various systems. Standard connectors enable easy connection with the third party systems.

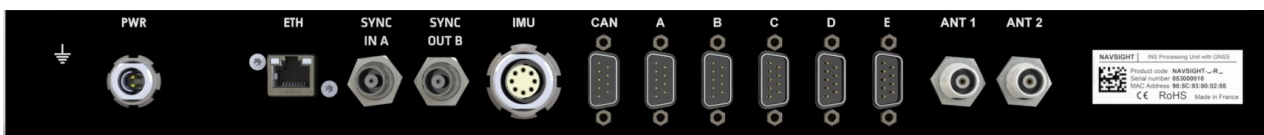

Figure 5.4: Navsight rack processing unit back face interfaces

5.3. Interfacing capabilities

The Navsight processing unit includes a wide range of interfaces:

- 1 x IMU interface, dedicated to secure IMU data input over long distance.
- 1 x RS-232 and 4 x RS-232/422 serial interfaces (PORT A, B, C, D and E) that can be used to input aiding information, output navigation data, or configure the system
- 1 x Ethernet interface with various services
 - Web page for configuration and real time visualization purpose
 - Access to internal GNSS web page and associated services
 - 5 x UDP / TCP/IP interfaces that can be used as additional bidirectional communication interfaces
 - FTP server for datalogger access
- Internal datalogger with 8 GB storage capacity
- 1 x CAN bus interface for data output
- 5 x Synchronization inputs that can be used for event input, external aiding time-stamping or PPS input
- 2 x Synchronization outputs that can be used for PPS output or data time-stamping.

The following table details for each serial interface the associated capabilities.

	Port A	Port B	Port C	Port D	Port E	Eth 0	Eth 1-4
Binary commands	●					●	
External GNSS input	●	●	●	●	●	●	●
Odometer input					●		
RTCM input	●	●	●	●	●	●	●
DVL input	●	●	●	●	●		●
Data output	●	●	●	●	●	●	●

 Maximum supported odometer pulse rate is 10 kHz

5.3.1. Supported protocols





Navsight solution has been designed to be connected to a large range of aiding equipment. In addition to the native sbgECom binary protocol, other third party or standard protocols are also supported such as NMEA, RTCM, TSS1, Septentrio SBF, Novatel Binary protocol, Trimble and others.

 **Note:** For a complete description of the sbgECom and other supported protocols, please refer to the SBG Systems Firmware Reference Manual.

5.4. Keyboard and LEDs indicators

5.4.1. LEDs status indicators



Following LEDs display various useful status information.

LED	Name	Color codes
	Power status	OFF: No power supply available RED: Unit is Idle (not running but power is available). BLINKING ORANGE: No valid IMU data has been received BLINKING GREEN: Unit is starting up and is not yet ready GREEN: Unit is running correctly
	Ethernet status	OFF: No network connected RED: The product wasn't able to get a valid auto ip (private) or static IP address ORANGE: The product has a valid auto ip (private) or static IP address GREEN: The product has successfully obtained a valid IP address from a DHCP server
	GNSS status	OFF: No GNSS available BLINKING RED: Unknown positioning mode RED: Standalone mode BLINKING ORANGE: DGNSS with RTCM data older than 10 seconds ORANGE: Stable DGNSS mode with optimal RTCM age BLINKING GREEN: Float RTK or PPP solution GREEN: Fixed RTK or PPP solution (centimetric accuracy)
	INS status	OFF: Kalman filter is not yet initialized BLINKING RED: Vertical gyro / AHRs mode in alignment phase RED: Vertical gyro / AHRs in aligned mode BLINKING ORANGE: INS, in alignment phase. INS outputs are not all in "valid state" ORANGE: INS is aligned but Position/Velocity/Attitude/Heading are not all in "valid state" BLINKING GREEN: INS, in alignment mode. INS outputs are all in "valid state" GREEN: INS, is aligned and Position/Velocity/Attitude/Heading are all in "valid state"
	Datalogger status	OFF: Datalogger not running RED: Datalogger error or full BLINKING RED: Data logger disk is being formatted BLINKING ORANGE: Data logger is waiting for data but disk is almost full > 80% ORANGE: Data logger is logging but almost full >80% BLINKING GREEN: Data logger is waiting for data GREEN: Data logger is running



5.4.2. Buttons actions

In addition to checking the system status, it is also possible to use the keypad buttons in order to perform several useful actions. Basic actions will be typically performed at every mission while the advanced actions should be used for troubleshooting purpose.

5.4.2.1. Basic actions

Action	
Power ON/OFF	Press the  button (short press). The corresponding LED should be GREEN when running or RED when Idle.
Start/Stop Datalogger	Press the  button (short press). The corresponding LED should be GREEN when running and OFF when datalogger is disabled.

5.4.2.2. Advanced actions

Action	
System Reboot	Press and hold the  button for more than 5 s.
Reset device settings	In case you cannot communicate with the unit anymore (unknown Ethernet settings for instance), it is possible to restore default settings by pressing and holding  and  buttons together longer than 5 s.

5.5. IMU interface

The IMU interface is required to connect an external IMU to the processing unit. Both rugged processing unit and rack processing unit use the same IMU receptacle (ODU ref G83F1C-P08LPH9-0000).

The IMU connector mates with the plug ref S43F1C-P08MPH9-020S.

Connector's pin-out is the following:

Pin #	Name	Description
1	SYNC+	IMU Sync input +
2	SYNC-	IMU Sync input -
3	VCC	Input power supply voltage
4	PGND	Power supply return
5	SHIELD	SHIELD / Chassis Ground
6	SGND	Signal ground (Sync and Data)
7	IMU Data A	Positive RS-485 data input/output
8	IMU Data B	Negative RS-485 data input/output

5.6. ETH interface

The Navsight processing unit port features an Ethernet 100BASE-T interface. This interface is used for the device installation and configuration through an embedded web page.

This Ethernet interface is a key feature of the Navsight solution as it provides the following services:

- A Bonjour service used to easily discover any connected SBG Systems device and get its IP address
- An embedded web interface used to configure the device and visualize output data
- An FTP access to download logs recorded in the internal Flash memory
- Five virtual serial ports Eth0 to Eth4 that support either UDP or TCP/IP protocols

5.6.1. Accessing the Navsight web page

Thanks to the ZeroConf technology, you can easily access the web page using the Navsight serial number. Indeed, the Navsight broadcast a web service so you can connect to the configuration web page using the following address:

http://navsight_020000001.local

Where 020000001 is the device serial number. It can be found on a label located on the enclosure's right side.

If your web browser supports DNS Service Discovery such as Safari, you should directly see a link to all SBG Systems devices available on the network.



Browser Compatibility: SBG Systems recommend using latest version of Chrome, Safari, Firefox or Edge web browsers. Due to Internet Explorer limitations, only versions 10 and above are supported.

5.6.2. Connector specifications (rugged)

The Ethernet connector uses a 4 ways female ODU connector (ref G81F1C-P04LJG00000). The connector mates with plug ref S31F1C-P04MJG0-5500. Other manufacturers such as Fischer provide compatible plugs (Fischer Core Series)

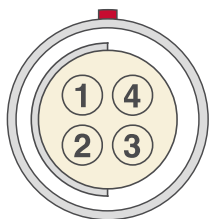

Figure 5.6: Main receptacle, front view



Figure 5.5: Main plug

Connector's pin-out is the following:

Pin #	Name	Description
SHIELD	SHIELD	Connected to the mechanical ground
1	TX+	Ethernet Tx+
2	TX-	Ethernet Tx-
3	RX+	Ethernet Rx+
4	RX-	Ethernet Rx-

5.6.3. Connector specifications (rack)

The Ethernet interface uses a standard RJ-45 connector for direct interfacing on the network.

5.7. CAN interface

Navsight includes a CAN 2.0 A/B interface that supports transfer rate at up to 1 Mbits/s. At the time of writing this document, this CAN interface is only used to output log messages. By default, the CAN interface is disabled.

The CAN bus implementation and especially timing settings complies with the CAN in Automation (CiA) DS-102 standard.

Navsight CAN interface supports the following standard bitrates:

- 1 000 kBit/s
- 500 kBit/s
- 250 kBit/s
- 125 kBit/s
- 100 kBit/s
- 50 kBit/s
- 20 kBit/s
- 10 kBit/s



Note: Navsight does not include any termination resistor, and it belongs to user to ensure that the CAN bus includes termination resistors in order to get proper communications.

5.7.1. Connector specifications (rugged)

The CAN connector uses an 8 ways female ODU connector (ref G81F1C-P08LFG00000). Other manufacturers such as Fischer provide compatible plugs (Fischer Core Series). The connector mates with plug ref S31F1C-P08MFG0-5500.

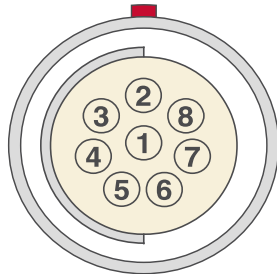

Figure 5.7: Receptacle front panel view



Figure 5.8: External plug

Connector's pin-out is the following:

Pin #	Name	Description
SHIELD	SHIELD	Connected to the mechanical ground
1	NC	Not internally connected
2	NC	Not internally connected
3	CAN H	CAN High
4	GND	Signal Ground
5	CAN L	CAN Low
6	NC	Not internally connected
7	NC	Not internally connected
8	NC	Not internally connected

5.7.2. Connector specifications (rack)

On the Rack version, the CAN bus is accessible through a male DB-9 plug. The connector pin-out is the following:

Pin #	Name	Description
2	CAN_L	CAN Low
3	SGND	Signal Ground
7	CAN_H	CAN High

5.7.3. Electrical specifications

Parameter	Conditions	Min.	Typ.	Max.	Units
Recessive Bus Voltage		2		3	V
CAN H Output Voltage	Dominant	3.0		4.25	V
CAN L Output Voltage	Dominant	0.5		1.75	V
Differential Input Voltage	-12V ≤ Common Mode Voltage ≤ +12V	0.5	0.7	0.9	V

5.8. Serial ports interfaces

Serial port interfaces can be used to connect various external equipment and share very similar features and capabilities. Specificity of different ports is detailed in the following sections. Some of the common features are listed below:

- 4 800 to 921 600bps operation (Default set to 115 200)
- RS-232 or RS-422 modes available for most interfaces, configured by software
- Parity control enabling/disabling (disabled by default)
- Data bits: 8
- Stop bits: 1
- 1 x 12V power supply for external signal translation circuitry or powering external equipment (e.g. odometer, radio modem, conversion to TTL or RS-422). Max 3W total power supply for all ports.
- 1 x Event/Sync input associated with each port



Note: Navsight automatically limits the serial signals slew-rate to minimize EMI and reduce communication error when the baud rate is below 230 400 bps.

5.8.1. PORT A Interface

Although the PORT A shares most of the other serial ports characteristics, it has also some specific features:

- Fixed RS-232 communications
- Dedicated interface for configuration over serial using sbgECom protocol
- 1 x SYNC OUT A (RS-232 level)

5.8.1.1. SYNC Out A functionality

The Sync OUT A can be configured in two ways:

- **Main loop divider:** This event is activated at the sensor sample time, but its frequency is divided by the output divider. If the divider is set to 4, pulse output frequency will be $200 \text{ Hz} / 4 = 50 \text{ Hz}$.
- **PPS:** This simple output is synchronized with each top of UTC seconds. Validity should be checked by parsing the UTC messages status.
- **Virtual odometer.** This output generates a pulse each X meters of travel, depending on user configuration.

5.8.1.2. Connector specifications (rugged)

The PORT A connector uses an 8 ways female ODU connector (ref G81F1C-P08LFG00000). Other manufacturers such as Fischer provide compatible plugs (Fischer Core Series).The connector mates with plug ref S31F1C-P08MFG0-5500.

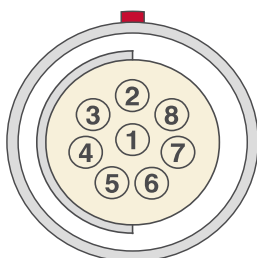

Figure 5.9: Receptacle front panel view



Figure 5.10: External plug

Connector's pin-out is the following:

Pin #	Name	Description
SHIELD	SHIELD	Connected to the mechanical ground
1	SYNC OUT A	Synchronization output signal
2	SGND	PORT A Signal ground
3	NC	Do not connect – reserved for future use
4	TX	PORT A Tx
5	RX	PORT A Rx
6	NC	Do not connect – reserved for future use
7	SYNC IN A	Synchronization input A
8	+12V	+12V power supply output – may be used for signal adaptation circuitry

5.8.1.3. Connector specifications (rack)

On the Rack version, the PORT A is accessible through a standard male DB-9 plug.

For easier external event interfacing, the SYNC IN A is not accessible through the DB-9 plug, but a dedicated BNC connector is used instead.

Pin #	Name	Description
SHIELD	SHIELD	Connected to the mechanical ground
2	RX	PORT A RS-232 Rx
3	TX	PORT A RS-232 Tx
4	SYNC OUT A	
5	SGND	Signal ground

SYNC IN A BNC connector pin-out:

Pin #	Name	Description
Center	SYNC_IN_A	SYNC IN A
Outer	S GND	Signal ground

5.8.1.4. Electrical specifications

Parameter	Conditions	Min.	Typ.	Max.	Units
RS-232 Receiver, Sync In A					
Input range		-12		12	V
Low level threshold		0.6	1.2		V
Input resistance		3	5	7	k Ω
RS-232 Transmitters, Sync Out A					
Output range		+/-5		+/-5.5	V
+12V Power output					

Parameter	Conditions	Min.	Typ.	Max.	Units
Max output current			150		mA

5.8.2. PORT B, C and D interfaces

PORT B, C and D share all the common specifications with other serial interfaces. They can be used as general purpose data input/output. They operate in both RS-232 or RS-422 and include Sync In pin as well as +12V output for signal translation purpose.

5.8.2.1. Connector specifications (rugged)

The PORT B, C and D connectors use an 8 ways female ODU connector (ref G81F1C-P08LFG00000). Other manufacturers such as Fischer provide compatible plugs (Fischer Core Series). The connector mates with plug ref S31F1C-P08MFG0-5500.

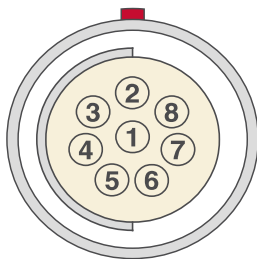

Figure 5.11: Receptacle front panel view



Figure 5.12: External plug

Connector's pin-out is the following:

Pin #	Name	Description
SHIELD	SHIELD	Connected to the mechanical ground
1	NC	Not internally connected
2	SGND	Signal ground
3	TX+	RS-422 Tx+
4	TX- / TX	RS-422 Tx- / RS-232 Tx
5	RX+ / RX	RS-422 Rx+ / RS-232 Rx
6	RX-	RS-422 Rx-
7	SYNC IN #	Synchronization input B, C, or D
8	+12V	+12V power supply output – may be used for signal adaptation circuitry

5.8.2.2. Connector specifications (rack)

On the Rack version, the PORT B, C, D are accessible through a standard male DB-9 plug.

Pin #	Name	Description
SHIELD	SHIELD	Connected to the mechanical ground
1	SYNC_IN_#	Synchronization input B or C or D
2	RX+ / RX	RS-422 Rx+ / RS-232 Rx
3	TX- / TX	RS-422 Tx- / RS-232 Tx
5	SGND	Signal ground
6	RX-	RS-422 Rx-
7	TX+	RS-422 Tx+

5.8.2.3. Electrical specifications

Parameter	Conditions	Min.	Typ.	Max.	Units
RS-232 Receiver, Sync In pins					
Input range		-12		12	V
Low level threshold		0.6	1.2		V
			1.5	2.0	V
Input resistance		3	5	7	k Ω
RS-422 Receivers					
Input differential threshold		-200	-125	-50	mV
Input hysteresis			25		mV
Input resistance		100	120	155	k Ω
RS-232 Transmitters					
Output range		+/-5		+/-5.5	V
RS-422 transmitters					
Differential output voltage		1.5			V
Common mode output voltage				3	V
+12V Power output					
Max output current			150		mA

5.8.3. PORT E interface

PORT E can be used for all common inputs and outputs functions. In addition to that the PORT E is the dedicated interface for Odometer (DMI) connection.

A dedicated +12V power supply is available on PORT E connector for easy connection with most precision odometers.

5.8.3.1. Connector specifications (rugged)

The PORT E connector uses an 8 ways female ODU connector (ref G81F1C-P08LFG00000). Other manufacturers such as Fischer provide compatible plugs (Fischer Core Series). The connector mates with plug ref S31F1C-P08MFG0-5500.

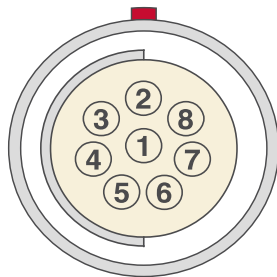

Figure 5.13: Receptacle front panel view



Figure 5.14: External plug

Connector's pin-out is the following:

Pin #	Name	Description
SHIELD	SHIELD	Connected to the mechanical ground
1	NC	Not internally connected
2	SGND	PORT E Signal ground
3	TX+	RS-422 Tx+
4	TX- / TX	RS-422 Tx- / RS-232 Tx
5	RX+ / RX / ODO A	RS-422 Rx+ / RS-232 Rx / ODO A input
6	RX-	RS-422 Rx-
7	SYNC IN E / ODO B	Synchronization input / ODO B input
8	+12V	+12V power supply output – may be used for odometer power

5.8.3.2. Connector specifications (rack)

On the Rack version, the PORT E is accessible through a standard male DB-9 plug.

Pin #	Name	Description
SHIELD	SHIELD	Connected to the mechanical ground
1	SYNC_IN_E / ODO B	Synchronization input E / Odometer input B
2	RX+ / RX / ODO A	RS-422 Rx+ / RS-232 Rx / ODO A input
3	TX- / TX	RS-422 Tx- / RS-232 Tx
5	SGND	PORT E Signal ground
6	RX-	RS-422 Rx-
7	TX+	RS-422 Tx+

5.8.3.3. Electrical specifications

Parameter	Conditions	Min.	Typ.	Max.	Units
RS-232 Receiver, Sync In E					
Input range		-12		12	V
Low level threshold		0.6	1.2		V
			1.5	2.0	V
Input resistance		3	5	7	kΩ
RS-422 Receivers					
Input differential threshold		-200	-125	-50	mV
Input hysteresis			25		mV
Input resistance		100	120	155	kΩ
RS-232 Transmitters					
Output range		+/-5		+/-5.5	V
RS-422 transmitters					
Differential output voltage		1.5			V
Common mode output voltage				3	V
+12V Power output					
Max output current			150		mA

5.9. SYNC OUT B

SYNC Out B is the main synchronization output interface. Directly accessible on the back panel through a standard BNC connector. It can operate in two different ways:

- **Main loop divider:** This event is activated at the sensor sample time, but its frequency is divided by the output divider. If the divider is set to 4, pulse output frequency will be $200 \text{ Hz} / 4 = 50 \text{ Hz}$.
- **PPS:** This simple output is synchronized with each top of UTC seconds. Validity should be checked by parsing the UTC messages status.
- **Virtual odometer.** This output generates a pulse each X meters of travel, depending on user configuration.

5.9.1.1. Electrical specifications

Parameter	Conditions	Min.	Typ.	Max.	Units
PPS output					
Low level output voltage		0	0.1	0.55	V
High level output voltage		3.8	4.9	5	V
Output Current		-30	-	30	mA

5.10. SYNC In A, B, C, D and E

Each serial interface is associated with a synchronization input signal. The Sync IN pins can be used for various functions:

- **Output log trigger:** All pulses received generate events that can generate specific Logs output. Any output log can be triggered by an event pulse. Navsight can handle up to 200 Hz triggers.
- **Event Marker:** Events up to 1 kHz are supported on each pin.
- **PPS input**
- **External aiding data time-stamping**

See section PORT A Interface for details about each pin-out and electrical specifications.

5.11. GNSS antenna connectors

To connect external GNSS antennas, Navsight features two TNC connectors that provide IP-68 protection even unmated. The internal GNSS receiver only supports active GNSS antennas.



Figure 5.16: GNSS antenna connector



Figure 5.15: Typical TNC antenna cable

Any standard coax cable with a TNC male connector can be used with Navsight. However, care should be taken to select a high quality coaxial cable with low loss in case of long cable. It is also required to use a very similar setup on both antennas:

- Same antenna type
- Same cable type and length
- Same antenna orientation

Please be advise that Navsight doesn't implement any lightning protection. The GNSS antenna and cable are very sensitive to strikes and a proper installation with lightning protection devices may be required.



Note: For best performance, the antenna(s) should be connected before the power is applied. The Navsight GNSS receiver estimates the noise floor of the antenna during the startup sequence.



Note 2: Navsight-E versions do not include a GNSS receiver. The TNC connectors present on the back side are left unconnected internally.

5.11.1. Electrical specifications

Parameter	Specifications
LNA supply voltage	5 VDC
Recommended LNA gain range	15-45 dB (Navsight-S) > 32 dB (Navsight-T)
LNA supply current	< 150 mA per antenna (Navsight-S) < 200 mA per antenna (Navsight-T)

5.11.2. GNSS antenna advice

Navsight-S and -T embed a high performance, triple frequency GNSS receiver.

For optimal performance, SBG Systems recommends the use of geodetic multi-frequency, multi-constellation GNSS antennas.

SBG Systems has selected some high quality GNSS antennas for different applications. Please refer to the support center to get more details on available antennas.

5.12. Internal Datalogger

Navsight includes an internal data-logger capable of storing all data at 200 Hz for 48 hours. The internal data-logger is composed of a high speed memory buffer and an 8 GB flash storage.

Access to the logged data is ensured by accessing the FTP server.

5.13. Power supply interface

The power supply uses a 2 ways male Push-pull ODU connector reference G81F1C-P02MPH00000. The connector mates with the following plug reference: S31F1C-P02LPN0-350S. It is also compatible with other manufacturers such as Fischer Core Series.

Both Rugged processing unit and rack processing unit use the same power connector.

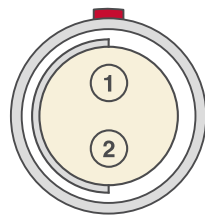

Figure 5.17: Power receptacle front view



Figure 5.18: Power plug top view



Note: Power connector share the same specifications & pin-out as Ekinox, Apogee surface units, as well as Splitbox units. However, previously provided power supplies may not provide sufficient current outputs for Navsight operation.

5.13.1. Connector pin-out

Pin #	Name	Description
SHIELD	SHIELD	Connected to mechanical ground
1	VIN+	Power supply input
2	VIN-	Power supply return

5.13.2. Electrical specifications

Parameter	Min.	Typ.	Max.	Units	Conditions
Operating voltage	12	24	36	VDC	
Power consumption		7		W	Navsight-E with Ekinox-I
		9		W	Navsight-E with Apogee-I
	8	10		W	Navsight-T/S with Ekinox-I
	10	12		W	Navsight-T/S with Apogee-I
Allowable Input Voltage Ripple			400	mV p-p	
Under voltage lock out		11.5		V	Turn on threshold
		8.5		V	Turn off threshold
Galvanic Isolation			250	VDC	VIN+ to Mechanical Ground VIN- to Mechanical Ground

5.14. Typical wiring recommendations

In this section, we briefly describe a few recommended wiring diagrams.

5.14.1. Power supply connection

Concerning power supply, we recommend shielded cable, with at least AWG 24 wires.

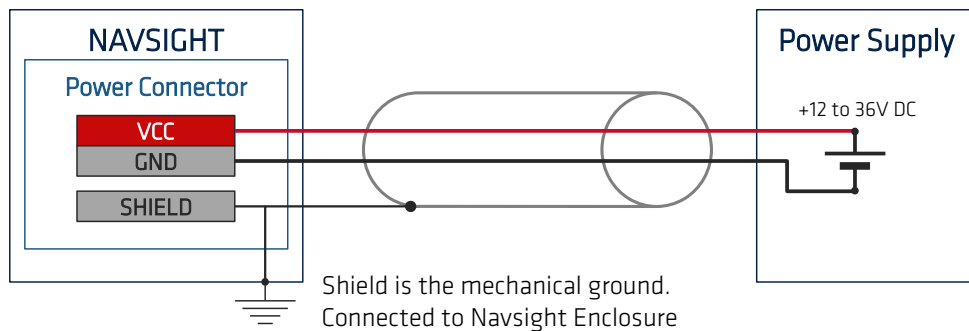

Figure 5.19: Power supply wiring connections

5.14.2. Main interface connection on RS-232

Below is shown the main interface (Port A) connection, using a full duplex RS-232 connection. The recommended cable is a shielded AWG 26 cable.

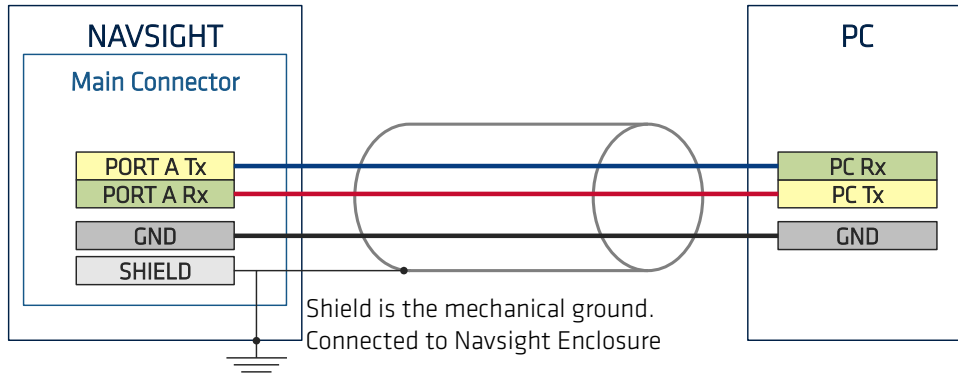

Figure 5.20: Main serial interface full duplex connection in RS-232

5.14.3. CAN Bus typical wiring

CAN bus is designed to operate with low cost twisted pairs cables. The bus may be terminated by a single 60 Ω resistor, or multiple resistors on each bus ends (as long as the equivalent parallel impedance is 60 Ω). This resistor is not present in the rugged processing unit.

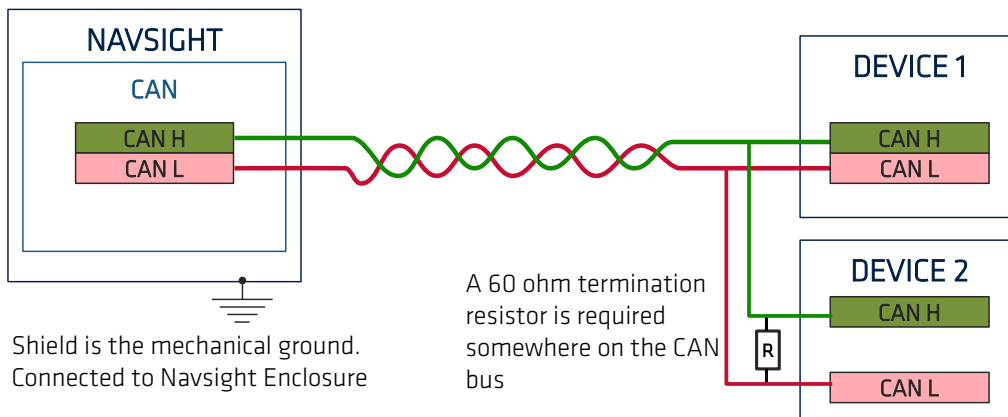

Figure 5.21: Basic CAN bus wiring

5.14.4. GNSS connection in RS-232 mode

For this typical connection, a shielded 26 AWG cable should be used. Depending on PPS signal strength, we do not recommend this cable to measure more than a few meters. For long distance, PPS signal and GNSS NMEA signals should be separated in two cables for better noise immunity.

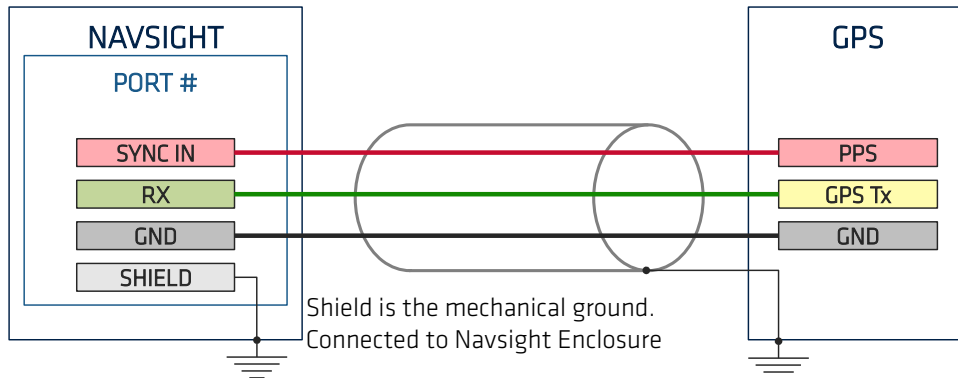

Figure 5.22: Typical wiring diagram for Navsight with external GNSS receiver

5.14.5. Duplex interfacing in RS-422

Below is shown a serial port interface, configured using a full duplex RS-422 operation. The recommended cable is a shielded twisted pairs 26 AWG cable, and a termination resistor should be placed at receiver side.

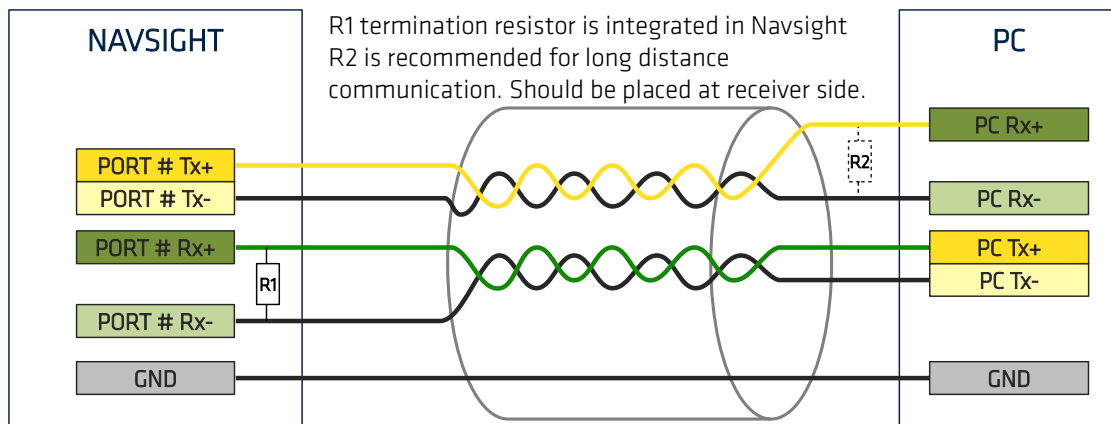

Figure 5.23: Main serial interface full duplex connection in RS-422 mode

5.15. Typical connection topology

The following use cases are presented to quickly show how to connect the Navsight solution various external equipment in different applications.

5.15.1. Navsight use in Land/Air survey applications

In this setup we use Navsight solution as navigation sensor for any land or air survey application

- IMU can be installed remotely, where it's convenient to the user (e.g. close to LIDAR sensor)
- Two antennas are connected directly on the Navsight processing unit
- Serial RTK corrections are sent to Navsight unit through PORT D
- If applicable, the odometer (DMI) pulses are connected to Navsight PORT E
- Timing information is sent to LIDAR using standard RMC message and PPS
- Ethernet interface is used for
 - Real time data display on sbgCenter or any dedicated software
 - Get back the mission RAW data (IMU + GNSS) for post-processing purpose using Qinertia using embedded FTP server

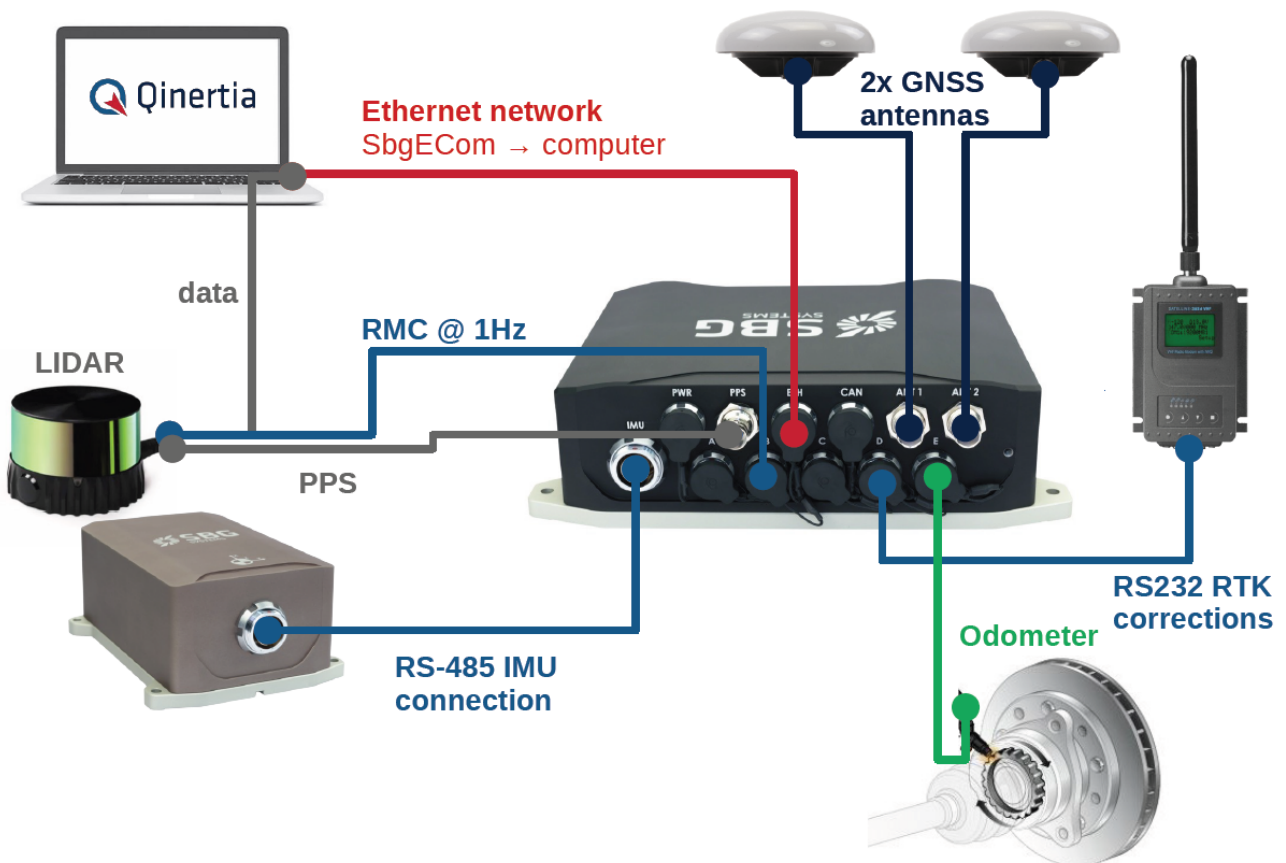

Figure 5.24: Navsight typical connections in an advanced automotive application

5.15.2. Navsight use in marine applications

In the next diagram, the Navsight unit is used as motion and navigation sensor for a multi-beam echo sounder survey application.

- IMU is located close to the Sonar head – or at any place convenient for the user
- Two antennas are rigidly installed on top of the vessel
- Serial RTK corrections are received on the PORT D
- Ethernet interface is used to:
 - send back motion information to the MBES top-side unit.
 - Record real time navigation outputs in the survey software (QPS, Hypack, PDS, or any other dedicated software)
 - Get full mission raw IMU + GNSS data for post-processing purpose on Qinertia through the FTP server

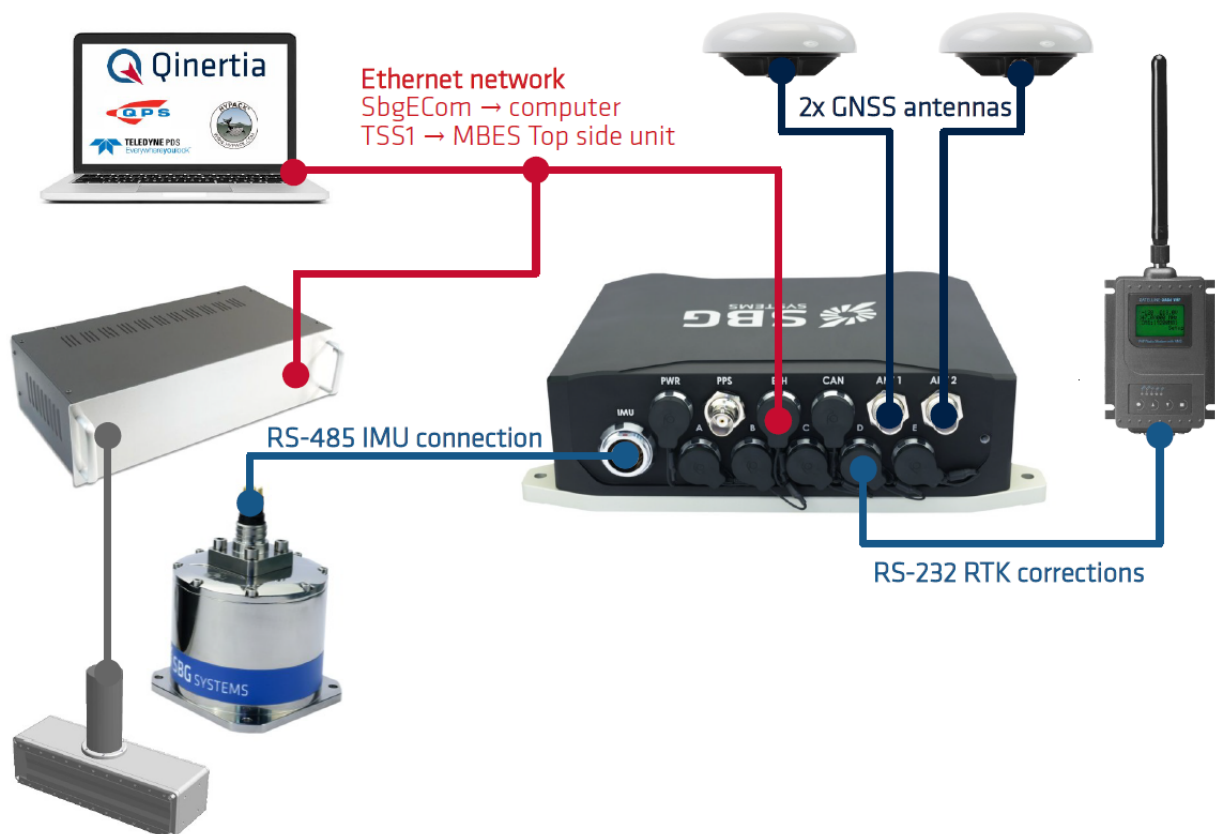

Figure 5.25: Navsight use in typical Marine survey application

6. Important notices

6.1. Maintenance

Navsight solution does not require particular maintenance when operated in normal conditions. Nevertheless, if you would like to maintain your sensor performance to the highest level, SBG Systems can provide a maintenance service with regularly planned checkups and calibrations.

When used in harsh environments, please use damp clothes to clean the surface of the Enclosure.

6.1.1. Subsea enclosures maintenance

Subsea enclosures are made out of Titanium to prevent corrosion issues. However, care should be taken to regularly rinse the enclosure with clear water after use in salt water.

Additionally, the subsea connectors are made in Chloroprene rubber. In order to maintain all their mechanical properties, the cable connectors need to be regularly greased with a silicon compound such as Molykote 44 medium. Failing to do so can lead to the fusion of connector plug and receptacle.

6.2. Absolute maximum ratings

Stresses above those listed under the Absolute Maximum Ratings may cause permanent damage to the device. This is a stress rating only; functional operation of the device at these or any other conditions above those indicated in the operational section of this specification is not implied. Exposure to absolute maximum rating conditions for extended periods may affect device reliability.

6.2.1. Processing units

Parameter	Rating
VDD – GND	+/- 36 V
Galvanic isolation: Power supply input to chassis ground Signal grounds to chassis ground	+/- 250 V
Rx+, Rx-, Logic inputs pins input voltage to signal SGND	±12 V
Logic output Max current	SYNC OUT A: 35 mA
CANH, CANL	±36 V
Shock	500 g for 0.3 ms

Table 1: Absolute maximum ratings

6.2.2. IMU modules

Parameter	Rating
VDD – GND	+/- 36 V
Galvanic isolation between various GND pins	+/- 250 V
Rx+, Rx-, Logic inputs pins input voltage to signal GND	±18 V
Shocks	500 g for 0.3 ms

Table 2: Absolute maximum ratings

6.3. Support

Our goal is to provide the best experience to our customers. If you have any question, comment or problem with the use of your product, we would be glad to help you, so feel free to contact us to our standard email address support@sbg-systems.com.

6.4. Warranty, liability and return procedure

SBG Systems provides a warranty covering this product against any defect in materials or manufacture for a period of two (2) years from the date of shipment. In the event that such a defect becomes obvious during the stipulated warranty period, SBG Systems will undertake, at its sole discretion, either to repair the defective product, bearing the cost of all parts and labor, or to replace it with an identical product.

In order to avail itself of this warranty, Customer must notify SBG Systems of the defect before expiry of the warranty period and take all steps necessary to enable SBG Systems to proceed. Upon reception of required information (Sensor serial number, defect description), SBG Systems will issue an RMA and will provide return instructions. Customer shall be responsible for the packaging and the shipment of the defective product to the repair center notified by SBG Systems, the cost of such shipment being borne by Customer.

This warranty shall not be construed as covering defects, malfunctions or damages caused by improper use or inadequate maintenance of the product. Under no circumstances shall SBG Systems be due to provide repair or replacement under this warranty in order a) to repair damage caused by work done by any person not representing SBG Systems for the installation, repair or maintenance of the product; b) to repair damage caused by improper use or connection to incompatible equipment, and specifically, the opening of the housing of the equipment under warranty shall cause the warranty to be automatically canceled.

This warranty covers the product hereunder and is provided by SBG Systems in place of all and any other warranty whether expressed or implied. SBG Systems does not guarantee the suitability of the product under warranty for sale or any specific use.

SBG Systems liability is limited to the repair or replacement of defective products, this being the sole remedy open to Customer in the event the warranty becomes applicable. SBG Systems cannot be held liable for indirect, special, subsequent or consequential damage, irrespective of whether SBG Systems has or has not received prior notification of the risk of occurrence of such damage.

7. Appendix A: Ordering codes and Accessories

7.1. Ekinox IMU Ordering codes

The following Ekinox IMU variants are available to order. Please contact your sales representative for more information.

Navsight Variant

EKINOX-I-B | Marine - IMU

EKINOX-I-S | Marine - Subsea IMU

EKINOX-I-B | Land Air - IMU

7.2. Apogee IMU Ordering codes

The following Apogee IMU variants are available to order. Please contact your sales representative for more information.

Navsight Variant

APOGEE-I-B | Surface - IMU

APOGEE-I-S | Subsea IMU

7.3. Horizon IMU Ordering code

The Horizon IMU will be ordered with following code: **HORIZON-I-C-B**.

7.4. Processing unit variants

The following Navsight processing unit variants are available to order. Please contact your sales representative for more information.

Navsight Variant

NAVSIGHT-E	Rugged - Land Air INS
NAVSIGHT-E	Rugged - Marine MRU
NAVSIGHT-E	Rugged - Marine INS
NAVSIGHT-E	Rack - Land Air INS
NAVSIGHT-E	Rack - Marine MRU
NAVSIGHT-E	Rack - Marine INS
NAVSIGHT-T	Rugged - Land Air INS - GNSS
NAVSIGHT-T	Rugged - Marine INS - GNSS
NAVSIGHT-T	Rack - Land Air INS - GNSS
NAVSIGHT-T	Rack - Marine INS - GNSS
NAVSIGHT-S	Rugged - Land Air INS - GNSS
NAVSIGHT-S	Rugged - Marine INS - GNSS
NAVSIGHT-S	Rack - Land Air INS - GNSS
NAVSIGHT-S	Rack - Marine INS - GNSS

7.5. Transport Cases

7.5.1. CASE-NAVS-04

This larger transport case can be used to securely ship or stock:

- An Ekinox or Apogee IMU (Subsea units)
- A Navsight Rugged or rack processing unit
- 20M+ of IMU ↔ processing cable
- Various cables and accessories
- 2x survey antennas + associated TNC cables



Figure 7.1: 9.2.2. CASE-NAVS-04

7.6. Associated Software

7.6.1. Qinertia (Post-processing software)

Qinertia is the dedicated software for all post-processing applications. When high performance is a must, or in case of harsh environments, Qinertia provides a cutting edge, tightly coupled GNSS/INS PPK solution. In addition, Navsight users benefit from a seamless integration with Qinertia.

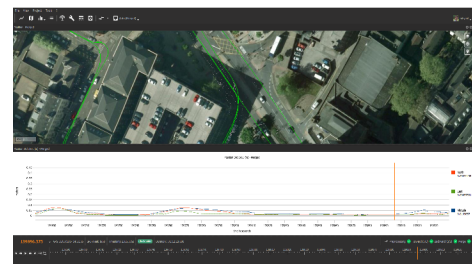

Figure 7.2: QInertia Post-processing suite

Contact sales team for more information about Qinertia. SBG Systems

7.6.2. Inertial SDK (Software Development Kit)

The Inertial Software Development Kit is very helpful to configure, playback recorded logs, export data to text files or third party software and even develop custom code for Navsight.

Inertial SDK can be freely downloaded from our support center.

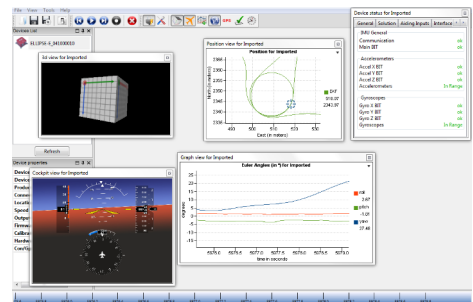

Figure 7.3: sbgCenter analysis tool

7.7. Cables

7.7.1. IMU cables

Various IMU ↔ processing cables configurations are provided to suit all application needs. Two lengths are proposed for surface IMUs and two lengths are proposed for Subsea IMUs. In addition, standard cable extenders are provided to meet long distance applications needs.

7.7.1.1. CA-NAVS-IMU-STD-#M

This cable is used for surface IMU models and can be delivered in 5 or 10 meters lengths.

- CA-NAVS-IMU-STD-5M
- CA-NAVS-IMU-STD-10M



Figure 7.4: CA-NAVS-IMU-STD-10M

7.7.1.2. CA-NAVS-IMU-SUB-#M

This cable is used for subsea IMU models and can be delivered in several lengths to fulfill each customer requirement.

- CA-NAVS-IMU-SUB-5M
- CA-NAVS-IMU-SUB-10M
- CA-NAVS-IMU-SUB-20M
- CA-NAVS-IMU-SUB-50M



Figure 7.5: CA-NAVS-IMU-SUB-20M

7.7.1.3. CA-NAVS-IMU-EXT-#M

This cable extender can be used to enlarge any type of IMU cable (surface or subsea). It is IP-68 rated, but is not suitable for long exposure to salt water. It can be delivered in 10 or 20 meters lengths.

- CA-NAVS-IMU-EXT-10M
- CA-NAVS-IMU-EXT-20M

7.7.2. CA-PWR-24-60-CC-4M

This cable is an international AC/DC adapter to power up Navsight solution. It has the following features

- 110 / 250 V input
- 24V output, 60W power
- 2.5m US, UK and EU extension cords
- 1.8m DC cable length
- No IP rating



Figure 7.6 : AC / DC power adapter



Note: This cable is included in the rugged processing unit package. It can also be ordered separately.

7.7.3. CA-AEK-PWR-3M

This cable mates with the PWR connector to power up the Navsight solution from an external power supply.

- 1 x ODU Mini-Snap F Series S31F1C-P02LPN0-0002 plug
- 1 x open end
- IP-68 rating
- 3m long 18AWG cable
- Weight: 170g



Figure 7.7 : Alternative Power cable

Cable wiring is:

Pin	Signal	Color
SHIELD	NC	SHIELD
1	VIN+	Red
2	VIN-	Black

7.7.4. CA-NAVS-ETH-5M

This cable provides a direct access to Ethernet network thanks to its RJ-45 plug.

- Direct connection on ETH port
- 1 x RJ-45 connector for Ethernet connection.
- 5 m cable (CAT6 type)
- Weight: 120g



Figure 7.8 : Ethernet cable



Note: This cable is included in the rugged processing unit package. It can also be ordered separately.

7.7.5. CA-NAVS-COM-2M

This open ended cable connects on any serial port or CAN bus plug of the rugged processing unit. It has the following characteristics:

- 1 x ODU Mini-Snap F Series S31F1C-P08MFG0-5500 plug
- 1x open end
- IP-68 rating
- 2m long



Figure 7.9 : Open ended COM cable

Pin on ODU plug	Signal on serial ports	Signal on CAN port	Color
1	SYNC_OUT/NC	-	GREY
2	GND	-	BLACK
3	TX+	CAN H	WHITE
4	TX / TX-	GND	BLUE
5	RX / RX+	CAN L	YELLOW
6	RX-	-	ORANGE
7	SYNC_IN	-	RED
8	+12V out	-	GREEN

7.7.6. CA-NAVS-COM-DB-0.3M

This cable is a general purpose communication cable, that can be connected on each serial port available in the rugged processing unit, as well as on the CAN bus connector. General characteristics are the following

- 1 x ODU Mini-Snap F Series S31F1C-P08MFG0-5500 plug
- 1x Male DB-9 plug
- IP-68 rating
- 30cm long



Figure 7.10 : DB-9 cable adapter

Cable wiring depends on the port on which user will connect the cable and is as follows

Pin on DB-9 plug	PORT A	PORT B/C/D/E	CAN
1	SYNC IN A	SYNC IN	-
2	PORT A RX	PORT # RX / RX+	CAN L
3	PORT A TX	PORT # TX / TX-	SGND
4	SYNC OUT A	NC	-
5	SGND	SGND	-
6	-	RX-	-
7	-	TX+	CAN H
8	-	-	-
9	-	-	-



Note: This cable is included in the rugged processing unit package (3x units). It can also be ordered separately.

7.7.7. CA-NAVS-SPLIT-COM-0.5M

This cable is designed for easy external GNSS integration, thanks to dedicated RS-232/RS-422 serial connector and a PPS input connector. General characteristics are the following

- 1 x ODU Mini-Snap F Series S31F1C-P08MFG0-5500 plug
- 1x Male DB-9 plug
- 1x BNC plug for PPS input (SYNC IN)
- IP-68 rating
- 50cm long



Figure 7.11 : Splitter cable adapter

Cable wiring depends on the port on which user will connect the cable and is as follows

Pin on DB-9 plug	PORT A	PORT B/C/D/E
1	-	-
2	PORT A RX	PORT # RX / RX+
3	PORT A TX	PORT # TX / TX-
4	SYNC OUT A	NC
5	SGND	SGND
6	-	RX-
7	-	TX+
8	-	-
9	-	-



Note: This cable is included in the rugged processing unit package in its external GNSS version (-E). It can also be ordered separately.

8. Appendix B: Sub-systems mechanical outlines

All dimensions are in mm.

8.1. Ekinox IMU – Surface enclosure

8.1.1. Top View

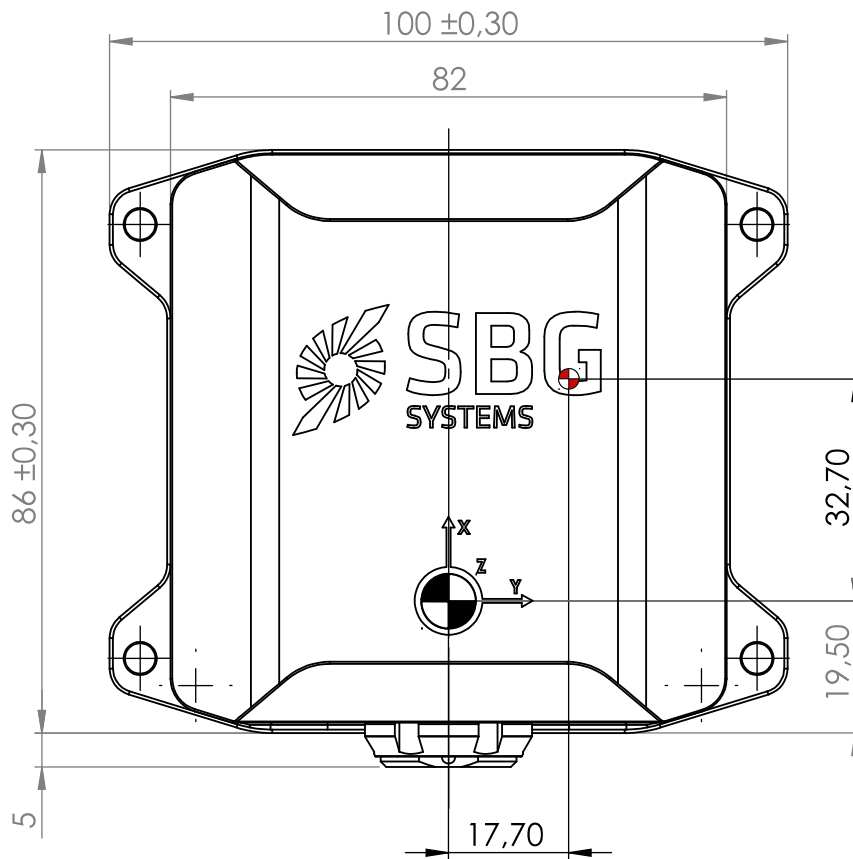

8.1.2. Right view

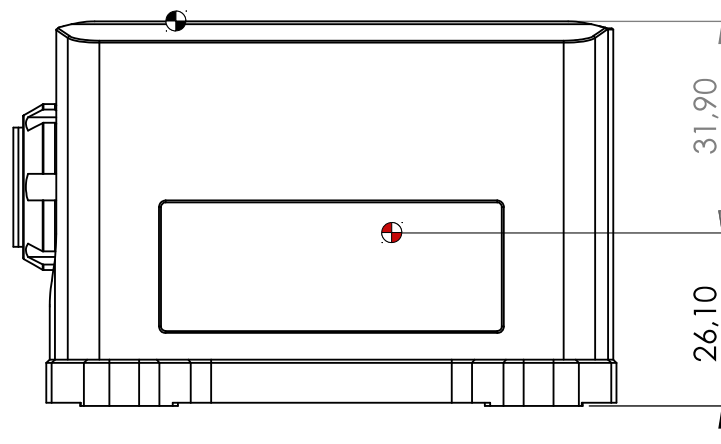

8.1.3. Front view

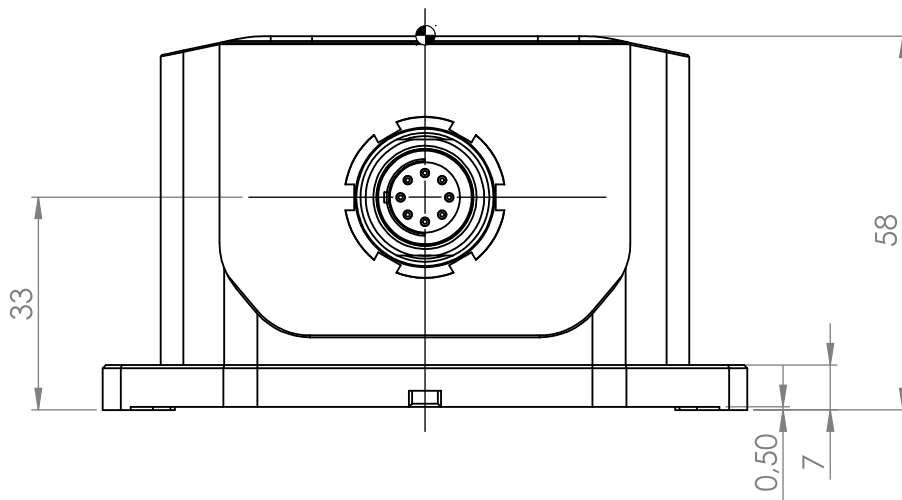

8.1.4. Bottom view

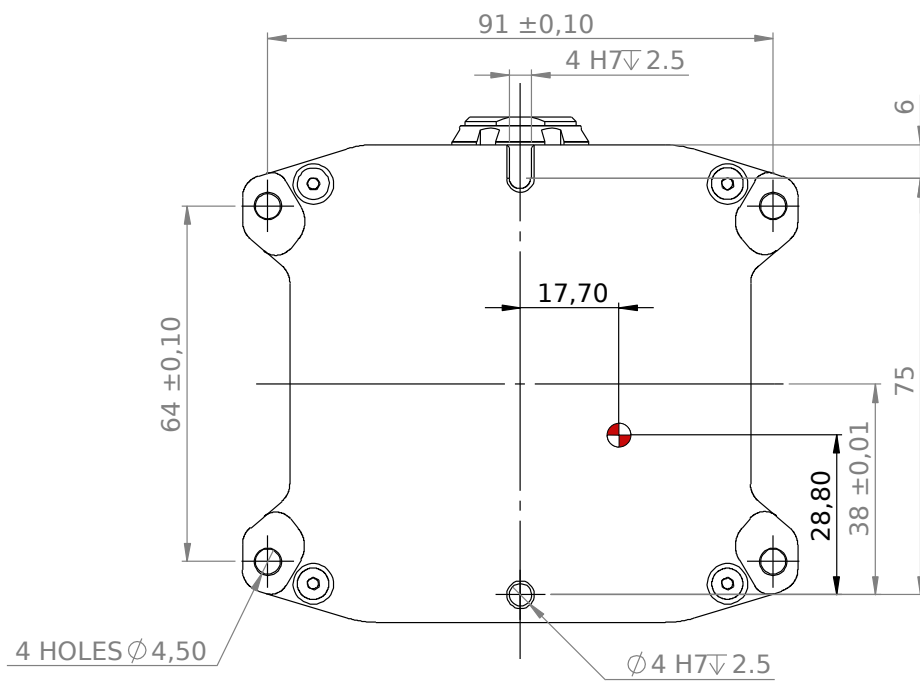

8.2. Ekinox IMU – Subsea enclosure

8.2.1. Top and bottom views

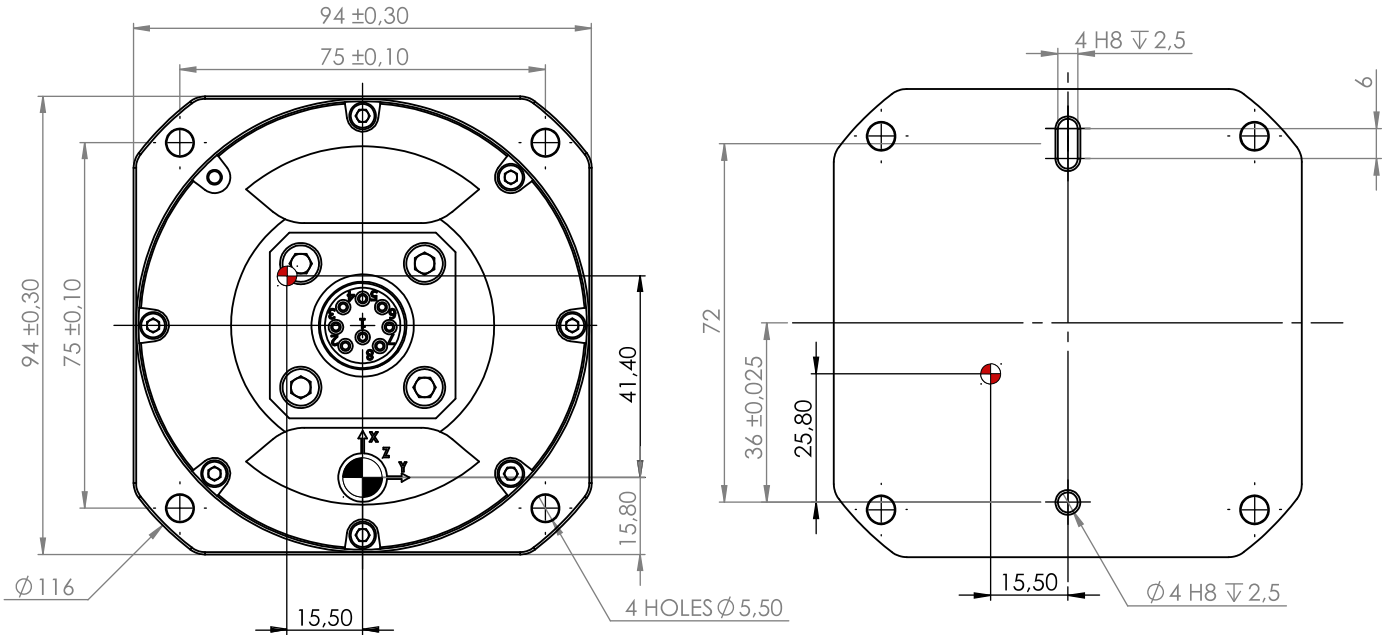

8.2.2. Front view

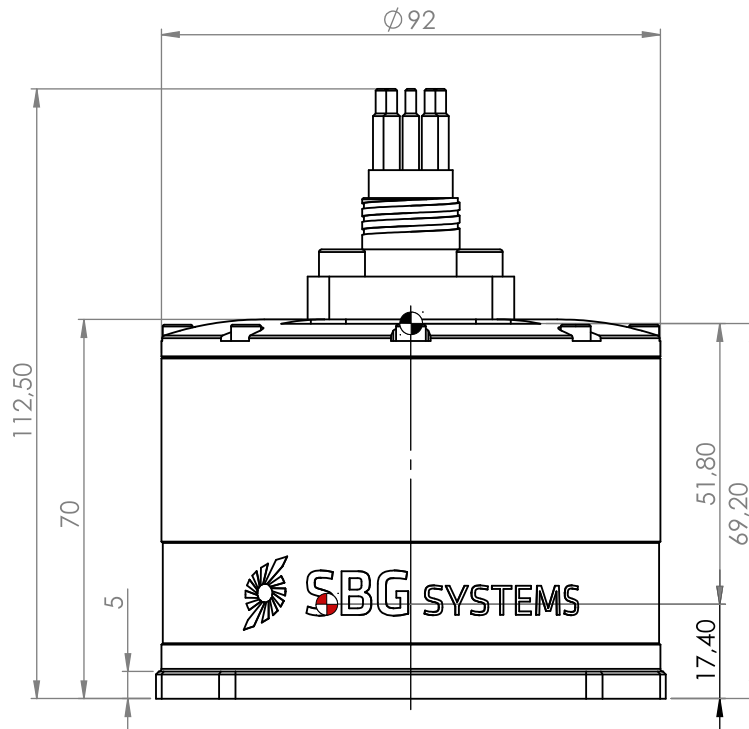

8.3. Apogee IMU - Surface enclosure

8.3.1. Top view

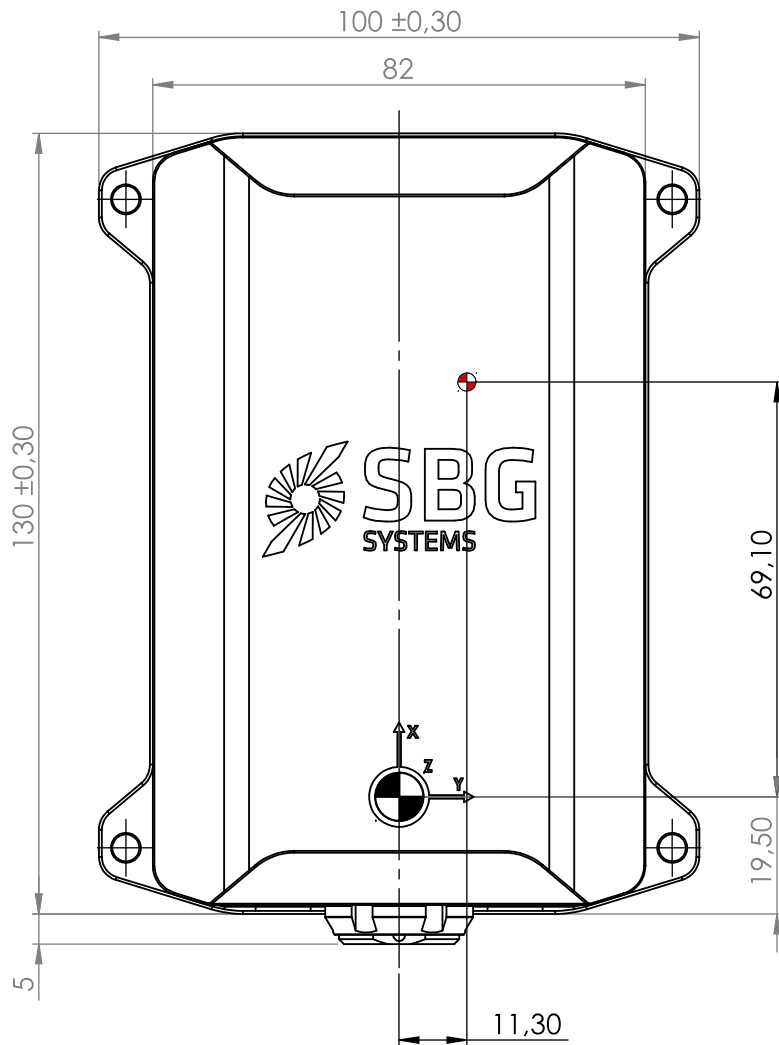

8.3.2. Right view

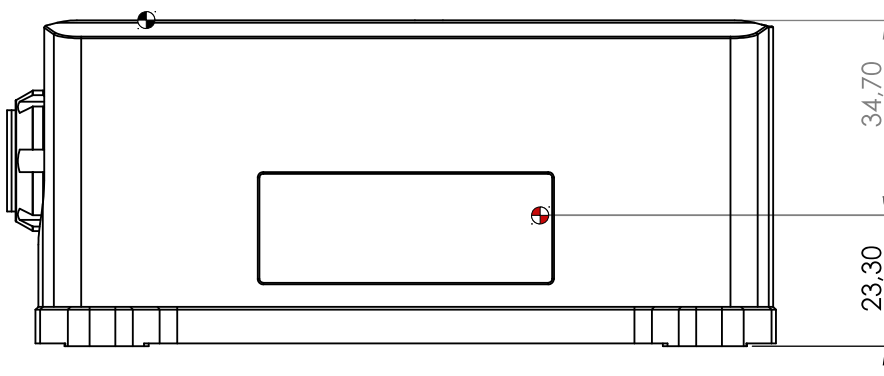

8.3.3. Front view

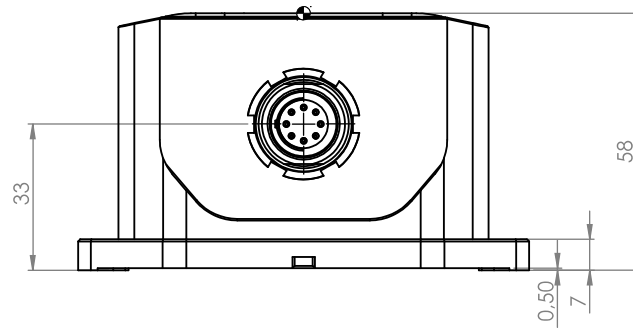

8.3.4. Bottom view

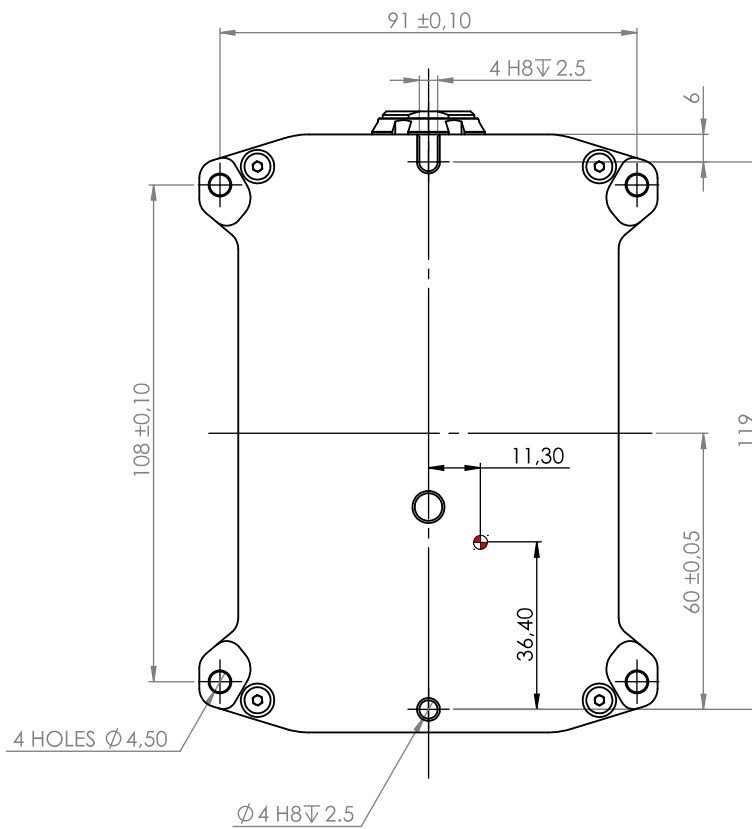

8.4. Apogee IMU – Subsea enclosure

8.4.1. Top and bottom views

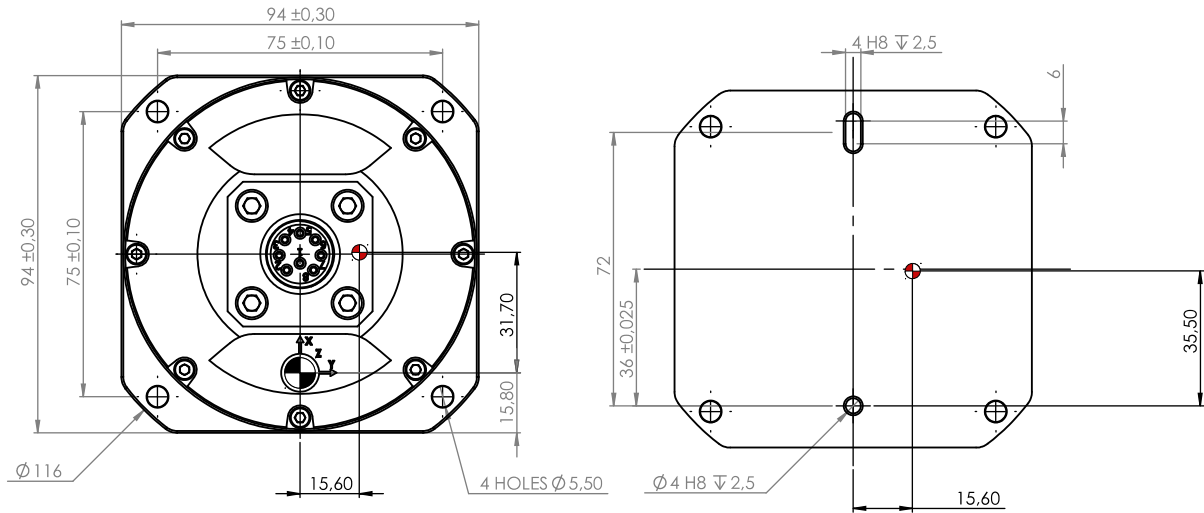

8.4.2. Front view

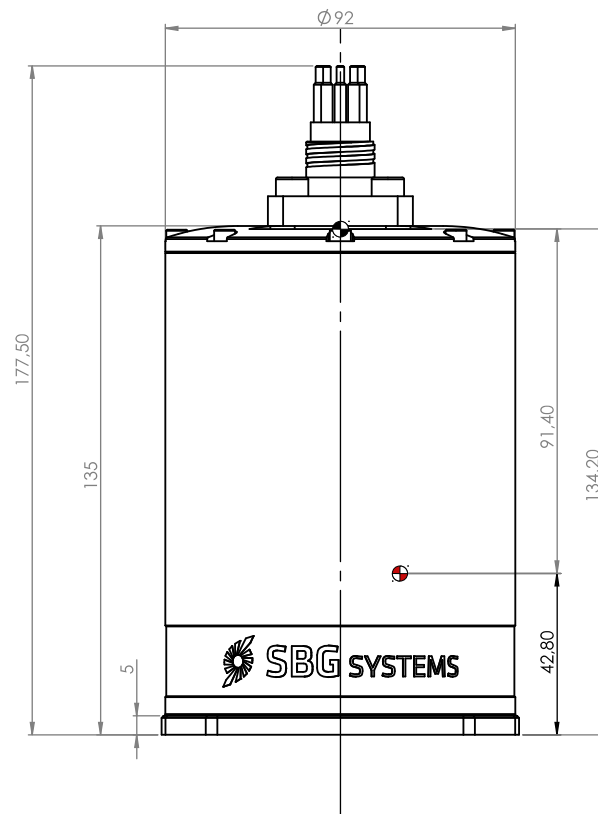

8.5. Horizon IMU

8.5.1. Top view

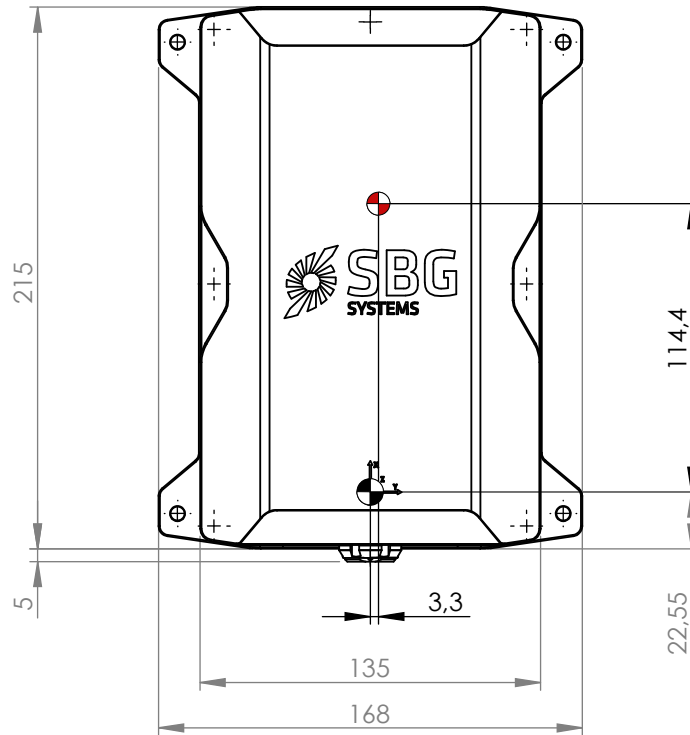

8.5.2. Right view

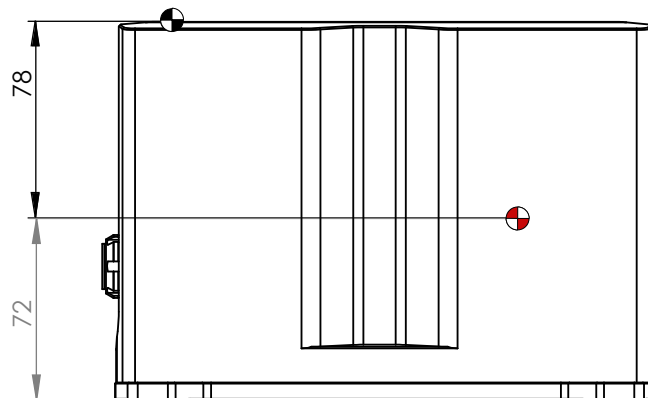

8.5.3. Front view

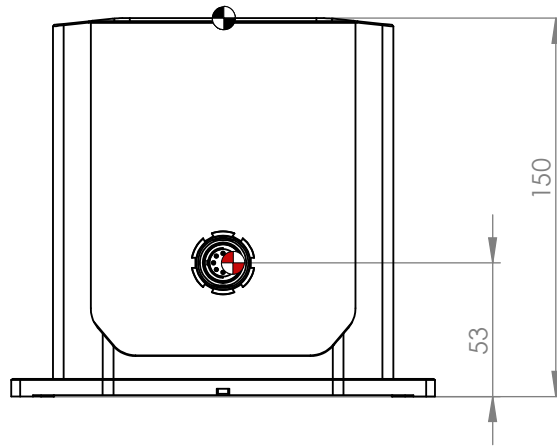

8.5.4. Bottom view

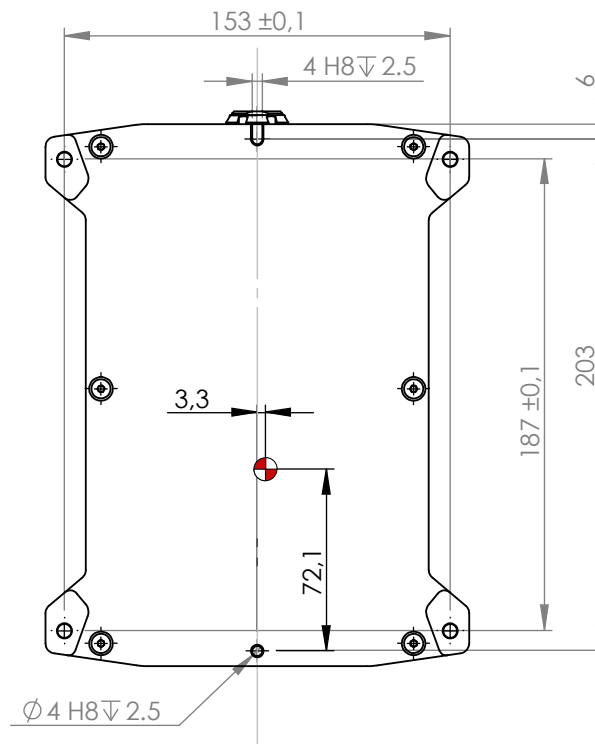

8.6. Processing unit - Rugged enclosure

8.6.1. Top view

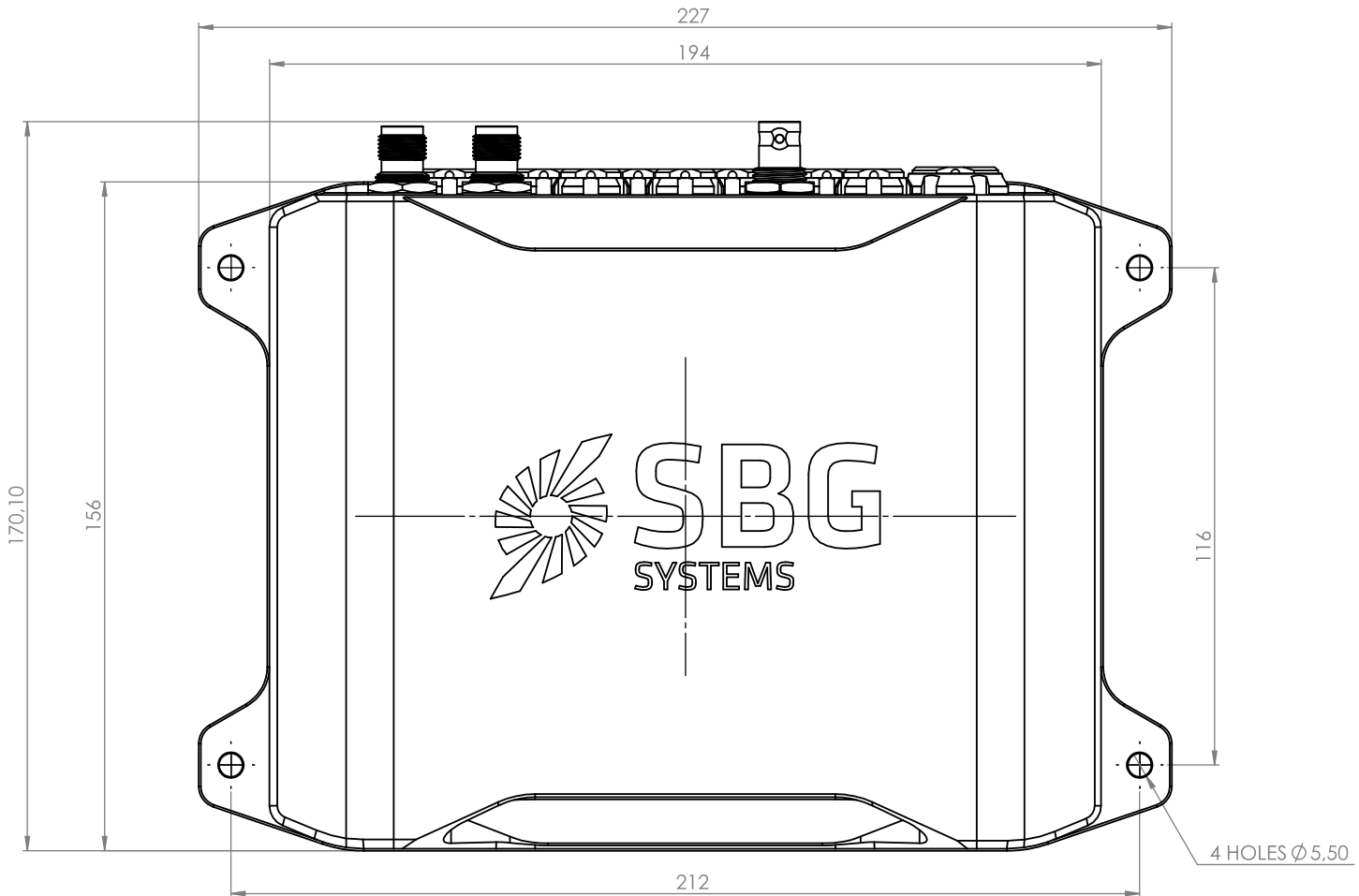

8.6.2. Right view

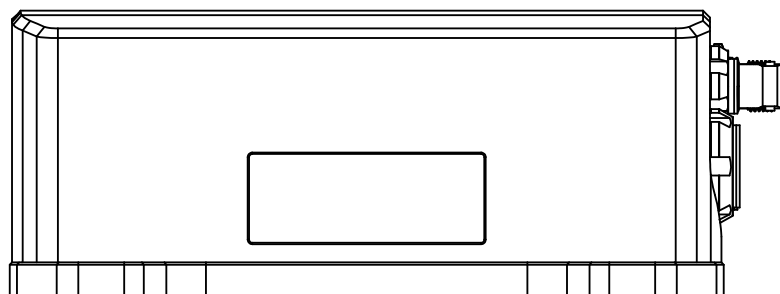

8.6.3. Front view

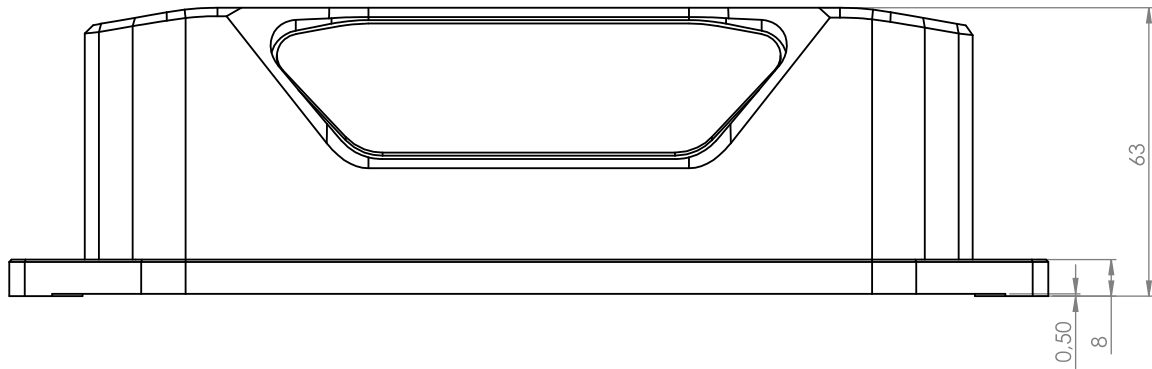

8.6.4. Back view

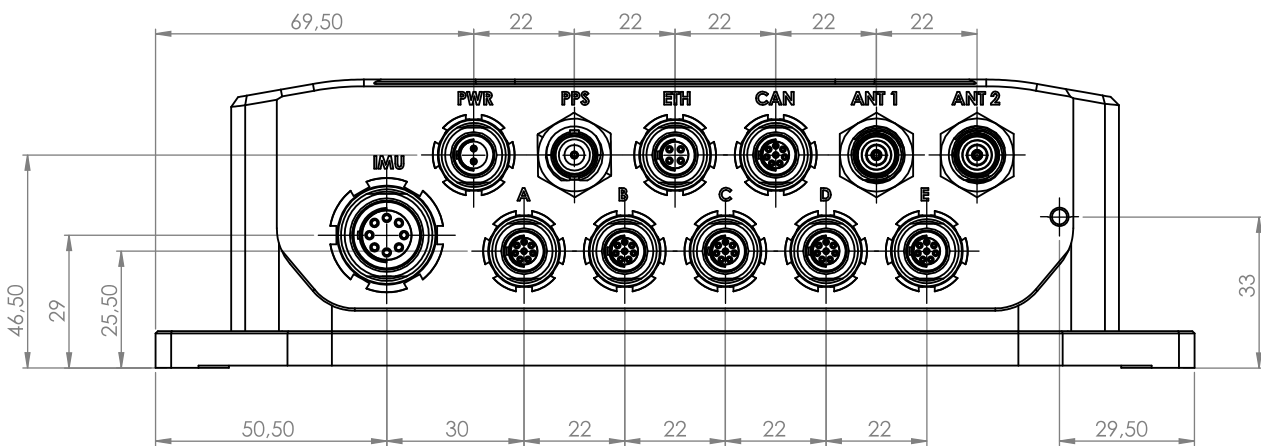

8.7. Processing unit - Rack enclosure

8.7.1. Top view

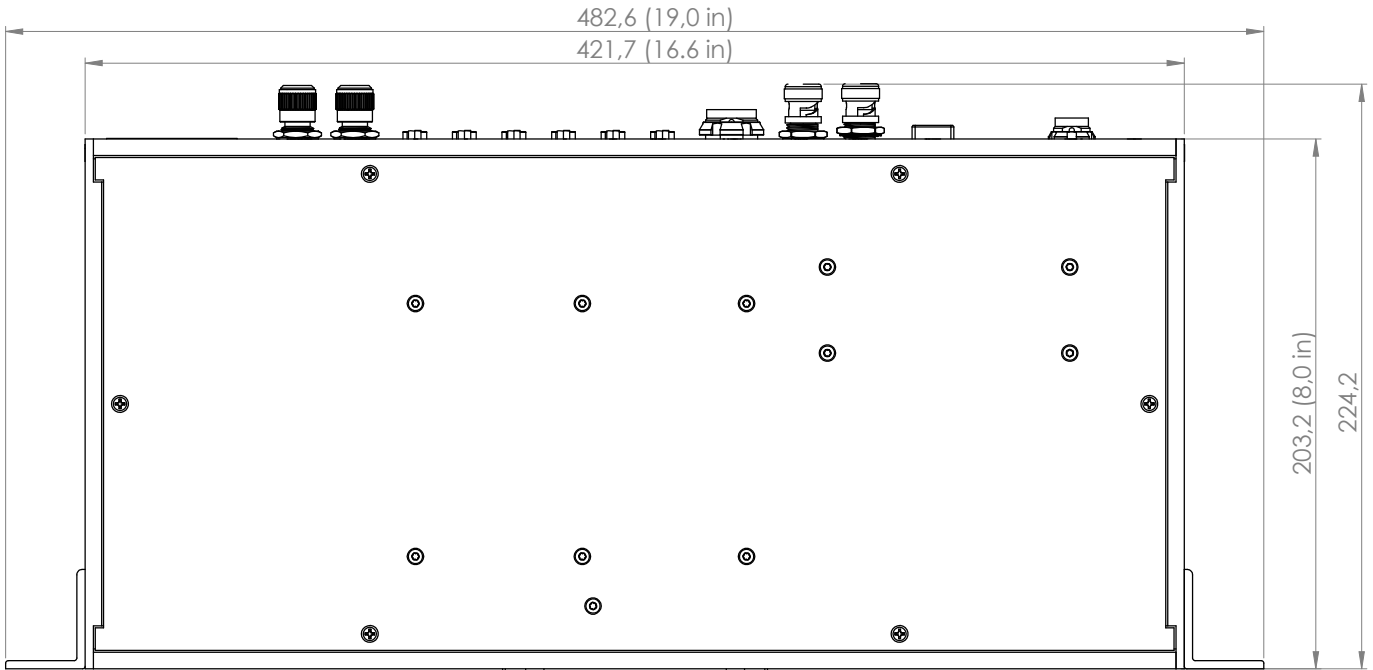

8.7.2. Front view

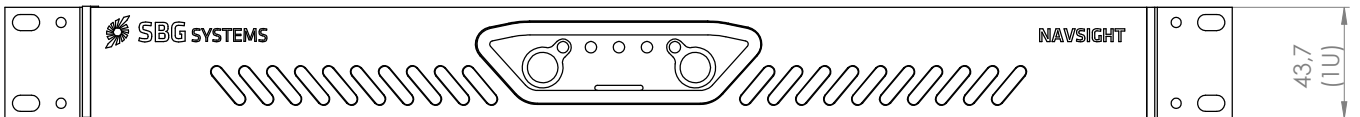

8.7.3. Back view

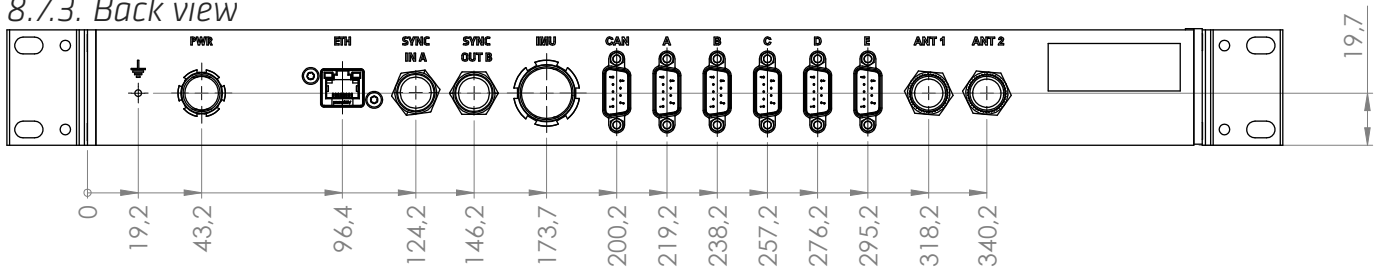

9. Appendix C: Products labels

SBG Systems manufacturing process is based on EN-9100 system with individual and full traceability of every component and operation. Each device is identified by a unique serial number which is used to trace all operations during the product lifetime such as manufacturing, calibration, tests and repairs.

In addition to a unique serial number, a “Hardware Code” and associated hardware revision are used to identify the exact hardware model.

Finally, the “Part Number” is used for logistics purpose. It identifies uniquely the full product configuration, including hardware type, software options, and any software or process customization.

You can find on then side of your Apogee a laser printed labels that hold the Hardware Code as well as Serial Number and Hardware Revision. This labels also include a data-matrix code that encodes the device unique serial number.

In addition, the packaging box includes a second label that provides other useful information such as exact part number and installed firmware version.

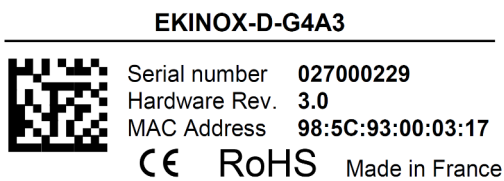

Figure 9.1: Example of INS label

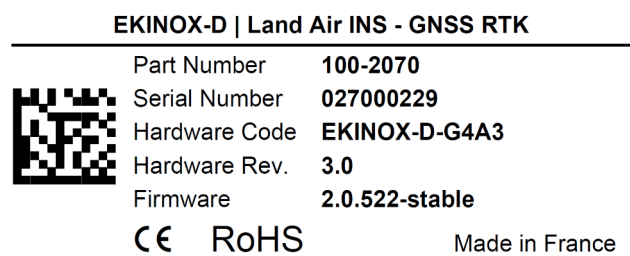

Figure 9.2: Example of packaging label