

EKINOX Series

Tactical Grade MEMS Inertial Sensors

Hardware Manual



Document
Revision
Covers Hardware

EKINOXV3HM.1.2
1.2 - Jun 14, 2022
Ekinox V3 and above

Support

EMEA
support@sbg-systems.com
+33 1 80 88 43 70

Americas
support@sbg-systems.com
+1 (657) 549-5807

Revision history

Rev.	Date	Author	Information
1.3	Jun 14, 2022	Alexis Guinamard	[EK3HM-5] Ekinox hardware manual wrong connector on split cable picture [EK3HM-4] Accessories Update [EK3HM-6] Fixed Ship Motion HP latency to 150s [EK3HM-10] Specify RTK performance according to baseline [EK3HM-12] Update orientation specifications after algorithms update [EK3HM-13] Transferred antennas section to support center [EK3HM-2] Wrong description on automotive connection example
1.1	Sep 25, 2019	Alexis Guinamard	[EK3HM-1] Updated Ordering codes
1	Mar 12, 2019	Alexis Guinamard	First public version

© 2007 – 2022 SBG Systems SAS. All rights reserved. Information in this document is subject to change without notice. Copy or redistribution of this document is forbidden without express authorization of SBG Systems.

Index

Terminology.....	6
1. Introduction.....	7
1.1. Ekinox Overview.....	8
2. Performance specification.....	9
2.1. Inertial measurement unit.....	9
2.1.1. Accelerometers.....	9
2.1.2. Gyroscopes.....	9
2.2. Aiding sensors.....	10
2.2.1. Ekinox D internal GNSS receiver.....	10
2.2.2. External aiding sensors.....	10
2.3. Orientation and Navigation Performance.....	11
2.3.1. Common specifications.....	11
2.3.2. Land applications.....	11
2.3.3. Marine & Subsea applications.....	12
2.3.3.1. Heave performance.....	12
2.3.4. Airborne applications.....	12
2.3.5. Real time Performance monitoring.....	12
3. Mechanical specifications.....	13
3.1. Overview.....	13
3.1.1. Main Specifications.....	13
3.1.2. Device mechanical alignment.....	14
3.1.3. Origin of measurements.....	14
3.1.4. Device label.....	14
3.2. Ekinox A and E mechanical outline.....	15
3.2.1. Top view.....	15
3.2.2. Right view.....	15
3.2.3. Front view.....	16
3.2.4. Bottom view.....	16
3.3. Ekinox D mechanical outline.....	17
3.3.1. Top view.....	17
3.3.2. Right view.....	17
3.3.3. Front view.....	18
3.3.4. Bottom view.....	18
4. Electrical specifications.....	19
4.1. Overview.....	19
4.1.1. Ekinox-A and E with external aiding only.....	19
4.1.2. Ekinox D with dual antenna GNSS.....	19
4.2. Power supply connector.....	20
4.2.1. Connector specifications.....	20

4.2.2. Connector pin out.....	20
4.2.3. Electrical specifications.....	21
4.3. Main connector.....	21
4.3.1. Connector specifications.....	21
4.3.2. Connector pin out.....	22
4.3.3. Electrical specifications.....	23
4.4. Auxiliary connector.....	24
4.4.1. Connector specifications.....	24
4.4.2. Connector pin out.....	24
4.4.3. Electrical specifications.....	25
4.5. GPS antenna connectors.....	26
4.5.1. Electrical specifications.....	26
4.5.2. GPS antenna advice.....	26
4.6. Typical wiring.....	27
4.6.1. Power supply connection.....	27
4.6.2. Main interface connection on RS-232.....	27
4.6.3. Main interface connection on RS-422.....	28
4.6.4. CAN Bus typical wiring.....	28
4.6.5. GNSS connection in RS-232 mode.....	29
4.6.6. Third party aiding equipment connected in RS-422.....	29
4.6.7. Triggering external devices with the sync Out.....	29
4.7. Typical connection topologies.....	30
4.7.1. Ekinox-D in advanced automotive application.....	30
4.7.2. Ekinox-E in marine application.....	31
5. Interfaces specifications.....	32
5.1. Overview.....	32
5.2. Ethernet specifications.....	32
5.2.1. Accessing the Ekinox web page.....	32
5.3. Serial interfaces.....	33
5.4. Supported protocols.....	33
5.5. Synchronization Inputs and outputs.....	33
5.5.1. SYNC In A, B, C, D and E.....	33
5.5.2. SYNC OUT A, B.....	34
5.6. Connections Mapping.....	34
5.6.1. Ekinox-A.....	34
5.6.2. Ekinox-E.....	34
5.6.3. Ekinox-D.....	34
5.7. Internal Datalogger.....	35
5.8. CAN 2.0 A/B interface.....	35
6. Important notices.....	36
6.1. Maintenance.....	36
6.2. Absolute maximum ratings.....	36
6.3. Support.....	37

6.4. Warranty, liability and return procedure.....	37
7. Appendix A: Ordering codes and Accessories.....	38
7.1. Ekinox variants.....	38
7.2. Transport Cases.....	38
7.2.1. CASE-EKI-01.....	38
7.2.2. CASE-AEK-01.....	38
7.3. Associated Software.....	39
7.3.1. Inertial SDK.....	39
7.3.2. SW-QINERTIA-PRO (GNSS/INS Post Processing Software).....	39
7.4. Cables.....	40
7.4.1. CA-AEK-PWR-PSU-1.5M.....	40
7.4.2. CA-AEK-PWR-3M.....	40
7.4.3. CA-AEK-MAIN-ETH-2.5M.....	40
7.4.4. CA-AEK-MAIN-RS232-3M.....	41
7.4.5. CA-AEK-MAIN-RS422-3M.....	42
7.4.6. CA-AEK-AUX-3M.....	43
7.4.7. CA-AEK-SPLIT-MAIN-0.5M.....	44
7.4.8. CA-AEK-SPLIT-MAIN2-0.5M.....	45
7.4.9. CA-AEK-SPLIT-AUX-0.5M.....	46

Terminology

ADC: Analog to Digital Converter
AHRS: Attitude and Heading Reference System
CAN (Bus): Controller Area Network
DHCP: Dynamic Host Configuration Protocol
DVL: Doppler Velocity Log
EKF: Extended Kalman Filter
EEPROM: Electrically-Erasable Programmable Read-Only Memory
FIR: Finite Impulse Response (filter)
FTP: File Transfer Protocol
FS: Full Scale
FOG: Fiber Optic Gyroscope
GNSS: Global Navigation Satellite System
GPS: Global Positioning System
IIR: Infinite Impulse Response (filter)
IMU: Inertial Measurement Unit
INS: Inertial Navigation System
IP: Internet Protocol
LBL: Long Baseline
MAC (address): Media Access Control
MEMS: Micro Electro-Mechanical Systems
NED: North East Down (coordinate frame)
NA: Not applicable
NMEA (NMEA 0183): National Marine Electronics Association (standardized communication protocol)
PPS: Pulse Per Second (signal)
RAM: Random Access Memory
RMA: Return Merchandise Authorization
RMS: Root Mean Square
RTCM: Radio Technical Commission for Maritime Services (Protocol)
RTK: Real Time Kinematics
SI: International System of Units
TBD: To Be Defined
TCP: Transmission Control Protocol
UDP: User Datagram Protocol
UTC: Coordinated Universal Time
USBL: Ultra Short Base Line
VRE: Vibration Rectification Error
WGS84: World Geodetic System 1984
WMM: World Magnetic Model

1. Introduction

Ekinox series is a line of very high performance, MEMS based Inertial Systems which achieve exceptional orientation and navigation performance in a compact and affordable package. It includes a cutting edge Inertial Measurement Unit (IMU) and runs an on-board enhanced Extended Kalman Filter (EKF). The Ekinox line is divided in a comprehensive set of sensors:

- The Ekinox-A version is a Motion Reference Unit (MRU) or Attitude and Heading Reference System (AHRS), providing accurate roll and pitch in dynamic conditions as well as heave, surge and sway outputs. The Ekinox A can be connected to an external GNSS receiver to benefit from absolute heading measurement and improved roll and pitch performance.
- The Ekinox-E and D models are Inertial Navigation Systems (INS), providing both orientation and navigation data even during GNSS outages. Various aiding sensors can be used to provide accurate navigation data in all conditions, but also to improve orientation accuracy:
 - The Ekinox-E model can be connected to external aiding equipment such as two GNSS receivers, 1x DVL or odometer. SBG Systems has developed dedicated “split” cables to simplify the integration with external equipment.
 - The Ekinox-D embeds a dual antenna, survey grade L1/L2 GNSS receiver that supports GPS, GLONASS GALILEO and BEIDOU constellations. It features RTK positioning as well as RAW data support in standard for centimeter precision in real time or post-processing. The dual antenna enables precise heading in low dynamic applications.



Figure 1.1: The Ekinox-E model

To achieve the best performance in every project, specific error models have been implemented to meet applications requirements and to adapt the Ekinox to your vehicle. Sensor configuration is made easy through the modern embedded web interface.

The windows based sbgCenter application also provides a very powerful and easy to use tool to monitor, analyze, record, playback and export all measurements, status and information of your Ekinox.

Finally, the 8 Go embedded data-logger enables seamless post processing work-flow with Qinertia post-processing software for the most demanding applications.

The third generation of Ekinox remains fully compatible with previous Ekinox series.

1.1. Ekinox Overview

The following diagram shows the basic organization of an Ekinox-A, E or D. On the Ekinox-A and E versions, this block diagram is slightly simplified as there is no embedded GNSS.

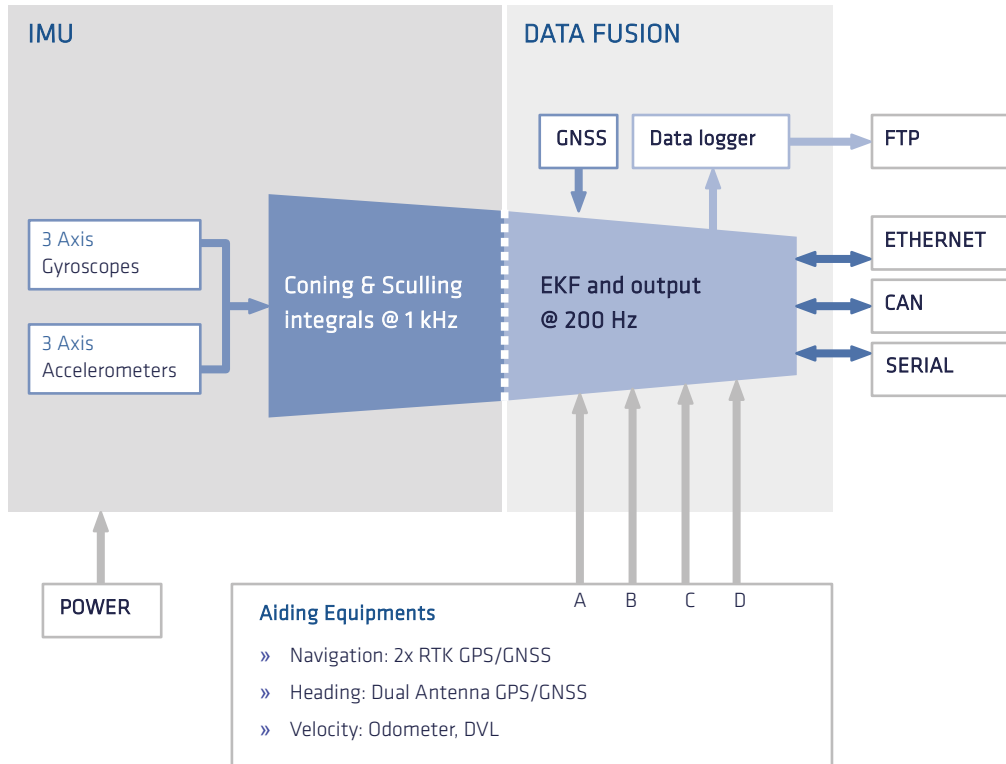

Figure 1.2: Ekinox simplified block diagram

2. Performance specification

2.1. Inertial measurement unit

The IMU is the core component of an inertial navigation system. Leveraging on MEMS technology and an innovative proprietary integration, the Ekinox IMU delivers an exceptional performance while maintaining a reasonable cost.

2.1.1. Accelerometers

The Ekinox IMU contains a set of 3 MEMS capacitive accelerometers. Coupled with advanced filtering techniques and sculling integrals, these accelerometers will provide quartz performance level. Thanks to a very low VRE, the performance is maintained in highly vibrating environments.

	A2	A3	Remarks
Full scale (g)	± 8	± 14	
Velocity Random Walk ($\mu\text{g}/\sqrt{\text{Hz}}$)	7	40	Allan variance - @ 25°C
In run bias instability (μg)	2	10	Allan variance - @ 25°C
Vibration Rectification Error ($\mu\text{g}/\text{g}^2$)	<200	<50	VRE - 20 Hz - 2 kHz
Bandwidth (Hz)	433	433	Attenuation of 3 dB
Orthogonality (°)	< 0.02	< 0.02	Over temperature range

2.1.2. Gyroscopes

The set of 3 high end tactical grade MEMS gyroscopes is sampled at 2.3 kHz. A specific integration design as well advanced signal processing (FIR filters, coning integrals) ensure best performance in vibrating environments.

	G4	Remarks
Full scale (°/s)	± 300	
In run bias instability (°/hr)	0.5	Allan variance - @ 25°C
Angular Random Walk (°/√hr)	0.14	Allan variance - @ 25°C
Bandwidth (Hz)	60	Attenuation of 3 dB
Orthogonality (°)	< 0.02	Over temperature range

2.2. Aiding sensors

Many different aiding sensors can be used to aid the Ekinox INS.

2.2.1. Ekinox D internal GNSS receiver

The EKINOX-D embeds a survey grade GNSS receiver (L1/L2 GPS, GLONASS, GALILEO, BEIDOU), capable of SBAS, DGPS, and RTK positioning. With a refresh rate of 5Hz, this receiver provides best accuracy and reliability in harsh GNSS environments. The standard RAW data output enables highest performance in post-processing applications.

	Specification		Remark
Channels	448		
Signal tracking	GPS: L1, L2, L2C GLONASS: L1, L2 GALILEO: E1 B/C, E5b	Beidou B1, B2, SBAS, QZSS	All constellations & signals enabled by default
Horizontal position accuracy	Single point L1/L2	1.2 m	RTK precision available in option
	SBAS / DGPS	0.6 m / 0.4 m	
	RTK	1 cm + 1ppm	
Velocity accuracy	0.03 m/s RMS		
True Heading Accuracy	0.15°	1m baseline	
	0.1°	2m baseline	
Velocity limit	515 m/s		Due to export licenses
Time to First Fix	Cold start	< 45 s	
	Hot start	< 20s	
Signal reacquisition			1s
Output frequency	5 Hz		
Diff. Corrections	RTCM V2.x, V3.x CMR V2.0, CMR+		Sent via serial PORT C
Options	RTK		



Note: All these specifications reflect the intrinsic GNSS receiver accuracy. Please refer to section 2.3 Orientation and Navigation Performance for complete Ekinox accuracy specifications.

2.2.2. External aiding sensors

The Ekinox-A accepts a single external GNSS receiver connection to improve orientation performance. It can be a dual antenna receiver for precise heading output.

The Ekinox-E and D models accept up to two external GNSS receivers to provide navigation data and improve orientation performance. In addition, a DVL or an odometer can be connected on Ekinox-E/D as velocity aiding inputs.

2.3. Orientation and Navigation Performance

All specifications are rated to 1σ , over -40°C to $+75^{\circ}\text{C}$ unless otherwise stated.

These specifications have been obtained by field tests, using typical mission scenarios and comparison to reference units using post-processing. Outage performance validated by simulation of repeated, pure GNSS outages, separated by at least 200s of optimal GNSS condition, compared to a reference RTK trajectory.

Performance parameters may be affected in multi-path and poor GNSS reception environments such as Urban canyons.

For each application, we present the specified accuracy for the following positioning modes:

- **SP:** Single Point mode and is the default L1 GPS fix quality
- **RTK:** Real Time Kinematics with a typical 1 cm accuracy position
- **PP:** Post Processed data using Qinertia

2.3.1. Common specifications

	Performance	Remarks
Measurement range	360° in all axes, no mounting limitation	Solid state sensors
Orientation noise	< 0.02° RMS	Static

2.3.2. Land applications

All specifications are valid with DMI (odometer) aiding for typical land mapping trajectories.

Outage Duration	Positioning Mode	Position Accuracy		Velocity Accuracy		Attitude Accuracy	
		Horizontal	Vertical	Horizontal	Vertical	Roll/pitch	Heading
0 s	SP	1.20 m	1.2 m	0.05 m/s	0.05 m/s	0.02°	0.05°
	RTK	0.01 m + 1ppm	0.02 m + 1ppm	0.02 m/s	0.02 m/s	0.015°	0.04°
	PP	0.01 m + 1ppm	0.02 m + 1ppm	0.01 m/s	0.01 m/s	0.01°	0.03°
10 s	SP	1.5 m	1.4 m	0.05 m/s	0.05 m/s	0.03°	0.06°
	RTK	0.15 m	0.1 m	0.03 m/s	0.03 m/s	0.02°	0.05°
	PP	0.03 m	0.03 m	0.015 m/s	0.01 m/s	0.015°	0.03°
60 s / 1km	SP	4 m	2.5 m	0.1 m/s	0.1 m/s	0.08°	0.15°
	RTK	3 m	0.75 m	0.1 m/s	0.1 m/s	0.08°	0.12°
	PP	0.4 m	0.1 m	0.03 m/s	0.02 m/s	0.03°	0.05°

2.3.3. Marine & Subsea applications

All specifications are valid with dual antenna aiding for typical marine survey trajectories.

Outage Duration	Positioning Mode	Position Accuracy		Velocity Accuracy		Attitude Accuracy	
		Horizontal	Vertical	Horizontal	Vertical	Roll / Pitch	Heading
0 s	SP	1.20 m	2.0m	0.05 m/s	0.05 m/s	0.02°	0.03° (baseline > 2m)
	RTK	0.01 m + 1ppm	0.02m + 1ppm	0.02 m/s	0.02 m/s	0.015°	0.02° (baseline > 4m)
	PP	0.01 m + 1ppm	0.02 m + 1ppm	0.01 m/s	0.01 m/s	0.01°	0.02°
10 s	SP	2.2 m	2.5m	0.1 m/s	0.05 m/s	0.05°	0.06° (baseline > 2m)
	RTK	0.3 m	0.1m	0.05m/s	0.03 m/s	0.05°	0.05° (baseline > 4m)
	PP	0.05 m	0.03 m	0.02 m/s	0.01 m/s	0.02°	0.03°
30 s	SP	4.0m	2.5 m	0.3m/s	0.15 m/s	0.1°	0.15° (baseline > 2m)
	RTK	3.0 m	0.75 m	0.25 m/s	0.1 m/s	0.1°	0.13° (baseline > 4m)
	PP	1.0 m	0.3 m	0.05 m/s	0.03 m/s	0.04°	0.05°

2.3.3.1. Heave performance

	Real Time Heave	Delayed Heave (ShipMotionHP)	Remark
Range	50 meters	50 meters	Automatic adjustment to every sea conditions
Period	0 to 20 s	0 to 40 s	
Accuracy	5 cm or 5%	2 cm or 2.5 %	Whichever is greater; Velocity aided heave
Mode	Real time, auto tuning	Fixed 150s delay	On board computation

2.3.4. Airborne applications

Specifications evaluated with a dual antenna heading source.

Positioning Mode	Position Accuracy		Velocity Accuracy		Attitude Accuracy	
	Horizontal	Vertical	Horizontal	Vertical	Roll	Heading
SP	1.20 m	2.0m	0.05 m/s	0.05 m/s	0.02°	0.03° (baseline > 2m)
RTK	0.01m + 1ppm	0.02m + 1ppm	0.02 m/s	0.02 m/s	0.015°	0.02° (baseline > 4m)
PP	0.01 m + 1ppm	0.02 m + 1ppm	0.01 m/s	0.01 m/s	0.01°	0.02°

2.3.5. Real time Performance monitoring

The Extended Kalman filter provides feedback about its performance. The following validity levels thresholds are defined for the Ekinox series

	Threshold	Comments
Attitude Valid	0.3° / 0.07°	AHRS / Normal INS mode
Heading Valid	0.5° / 0.2°	AHRS / Normal INS mode
Velocity Valid	0.2m/s	Total velocity error (3D)
Position Valid	1m	Total position error (3D)



Note: The thresholds are less accurate in AHRS mode, when there is no GNSS aiding available. Full performance can be reached with GNSS aiding.

3. Mechanical specifications

3.1. Overview

The Ekinox enclosure is composed of two anodized aluminum parts, one for the cover and one for the base plate. The device uses high quality alloys and connectors to offer a full IP-68 enclosure and a good resistance to harsh environments.

The cover part is made of 6061 aluminum alloy for its resistance to both seawater and industrial chemical environments. In addition, this material offers a nice visual aspect.

The base plate is made of 7075 aluminum alloy to ensure best durability and accuracy. Indeed, this alloy offers an incredible mechanical strength to guarantee the base plate integrity and accuracy during device installation.

The cover and base plates are sealed together by four M3 stainless steel A4 screws (3016L). The Ekinox should be installed to the host interface using four M4 stainless steel A4 screws.

The Ekinox connectors are high quality Fischer connectors that offers IP-68 protection even unconnected. The Ekinox-D also include TNC connectors to plug the GPS antennas.



Warning: The Ekinox surface model is not designed for prolonged operation in salt water environments. Check section Maintenance for more details about operation in sea water environments.

3.1.1. Main Specifications

The table below summarizes all mechanical and environmental specifications.

Mechanical Specifications

	A / E	D
Height	5.8 cm (2,28")	7.5 cm (2.9")
Width	10 cm (3,94")	10 cm (3,94")
Depth	8.6 cm (3,39")	8.6 cm (3,39")
Weight	435 g (1.0 lb)	610 g (1.3 lb)
Shocks	500 g for 0.3 ms	
Operating Vibrations	3g RMS – 20Hz to 2 kHz as per MIL-STD-810G (A2 range options) 8g RMS – 20Hz to 2 kHz as per MIL-STD-810G (A3 range options)	

Environmental Specifications

Enclosure	Anodized Aluminum
IP rating	IP-68 (24 hours at 2 meters)
Operating temperature	-40 to 75°C (-40 to 167°F)
Storage	-40 to 85°C (-40 to 185°F)
Humidity	Sealed, no limit
MTBF (computed)	50.000 hours
Calibration interval	None required, maintenance free

3.1.2. Device mechanical alignment

For best measurement accuracy, a good mechanical alignment is required. During manufacturing, the Ekinox measurement frame has been carefully aligned to 0.02° with the base plate for roll, pitch and yaw angles.

To ease the yaw alignment (X axis), the base plate features two alignment holes Ø 4 mm H8 that guarantees with two taper pins Ø 4 mm h7 a yaw alignment better than ±0.04°.

 **Note:** The base plate is the same for the Ekinox A, E and D models.

3.1.3. Origin of measurements

The Ekinox offers the possibility to output data at different measurement points.

The default center of measurement is located on top of Ekinox enclosure, on the coordinate frame center drawing. It is represented on the mechanical outlines by the  symbol. This point is defined to simplify installation.

Alternatively, user can select between two other center of measurement points:

- Alignment hole (aligned to the bottom of the base plate)
- Bare IMU center of measurement, represented by the  symbol.

3.1.4. Device label

SBG Systems manufacturing process is based on EN-9100 system with individual and full traceability of every component and operation. Each Ekinox is identified by a unique serial number that can be used to trace all operations during the product lifetime such as manufacturing, calibration, tests and repairs.

In addition to a unique serial number, a product code is used to define exactly the device type and options.

You can find on the back side of the Ekinox a laser printed label that hold all these identification information. This label also includes a data-matrix code that encodes the device unique serial number.

In addition, the Ekinox packaging includes a second label that provides other useful information such as installed firmware version or GNSS options in the case of an Ekinox-D.

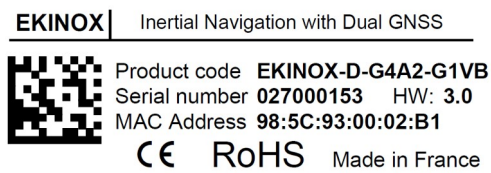

Figure 3.1: Ekinox device label sample

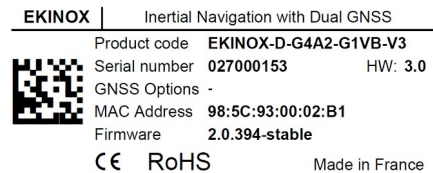
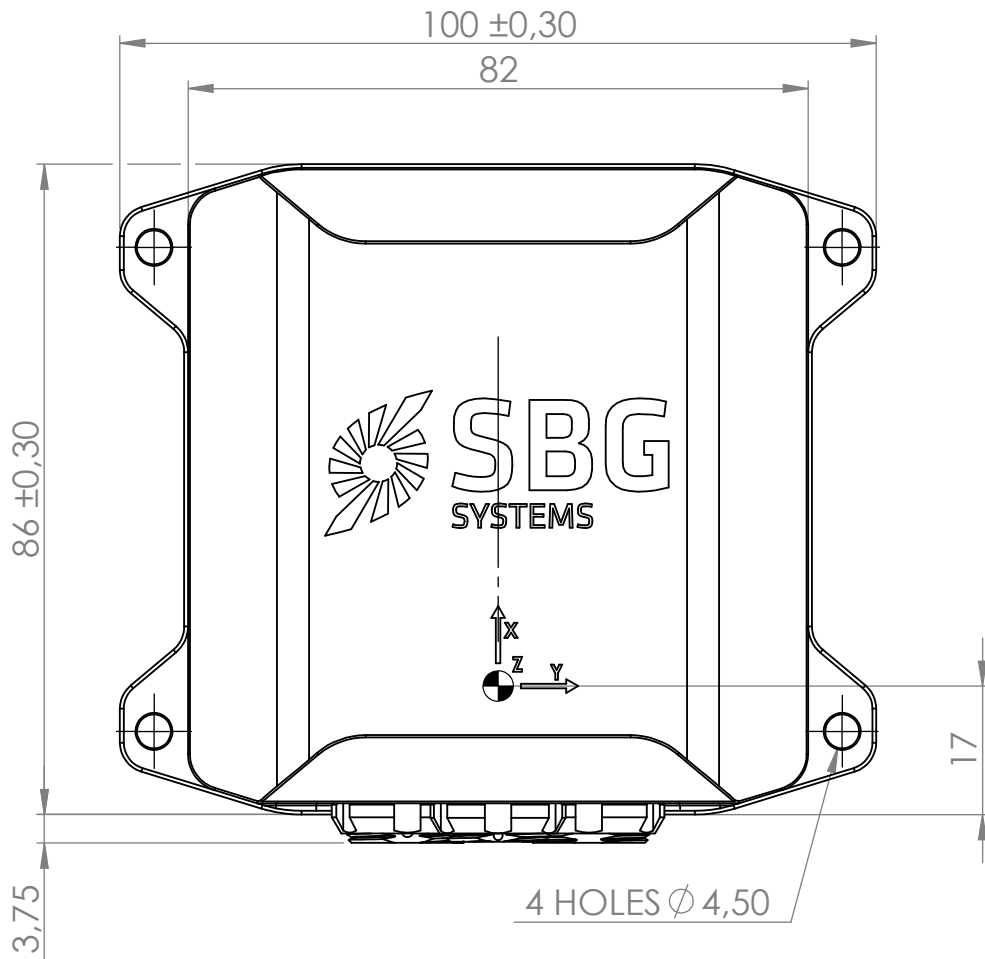

Figure 3.2: Ekinox packaging label sample

3.2. Ekinox A and E mechanical outline

All dimensions are in mm.

3.2.1. Top view



3.2.2. Right view

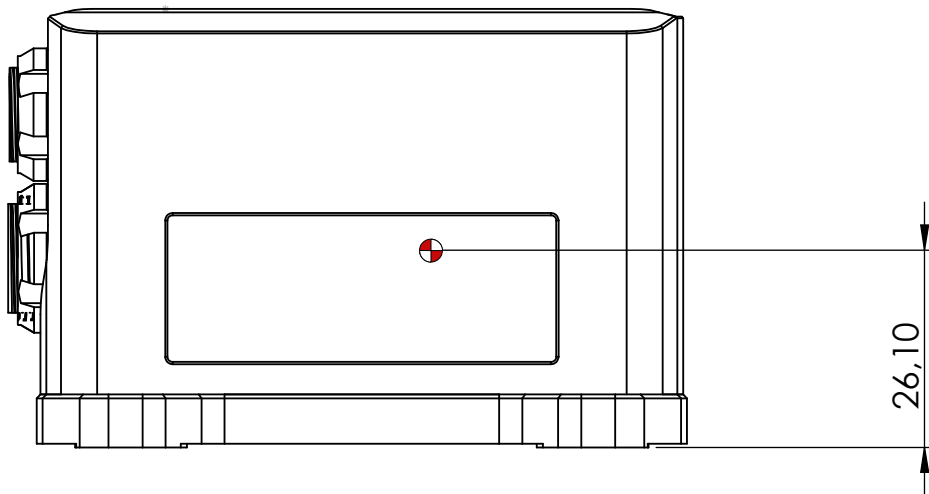

3.2.3. Front view

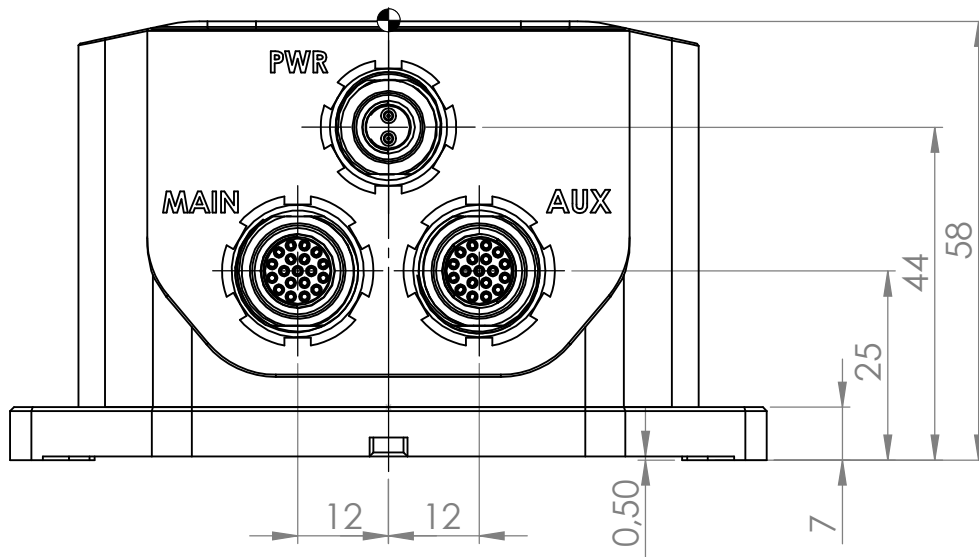

3.2.4. Bottom view

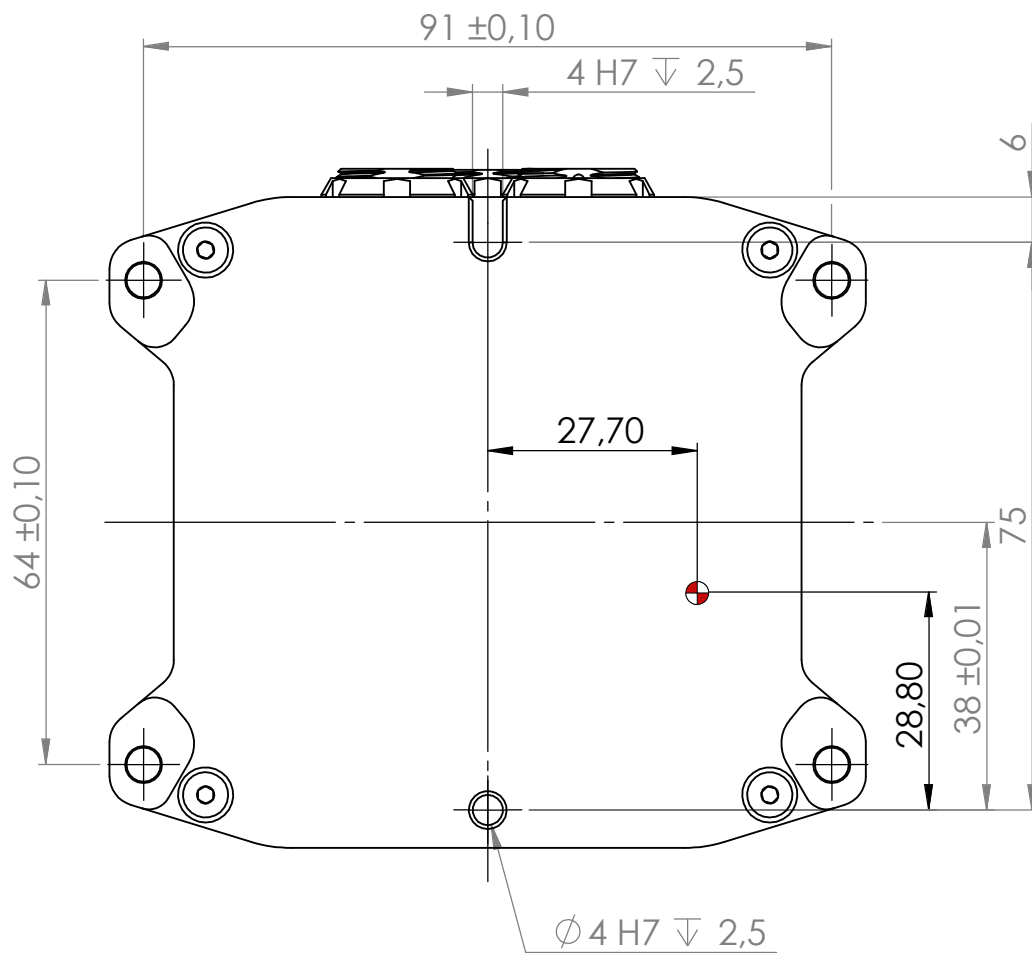

3.3. Ekinox D mechanical outline

All dimensions are in mm.

3.3.1. Top view

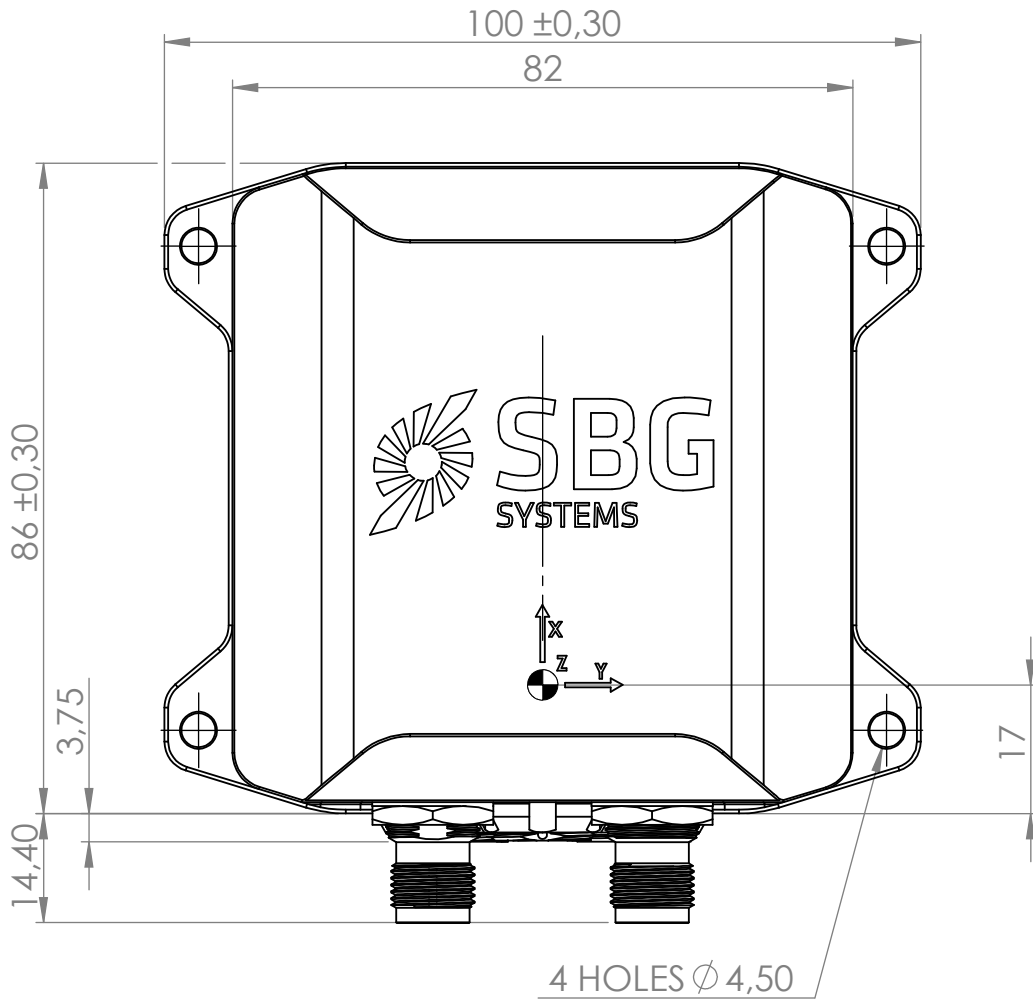

3.3.2. Right view

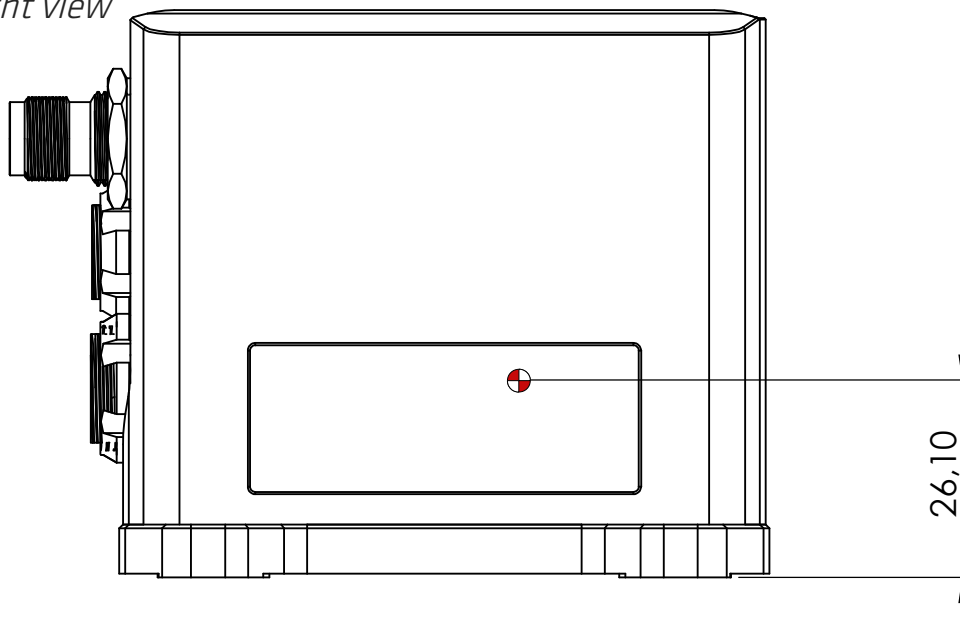

3.3.3. Front view

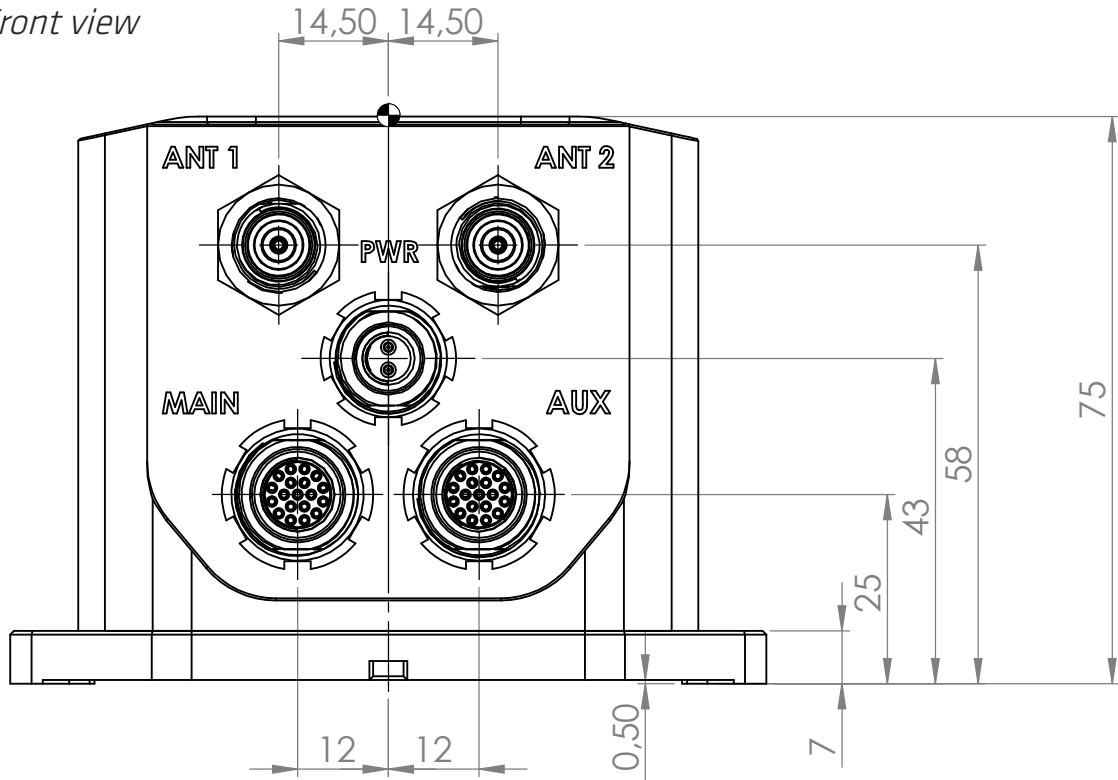

3.3.4. Bottom view

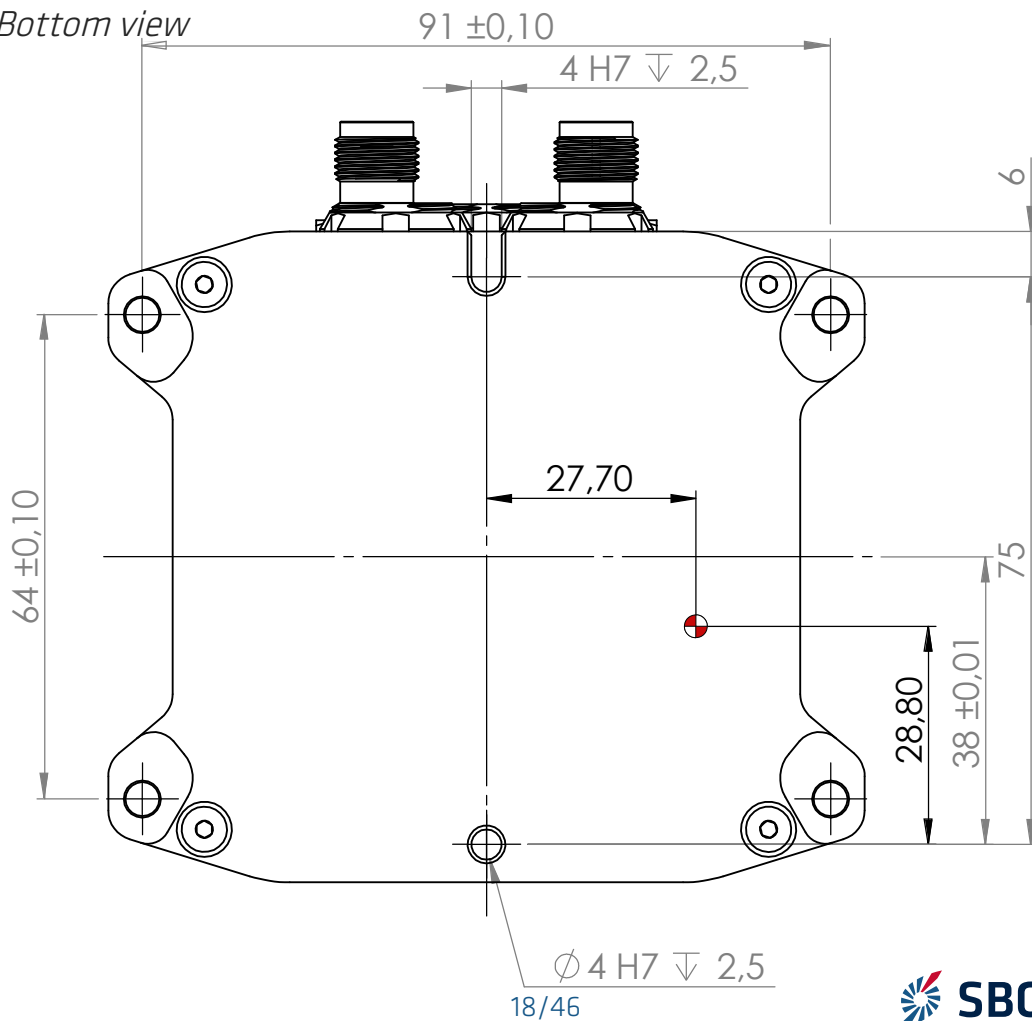

4. Electrical specifications

4.1. Overview

The Ekinox connectors are all placed on the front panel. The connectors are referenced and identified by laser marking on the enclosure. Each connector is different and fool proofed using a specific keying to avoid any misconnection.

SBG Systems has selected high quality connectors designed for harsh environments. They offer an IP-68 protection when the plug is properly mounted.

4.1.1. Ekinox-A and E with external aiding only



Figure 4.1: Ekinox AHRs or INS with external aiding

Ekinox-A and E share the same form factor.

4.1.2. Ekinox D with dual antenna GNSS



Figure 4.2: Ekinox INS with integrated GNSS receiver

4.2. Power supply connector

The Ekinox can be powered by a DC voltage from 9 to 36 Volts. For best robustness and to reduce power consumption, the internal power module is a high efficiency isolated DC/DC converter.

Apply a constant power supply to VIN+ and VIN- pins. The shield is directly connected to the device mechanical enclosure. It should not be used as the ground return signal.

4.2.1. Connector specifications

The power supply uses a 2 ways male AluLite Fischer connector which is compatible with the Fischer Core Series. The exact receptacle reference is: AL1731-DBPU-103-Z051PB11-12G13

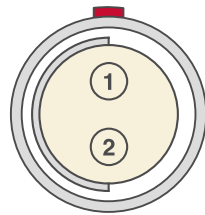

Figure 4.3: Power receptacle front view



Figure 4.4: Power plug top view

This size 103 connector mates with the following plugs references in AluLite or Core Series. Alternative plugs can be found if required (eg short plug). Don't forget that these two references don't include the cable clamp sets.

- AL1731-S-103-Z051SR11-11 (AluLite version)
- S-103-Z051-130 (Core Series version)



Note: Although Fischer connectors are IP68 and specified to operate from -40°C to +75°C, the plug should be connected at temperatures above -20°C and in a dry environment.



Warning: The power receptacle uses male connectors for obvious security reasons. Please make sure that you order the correct plug reference.

4.2.2. Connector pin out

Pin #	Name	Description
Shield	Shield	Connected to mechanical ground
1	VIN+	Connected to the power supply
2	VIN-	Connected to the electrical ground

4.2.3. Electrical specifications

Recommended electrical specifications from -40°C to 75°C.

Parameter	Min.	Typ.	Max.	Units	Conditions
Operating voltage	9		36	VDC	
Power consumption	-----	3	-----	W	Ekinox-A / E
	-----	5	-----	W	Ekinox-D
Allowable Input Voltage Ripple			400	mV p-p	
Under voltage lock out	-----	8,5	-----	V	Turn on threshold
	-----	7,5	-----	V	Turn off threshold
Galvanic Isolation			200	VDC	VIN+ to Mechanical Ground VIN- to Mechanical Ground

4.3. Main connector

The main connector is mainly used to configure the device and read data from it. It features the following interfaces:

- One serial interface that supports full-duplex operations at up to 921 600 bps. It can be configured to operate as an RS-232 or RS-422 interface by pulling down the pin 2.
- One CAN 2.0A/B interface that supports up to 1 Mbit/s data rate used to output data.
- One Ethernet 100BASE-T interface for device configuration, FTP access and virtual UDP or TCP/IP serial ports.
- One synchronization input / event marker signal for clock synchronization or to output data on a signal event.
- Two Synchronization output signals for time stamping and to trigger some equipment.

4.3.1. Connector specifications

The main connector uses a 19 ways female AluLite Fischer connector which is compatible with the Fischer Core Series. To avoid misconnection the main connector uses the keying code 11. The exact receptacle reference is: AL1731-DBPU-104-A092PB11-12G13



Figure 4.5: Main receptacle front view



Figure 4.6: Main plug

This 104 size connector mates with following Core Series and AluLite plugs: Don't forget that these two references don't include the cable clamp sets. Other compatible references, with possibly right angle design can be found.

- AL1731-S-104-A092SR11-11 (AluLite version)

- S-104-A092-130 (Core Series version)

4.3.2. Connector pin out

Connector's pin out is sorted by function rather than pin numbering.

Pin #	Name	Description
Shield	Shield	Connected to the mechanical ground
1	GND	Connected to the main connector electrical ground
5	GND	Connected to the main connector electrical ground
7	GND	Connected to the main connector electrical ground
2	RS-232/RS-422	Pull to GND to select RS-422 mode
3	Sync Out A	Synchronization output signal A
4	Sync Out B	Synchronization output signal B
6	Sync In A	Synchronization input signal A
8	Port A – RS-422 - Rx+	Port A serial input data / configuration RS-422
9	Port A – RS-422 - Rx-	Port A serial input data / configuration RS-422
10	Port A – RS-422 - Tx-	Port A serial output data / configuration RS-422
11	Port A – RS-422 - Tx+	Port A serial output data / configuration RS-422
12	Port A – RS-232 - Rx	Port A serial input data / configuration RS-232
13	Port A – RS-232 - Tx	Port A serial output data / configuration RS-232
14	CAN H	CAN bus 2.0 high line
15	CAN L	CAN bus 2.0 low line
16	Ethernet Tx+	White/Green RJ45 pin#1
17	Ethernet Tx-	Green RJ45 pin#2
18	Ethernet Rx-	Orange RJ45 pin# 6
19	Ethernet Rx+	White/Orange RJ45 pin# 3



Note: By default, if you leave the RS-232/RS-422 signal unconnected, the Port A will operate in RS-232 mode.

4.3.3. Electrical specifications

Recommended electrical specifications from -40°C to 75°C.

All signals are referenced to GND_MAIN. Pins #3, #4 and #7 are internally connected.

Parameter	Conditions	Min.	Typ.	Max.	Units
RS-232/RS-422 selector pin					
Input Voltage Range		-25		+25	V
Input Threshold	Threshold Low	0,8	1,5		V
	Threshold High		1,8	2,7	V
Internal Pull-Up Resistor	Pull Voltage = +5VDC		1		kΩ
Sync Out A, Sync Out B					
Output Type		Push pull			-
High-level output Voltage	I < 30mA	3.5	5.0		V
Low-level output Voltage	I < 30mA		0.0	1.5	V
Port A – RS-422 – Receiver					
Input Resistance	Common mode voltage [-7V – 12V]	96			kΩ
Input Differential Threshold	Common mode voltage [-7V – 12V]	-200		-50	mV
Input Hysteresis			30		mV
Port A – RS-422 – Transmitter					
Differential Output Voltage		2			V
Common-Mode Output Voltage				3	V
Port A – RS-232 – Receiver, Sync In A					
Input Voltage Range		-25		+25	V
Input Threshold	Threshold Low	0,8			V
	Threshold High			2,7	V
Input Resistance		3	5	7	kΩ
Port A – RS-232 – Transmitter					
Output Voltage Swing	Tx loaded with 3kΩ to GND_MAIN	±5	±5,4		V
CAN					
Recessive Bus Voltage		2		3	V
CAN H Output Voltage	Dominant	3,0		4,25	V
CAN L Output Voltage	Dominant	0,5		1,75	V
Differential Input Voltage	-12V ≤ Common Mode Voltage ≤ +12V	0,5	0,7	0,9	V

4.4. Auxiliary connector

The external aiding connector is mainly used to connect aiding equipment to the Ekinox. It features the following connections:

- Up to two RS-232 or RS-422 ports that support full-duplex operations
- Two Rx only RS-232 or RS-422 ports
- Four synchronization input signals

4.4.1. Connector specifications

The external connector uses a 19 ways female AluLite Fischer connector which is compatible with the Fischer Core Series. To avoid misconnection the external connector uses the keying code 12. The exact receptacle reference is: AL1731-DBPU-104-A092PB12-12G13



Figure 4.7: External receptacle front view



Figure 4.8: External plug

This 104 size connector mates the following core series and AluLite versions connectors. Other compatible references, with possibly right angle design can be found.

- AL1731-S-104-A092SR12-11 (AluLite version)
- S-104-A092-230 (Core Series version)

4.4.2. Connector pin out

Connector's pin out is sorted by function rather than pin numbering.

Pin #	Name	Description
Shield	Shield	Connected to the mechanical ground
1	GND	Connected to the external connector electrical ground
5	GND	Connected to the external connector electrical ground
7	GND	Connected to the external connector electrical ground
4	Sync In B	Port B input synchronization
12	Port B – RS-232/RS-422 – Rx+	Port B serial input RS-232/RS-422
13	Port B – RS-422 – Rx-	Port B serial input RS-422
14	Port B – RS-422 – Tx+	Port B serial output RS-422
15	Port B – RS-232/RS-422 – Tx-	Port B serial output RS-232/RS-422
6	Sync In C	Port C input synchronization
16	Port C – RS-232/RS-422 – Rx+	Port C serial input RS-232/RS-422
17	Port C – RS-422 – Rx-	Port C serial input RS-422

Pin #	Name	Description
18	Port C – RS-232/RS-422 – Tx-	Port C serial output RS-232/RS-422
19	Port C – RS-422 – Tx+	Port C serial output RS-422
2	Sync In D	Port D input synchronization
8	Port D – RS-232/RS-422 – Rx+	Port D serial input RS-232/RS-422
9	Port D – RS-422 – Rx-	Port D serial input RS-422
3	Sync In E	Port E input synchronization / Odometer B
10	Port E – RS-422 – Rx-	Port E serial input RS-422
11	Port E – RS-232/RS-422 – Rx+	Port E serial input RS-232/RS-422 / Odometer A



For Ekinox-D, if the internal GNSS receiver is enabled, the PORT B will not be available as it is used internally by the GNSS receiver. However, the Sync In B signal will still be available.

4.4.3. Electrical specifications

Recommended electrical specifications from -40°C to 75°C.

Parameter	Conditions	Min.	Typ.	Max.	Units
Sync In pins, RS-232 Receivers					
Input Voltage Range		-25		+25	V
Input Threshold	Threshold Low	0,6	1,2		V
	Threshold High		1,5	2,4	V
Input Resistance		3	5	7	kΩ
RS-232 Transmitters					
Output Voltage Swing	Tx loaded with 3kΩ to GND_AUX	±5	±5,4		V
RS-422 Receivers					
Input Resistance	Common mode voltage [-7V - 12V]	48			kΩ
Input Differential Threshold	Common mode voltage [-7V - 12V]	-200		-50	mV
Input Hysteresis			30		mV
Port B, C, D, E – RS-422 – Transmitter					
Differential Output Voltage		2			V
Common-Mode Output Voltage				3	V

4.5. GPS antenna connectors

To connect external GPS antennas, the Ekinox-D versions feature two TNC connectors that provide IP-68 protection even unmated. The internal GNSS receiver only supports active GPS antennas.



Figure 4.10: GPS antenna connector



Figure 4.9: Typical TNC antenna cable

Any standard coax cable with a TNC male connector can be used with the Ekinox. However, care should be taken to select a high quality coaxial cable with low loss in case of long cable.

Please be advise that the Ekinox doesn't implement any lightning protection. The GPS antenna and cable are very sensitive to strikes and a proper installation with lightning protection devices may be required.



Note: For best performance, the antenna(s) should be connected before the power is applied. The Ekinox GPS estimates the noise floor of the antenna during the startup sequence.



Warning: With the Ekinox-D, for correct dual antenna operations, please use the exact same TNC cables and antennas for the primary and secondary GPS.

4.5.1. Electrical specifications

Parameter	Specifications	Remarks
LNA supply voltage	5 VDC	±5%
LNA supply current	< 100 mA	



Note: If you use an amplified antenna splitter or special GNSS antennas such as a Trimble Zephyr 2, please make sure that the actual gain at the Ekinox side isn't above 50 dB.

4.5.2. GPS antenna advice

The Ekinox-D embeds a high performance GNSS receiver that supports GPS L1/L2, GLONASS L1/L2, BEIDOU B1/B2 and GALILEO E1/E5b signals.

For optimal performance, SBG Systems recommends the use of a multi-constellation GNSS antenna. In addition, a dual frequency (L1/L2) tracking is mandatory for Ekinox-D dual antenna heading operation. Don't forget to also check the GPS antenna LNA power requirements such as input voltage (must accepts 5 VDC) and input current (must be below 70 mA).

SBG Systems has selected some high quality GPS antennas for different applications. Please refer to the section 7.4.9 to get more details on available antennas.



Note: As a rule of thumb, true heading and/or RTK measurements require high quality GNSS antennas to achieve the stated accuracy.

4.6. Typical wiring

In this section, we briefly describe a few recommended wiring diagrams.

4.6.1. Power supply connection

Concerning power supply, we recommend shielded cable, with at least AWG 24 wires.

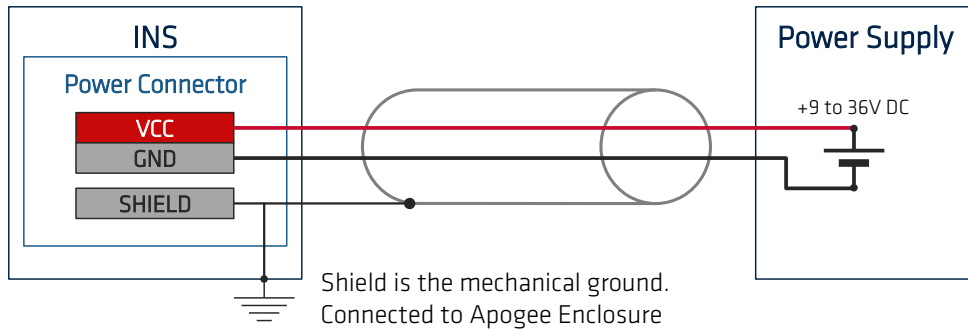

Figure 4.11: Power supply wiring connections

4.6.2. Main interface connection on RS-232

Below is shown the main interface (Port A) connection, using a full duplex RS-232 connection. The recommended cable is a shielded AWG26 cable.

A protocol selector pin is left open in RS-232 mode.

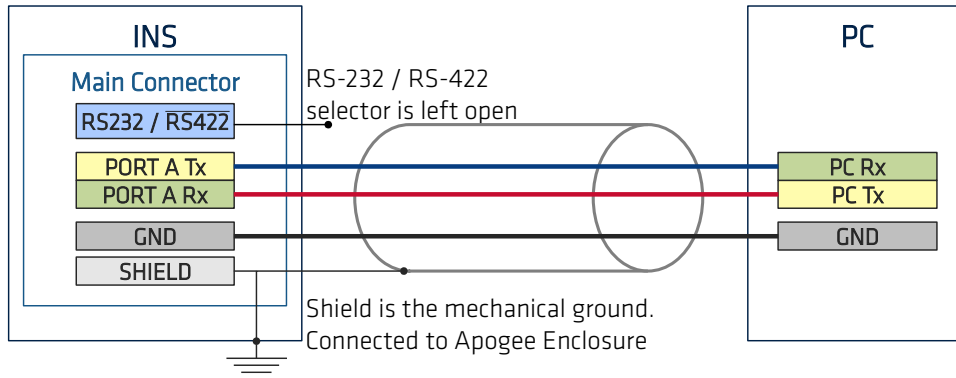

Figure 4.12: Main serial interface full duplex connection in RS-232

4.6.3. Main interface connection on RS-422

Below is shown the main interface (Port A) connection, using a full duplex RS-422 connection. The recommended cable is a shielded twisted pairs AWG26 cable.

Note the termination resistors (Usually 120 ohms) that can optionally be placed on receiver side to avoid communication errors in long distance communications. These resistors can be omitted in short distance communications in order to reduce power consumption.

A protocol selector pin is connected to GND in RS-422 mode.

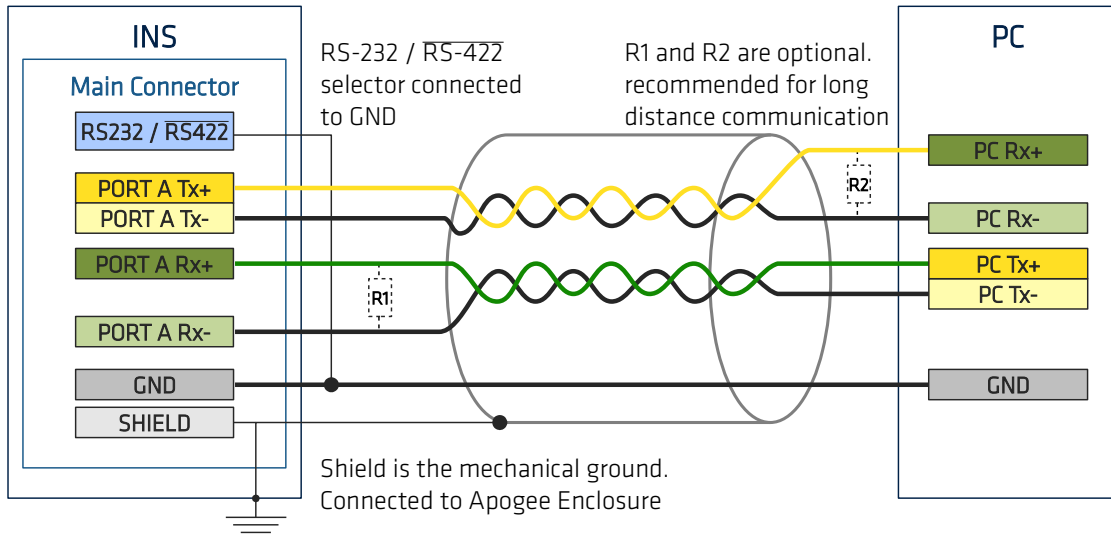

Figure 4.13: Main serial interface full duplex connection in RS-422 mode

4.6.4. CAN Bus typical wiring

CAN bus is designed to operate with low cost twisted pairs cables. The bus may be terminated by a single 60 ohm resistor, or multiple resistors on each bus ends (as long as the equivalent parallel impedance is 60 ohm). This resistor is not present in the Ekinox.

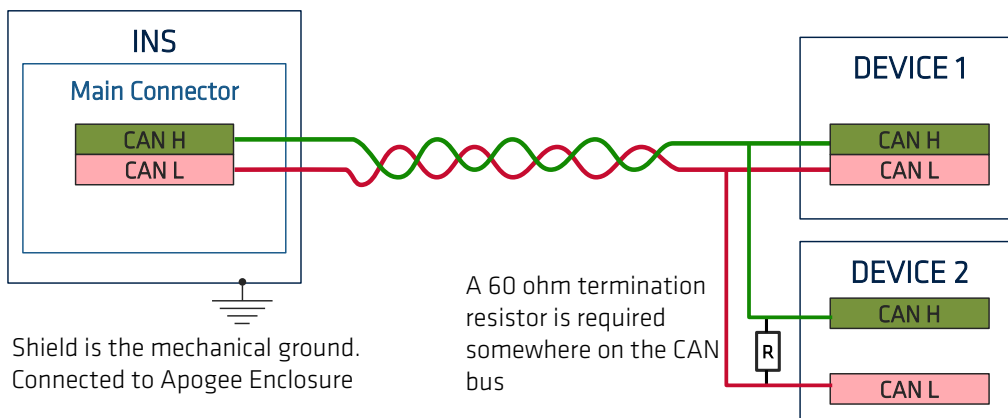

Figure 4.14: Basic CAN bus wiring

4.6.5. GNSS connection in RS-232 mode

For this typical connection, a shielded AWG 26 cable should be used. Depending on PPS signal strength, we do not recommend this cable to measure more than a few meters. For long distance, PPS signal and GPS NMEA signals should be separated in two cables for better noise immunity.

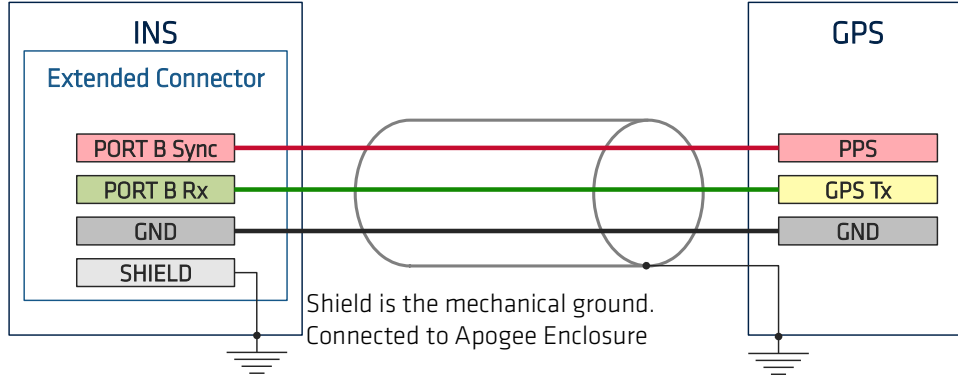

Figure 4.15: Typical wiring diagram for Ekinox with external GNSS receiver

4.6.6. Third party aiding equipment connected in RS-422

For this connection, we recommend shielded twisted pairs AWG26 cable. As for main communication interface, a termination resistor may be required depending on the communication distance.

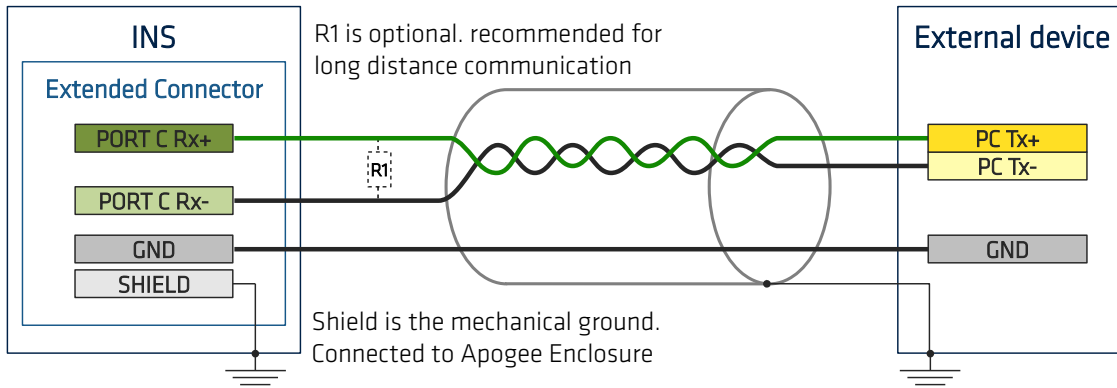

Figure 4.16: Third party aiding equipment with RS-422 interface

4.6.7. Triggering external devices with the sync Out

Consider a camera that must take a picture when an event is provided on Event Out pin. Event Out and Sync Out are “open drain” outputs, which means a pull up resistor must be used on receiver side, as shown on the diagram.

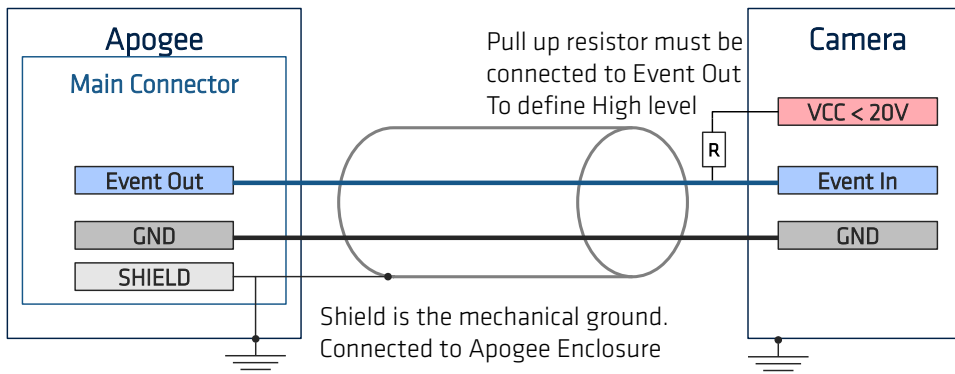

Figure 4.17: Sync Out connection with pull up resistor

4.7. Typical connection topologies

The following use cases are presented to quickly show how to connect the Ekinox to various external materials in different applications.

4.7.1. Ekinox-D in advanced automotive application

Here we present an advanced use case where the Ekinox-D sensor is used in a land survey application. The Ekinox configuration is the following:

- On the aiding/input side:
 - Two GNSS antennas are connected for GNSS true heading measurement
 - RTCM data coming from a RTK base station is connected to PORT D to provide RTK accuracy to internal GPS.
 - An odometer is connected to PORT E to provide velocity aiding in harsh GPS environments.
 - Finally an event input is triggered by user at several instants. For example, this helps locating physical objects within the recorded data.
- On the output side:
 - Sync Out pulse is configured as 10Hz output to trig a camera 10 times per second.
 - Data output is stored on a PC through ETH 0 interface. A new log is sent for each captured picture.

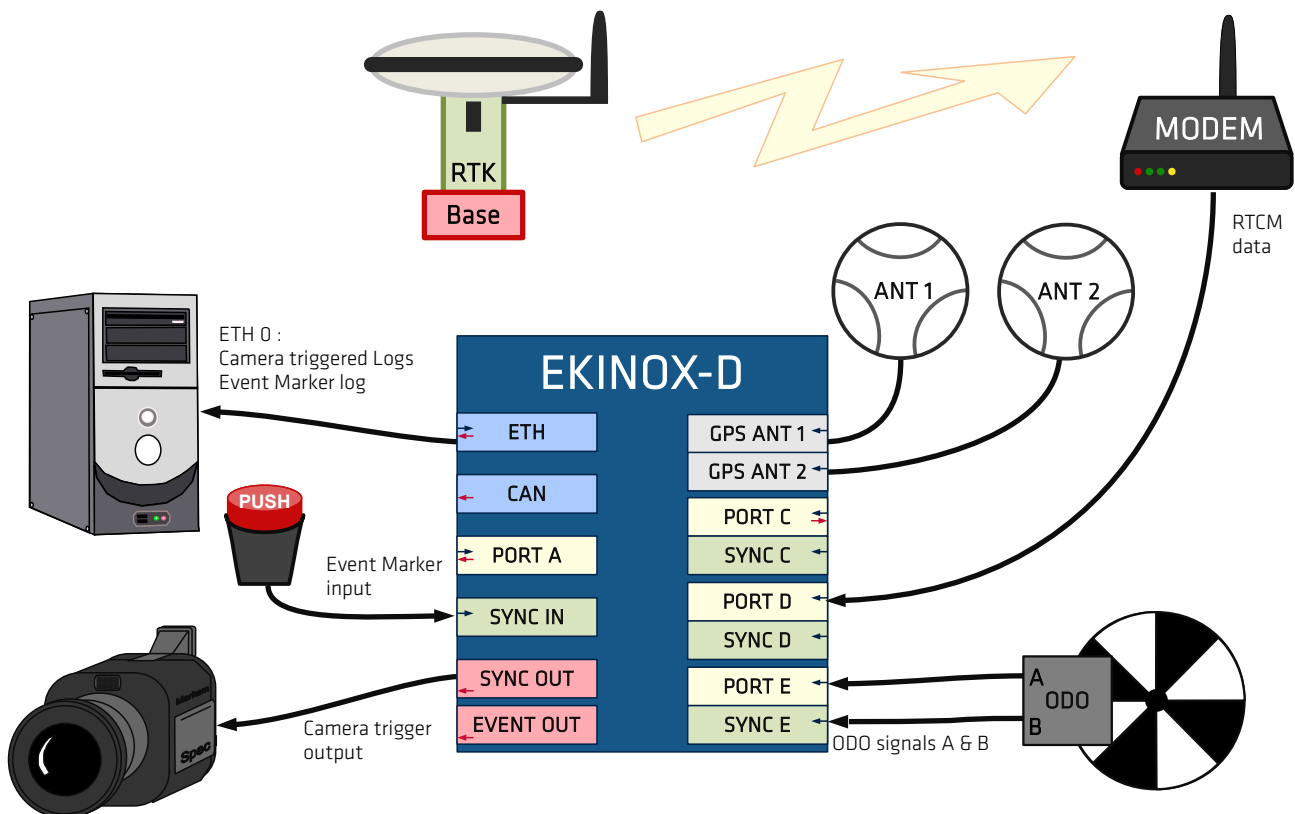

Figure 4.18: Ekinox-D connection in an advanced automotive application

4.7.2. Ekinox-E in marine application

In the next application example, the Ekinox is used for both vessel display and monitoring, as well as ship motion sensor for several third party equipment.

Connections are made easy using Ethernet interface when available with external devices.

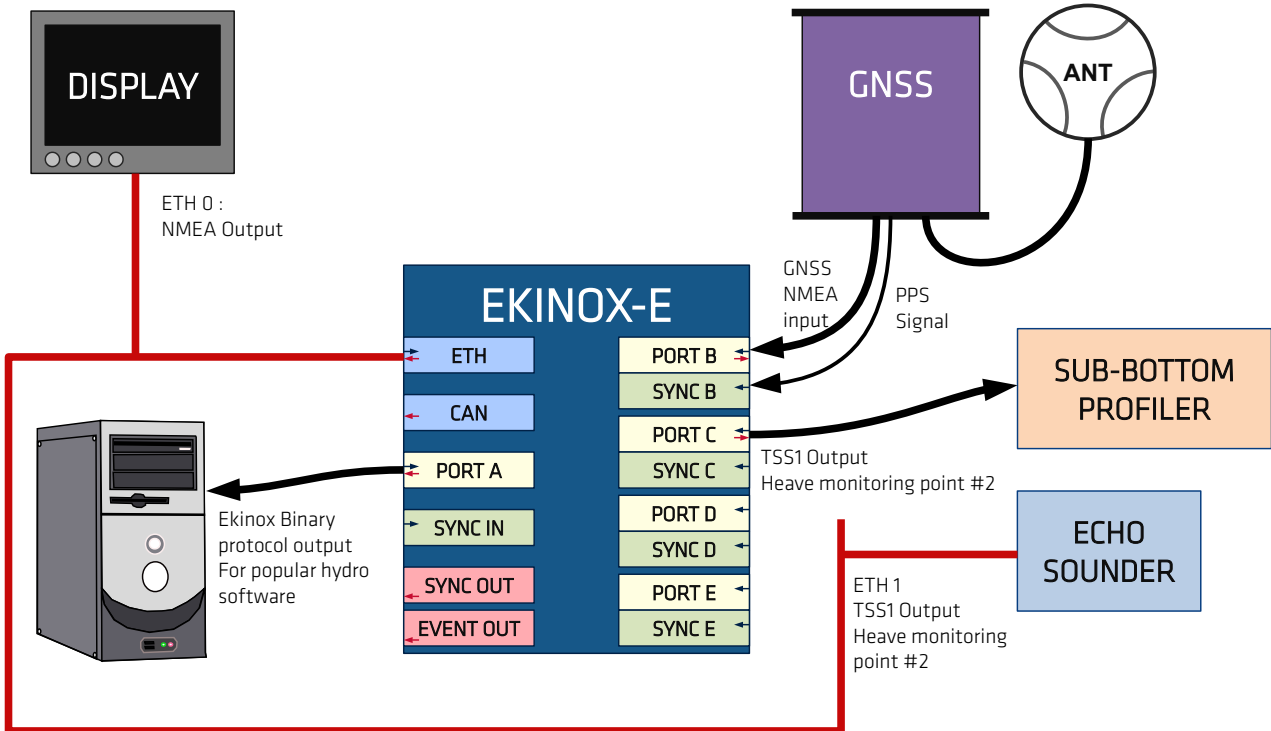

Figure 4.19: Ekinox-E use in advanced Marine application

5. Interfaces specifications

5.1. Overview

The Ekinox features the following interfaces:

- An Ethernet Interface
- 1 to 5 Physical RS-232/RS-422 serial ports (Port A to Port E).
- Internal data logger
- CAN bus
- 2x SYNC Outputs and 5x SYNC Inputs

5.2. Ethernet specifications

The Ekinox main port features an Ethernet 100BASE-T interface. This interface is used for the device installation and configuration through an embedded web page.

This Ethernet interface is a key feature of the Ekinox device as it provides the following services:

- A Bonjour service used to easily discover any connected Ekinox and get its IP address
- An embedded web interface used to configure the device and visualize output data
- An FTP access to download logs recorded in the internal Flash memory
- Five virtual serial ports Eth0 to Eth4 that support either UDP or TCP/IP protocols

5.2.1. Accessing the Ekinox web page

Thanks to the ZeroConf technology, you can easily access the web page using the Ekinox serial number. Indeed, the Ekinox broadcast a web service so you can connect to the configuration web page using the following address:

http://ekinox_02700001.local

Where 02700001 is the device serial number. It can be found on a label located on the enclosure's right side.

If your web browser supports DNS Service Discovery such as Safari, you should directly see a link to all Ekinox devices available on the network.



Browser Compatibility: SBG Systems recommend using latest version of Chrome, Safari or FireFox web browser. Due to Internet Explorer limitations, only versions 9 and above are supported.

5.3. Serial interfaces

Physical serial interfaces are designated as Port A, B, C, D and E and have the following common characteristics:

- 4 800 to 921 600bps operation (Default set to 115 200)
- RS-232 or RS-422 modes, configured by software
- Parity control enabling/disabling (disabled by default)
- Data bits: 8
- Stop bits: 1

The following table provides more details about each port specificity in terms of availability, and capabilities:

Port	Availability	Tx / Rx availability	RS-232/422 configuration Cable / software defined	sbgECom binary commands input	Other functions / multiplexing
A	All	Tx/Rx	Cable	Yes	
B	EKINOX A / E	Tx/Rx	Software	-	
C	All	Tx/Rx	Software	-	
D	All	Rx	Software	-	
E	All	Rx	Software	-	Multiplexed w. Odometer input



Note: The Ekinox automatically limits the serial signals slew-rate to minimize EMI and reduce communication error when the baud rate is below 230 400 bps.

5.4. Supported protocols

The Ekinox has been designed to be connected to a large range of aiding equipment and materials. In addition to the native sbgECom binary protocol, other third party or standard protocols are also supported such as NMEA, RTCM, TSS1, Septentrio SBF, Novatel Binary protocol, Trimble and others:



Note: For a complete description of the sbgECom and other supported protocols, please refer to the Ekinox and Apogee Firmware Reference Manual.

5.5. Synchronization Inputs and outputs

The Ekinox series integrate a set of Sync Inputs and outputs. These logic pins can have different functions:

5.5.1. SYNC In A, B, C, D and E

- Output log trigger: All pulses received generate events that can generate specific Logs output. Any output log can be triggered by an event pulse. The Ekinox can handle up to 200Hz triggers.
- Event Marker: Events up to 1kHz are supported on each pin.
- PPS input
- External aiding data time-stamping

5.5.2. SYNC OUT A, B

These output pins can be used for two functions:

- Main loop divider: This event is activated at the sensor sample time, but its frequency is divided by the output divider. If the divider is set to 4, pulse output frequency will be 200Hz / 4 = 50Hz.
- PPS: This output will also be synchronized with the sample time, but it will be provided at 1Hz only when clock is correctly estimated. So this output is provided at each top of a second in UTC time.

5.6. Connections Mapping

You will find below the available connections configuration for aiding inputs. The Ekinox-A, E and D share roughly the same mapping but there are some specificities due to the embedded GNSS receiver present in the model D.

5.6.1. Ekinox-A

	Port A	Port B	Port C	Port D	Port E	Eth 0	Eth 1-4
Binary commands	•					•	
GNSS 1 input	•	•	•	•			•
Data output	•	•	•			•	•

5.6.2. Ekinox-E

	Port A	Port B	Port C	Port D	Port E	Eth 0	Eth 1-4
Binary commands	•					•	
GNSS 1 input	•	•	•	•			•
GNSS 2 input	•	•	•	•	•		•
Odometer input					•		
DVL input	•	•	•	•	•		•
Data output	•	•	•			•	•

5.6.3. Ekinox-D

	Port A	Port C	Port D	Port E	Eth 0	Eth 1-4
Binary commands	•				•	
GNSS 2 input	•	•	•	•		•
Odometer input				•		
RTCM input	•	•	•	•	•	•
DVL input	•	•	•	•		•
Data output	•	•			•	•



Note 1: Please remember that the Port B is not available for the Ekinox-D version when the internal GNSS is enabled.

5.7. Internal Datalogger

The Ekinox includes an internal datalogger capable of storing all data at 200Hz for 48 hours. The internal datalogger is composed of a high speed memory buffer and an 8 GB flash storage. To allow high bandwidth and to reduce power consumption, the memory buffer is saved to the flash storage ten times per second.

5.8. CAN 2.0 A/B interface

The main port contains a CAN 2.0 A/B interface that supports transfer rate at up to 1 Mbits/s. This CAN interface is mainly used to output log messages. By default, the CAN interface is disabled.

The CAN bus implementation and especially timing settings complies with the CAN in Automation (CiA) DS-102 standard.

The Ekinox supports the following standard CAN bus bitrates:

- 1 000 kBit/s
- 500 kBit/s
- 250 kBit/s
- 125 kBit/s
- 100 kBit/s
- 50 kBit/s
- 20 kBit/s
- 10 kBit/s



Note: The Ekinox does not include any termination resistor, and it belongs to user to ensure that the CAN bus includes termination resistors in order to get proper communications.

6. Important notices

6.1. Maintenance

The Ekinox does not require particular maintenance when operated in normal conditions. Nevertheless, if you would like to maintain your sensor performance to the highest level, SBG Systems can provide a maintenance service with regularly planned checkups and calibrations.

When used in harsh environments, please use damp clothes to clean the surface of the Enclosure.

Although not recommended, it is possible to use the Ekinox in salt water environments. In such environments, the Ekinox enclosure must be rinsed with clear water to remove any long term presence of salt on the enclosure.

6.2. Absolute maximum ratings

Stresses above those listed under the Absolute Maximum Ratings may cause permanent damage to the device. This is a stress rating only; functional operation of the device at these or any other conditions above those indicated in the operational section of this specification is not implied. Exposure to absolute maximum rating conditions for extended periods may affect device reliability.

Parameter	Rating
VDD - GND	+/- 36 V
Galvanic isolation: Power supply connector to chassis ground Main connector GND to chassis ground Extended connector to chassis ground	+/- 200 V
Rx+, Rx-, Logic inputs pins input voltage to signal GND	±25 V
Sync Out max current	30mA Short circuit protected
Logic output Max current	150 mA
CANH, CANL	±80 V
Shock	500 g for 0.3 ms
Operating temperature range	-40 to 75°C (-40 to 167°F)
Storage temperature range	-40 to 85°C (-40 to 185°F)

Table 1: Absolute maximum ratings

6.3. Support

Our goal is to provide the best experience to our customers. If you have any question, comment or problem with the use of your product, we would be glad to help you, so feel free to contact us: support@sbg-systems.com

6.4. Warranty, liability and return procedure

SBG Systems provides a warranty covering this product against any defect in materials or manufacture for a period of two (2) years from the date of shipment. In the event that such a defect becomes obvious during the stipulated warranty period, SBG Systems will undertake, at its sole discretion, either to repair the defective product, bearing the cost of all parts and labor, or to replace it with an identical product.

In order to avail itself of this warranty, Customer must notify SBG Systems of the defect before expiry of the warranty period and take all steps necessary to enable SBG Systems to proceed. Upon reception of required information (Sensor serial number, defect description), SBG Systems will issue an RMA and will provide return instructions. Customer shall be responsible for the packaging and the shipment of the defective product to the repair center notified by SBG Systems, the cost of such shipment being borne by Customer.

This warranty shall not be construed as covering defects, malfunctions or damages caused by improper use or inadequate maintenance of the product. Under no circumstances shall SBG Systems be due to provide repair or replacement under this warranty in order a) to repair damage caused by work done by any person not representing SBG Systems for the installation, repair or maintenance of the product; b) to repair damage caused by improper use or connection to incompatible equipment, and specifically, the opening of the housing of the equipment under warranty shall cause the warranty to be automatically canceled.

This warranty covers the product hereunder and is provided by SBG Systems in place of all and any other warranty whether expressed or implied. SBG Systems does not guarantee the suitability of the product under warranty for sale or any specific use.

SBG Systems' liability is limited to the repair or replacement of defective products, this being the sole remedy open to Customer in the event the warranty becomes applicable. SBG Systems cannot be held liable for indirect, special, subsequent or consequential damage, irrespective of whether SBG Systems has or has not received prior notification of the risk of occurrence of such damage.

7. Appendix A: Ordering codes and Accessories

7.1. Ekinox variants

The following Ekinox variants are available to order. Please contact your sales representative for more information.

Navsight Variant

EKINOX-A | Land Air AHR5

EKINOX-A | Marine MRU

EKINOX-E | Land Air INS

EKINOX-E | Marine INS

EKINOX-D | Land Air INS - GNSS

EKINOX-D | Land Air INS - GNSS RTK

EKINOX-D | Marine INS - GNSS

EKINOX-D | Marine INS - GNSS RTK

7.2. Transport Cases

7.2.1. CASE-EKI-01

This small transport case can be used to securely ship or stock:

- An Ekinox A or E
- A GPS antenna ref ANT-ACM-G5ANT-3AMT1
- One or two cables for power supply and Ethernet connection.



Figure 71 : 9.2.1. CASE-EKI-01

7.2.2. CASE-AEK-01

This larger transport case can be used to securely ship or stock:

- An Ekinox A, E or D
- Up to two survey grade GNSS antennas
- Many cables or third party devices



Figure 72 : 9.2.2. CASE-AEK-01

7.3. Associated Software

7.3.1. Inertial SDK

The SBG Systems Inertial SDK is very helpful to configure, playback recorded logs, export data to text files or third party software and even develop custom code for the Ekinox.

It contains the following items:

- sbgCenter analysis software
- sbgECom C library and examples

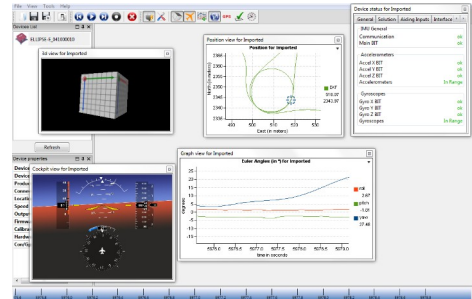

Figure 7.3: sbgCenter analysis tool

The Inertial SDK can be downloaded on the SBG Systems support center.

7.3.2. SW-QINERTIA-PRO (GNSS/INS Post Processing Software)

Qinertia is a 100% in-house post-processing software solution. This full-featured software enhances SBG Systems inertial navigation systems performance by post processing inertial data with raw GNSS observable in both forward and backward directions.

Key Features:

- Tight Coupling INS/GNSS fusion
- Achieve highest possible accuracy
- + 7,000 Base Stations always up-to-date
- Open to all Industry Standards
- Fastest Processing available on the market
- Modern & Intuitive Interface

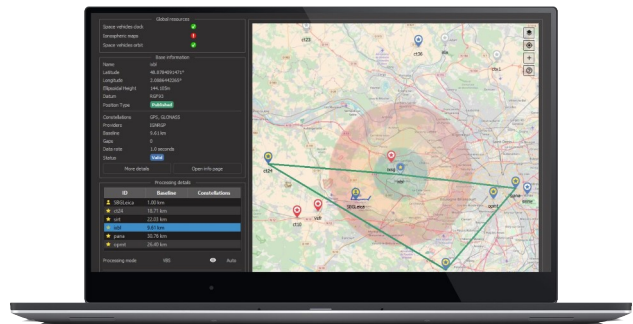

7.4. Cables

7.4.1. CA-AEK-PWR-PSU-1.5M

This cable is an international AC/DC adapter to power up the Ekinox or the SplitBox.

- 110 / 250 V input with UK, US and EU plugs.
- 12V output
- No IP rating

7.4.2. CA-AEK-PWR-3M

This cable mates with the POWER connector to power up the Ekinox or the SplitBox from external power supply.

- 1 x Fischer Core Series S-103-Z051-130 connector
- 1 x open end
- IP-68 rating
- 3m long AWG 18 cable
- Weight: 170g

Cable wiring is:

Pin	Signal	Color
SHIELD	NC	SHIELD
1	V+	Red
2	V-	Black

7.4.3. CA-AEK-MAIN-ETH-2.5M

This cable provides easy Ethernet access to the Ekinox.

- 1 x Fischer Core Series S-104-A092-130.
- 1 x RJ-45 connector for Ethernet connection.
- No IP rating.
- 2.5 m cable (CAT5 type)
- Weight: 90g

Cable wiring is:

Pin on Fisher connector	Signal	Color
SHIELD	SHIELD	SHIELD
16	ETHERNET_TXD+	Green / White
17	ETHERNET_TXD-	Green
18	ETHERNET_RXD-	Orange
19	ETHERNET_RXD+	Orange/ White

Unspecified pins or colors are not connected internally.



Figure 7.4 : AC / DC power adapter



Figure 7.5 : Alternative Power cable



Figure 7.6 : Ethernet cable

7.4.4. CA-AEK-MAIN-RS232-3M

This cable is designed to mate with the MAIN connector and provides RS-232 communication with PORT A as well as other MAIN connector pins access.

- 1 x Fischer Core Series S-104-A092-130
- 1 open end
- IP-68 rating
- 3 m AWG26 shielded cable with twisted pairs
- Weight: 300g

Cable wiring is:

Pin on Fisher connector	Signal	Color
SHIELD	SHIELD	SHIELD
1	GND	Grey
2	RS422/232 PORT A	
3	SYNC OUT A	Pink
4	SYNC OUT B	Purple
5	GND	Black
6	SYNC IN A	Light blue
7	GND	Light green
8	PORTA_422_RX+	
9	PORTA_422_RX-	
10	PORTA_422_TX-	
11	PORTA_422_TX+	
12	PORTA_232_RX	Grey / White
13	PORTA_232_TX	Grey / Red
14	CAN_H	Brown / White
15	CAN_L	Brown
16	ETHERNET_TXD+	Dark green / White
17	ETHERNET_TXD-	Dark green
18	ETHERNET_RXD-	Orange
19	ETHERNET_RXD+	Orange / White

Unspecified pins or colors are not connected internally.



Figure 7.7 : Main RS-232 cable

7.4.5. CA-AEK-MAIN-RS422-3M

This cable is designed to mate with the MAIN connector and provides RS-422 communication with PORT A as well as other MAIN connector pins access.

- 1 x Fischer Core Series S-104-A092-130
- 1 open end
- IP-68 rating
- 3 m AWG26 shielded cable with twisted pairs
- Weight: 300g

Cable wiring is:

Pin on Fisher connector	Signal	Color
SHIELD	SHIELD	SHIELD
1	GND	Grey
2	RS422/232 PORT A	- Internally connected to pin 1 -
3	SYNC OUT A	Pink
4	SYNC OUT B	Purple
5	GND	Black
6	SYNC IN A	Light blue
7	GND	Light green
8	PORTA_422_RX+	White
9	PORTA_422_RX-	Red
10	PORTA_422_TX-	Dark blue
11	PORTA_422_TX+	Dark blue / White
12	PORTA_232_RX	
13	PORTA_232_TX	
14	CAN_H	Brown / White
15	CAN_L	Brown
16	ETHERNET_TXD+	Dark green / White
17	ETHERNET_TXD-	Dark green
18	ETHERNET_RXD-	Orange
19	ETHERNET_RXD+	Orange / White

Unspecified pins or colors are not connected internally.



Figure 7.8 : Main RS-422 cable

7.4.6. CA-AEK-AUX-3M

This cable is designed to mate with the AUX connector and provides access to all AUX connector pins.

- 1 x Fischer Core Series S-104-A092-230
- 1 open end
- IP-68 rating
- 3 m AWG26 shielded cable with twisted pairs
- Weight: 300g

Cable wiring is:

Pin	Signal	Color
SHIELD	SHIELD	SHIELD
1	GND	Grey
2	Sync In D	Yellow
3	Sync In E	Pink
4	Sync In B	Purple
5	GND	Grey / Red
6	Sync In C	Light blue
7	GND	Grey / White
8	Port D – RS-232/RS-422 – Rx+	White
9	Port D – RS-422 – Rx-	Red
10	Port E – RS-422 – Rx-	Dark blue
11	Port E – RS-232/RS-422 – Rx+	Dark blue / White
12	Port B – RS-232/RS-422 – Rx+	Light green
13	Port B – RS-422 – Rx-	Black
14	Port B – RS-422 – Tx+	Brown / White
15	Port B – RS-232/RS-422 – Tx-	Brown
16	Port C – RS-232/RS-422 – Rx+	Dark green / White
17	Port C – RS-422 – Rx-	Dark green
18	Port C – RS-232/RS-422 – Tx-	Orange
19	Port C – RS-422 – Tx+	Orange / White

Unspecified pins or colors are not connected internally.



Figure 7.9 : Auxiliary cable

7.4.7. CA-AEK-SPLIT-MAIN-0.5M

This cable provides a robust and easy access to all interfaces available on the EKINOX MAIN connector using standard plugs.

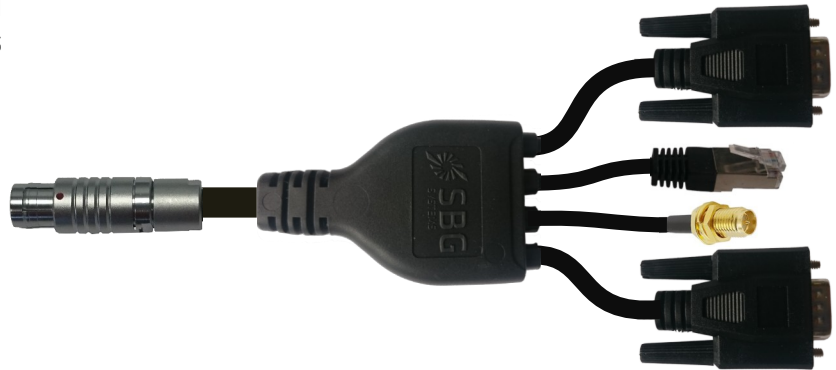

Figure 7.10: CA-AEK-SPLIT-MAIN-0.5M – Lengths not to scale

The cable has following characteristics:

- 1 x Fischer Core Series S-104-A092-130 that connects on MAIN connector
- 1x DB-9 for PORT A in RS-232 mode, full duplex
- 1x RJ-45 plug for Ethernet connection
- 1x Female DB-9 plug for CAN bus output
- 1x Male SMA plug for Sync IN A (External GNSS PPS connection)
- Total length: 50cm (25cm before / after cable splitter)

Connectors pin-outs are defined below:

Pin on DB-9 "PORT A"	Function	Pin on DB-9 "CAN"	Function	Pin on RJ45 ETH	Function
2	PORT A RX	2	CAN L	1	Tx+
3	PORT A TX	3	GND	2	Tx-
4	SYNC OUT A	7	CAN H	3	Rx+
5	GND			6	Rx-

Pin on SMA "SYNC IN A"	Function
Central pin	SYNC IN A
Outer	GND

7.4.8. CA-AEK-SPLIT-MAIN2-0.5M

This cable provides a robust and easy access to all interfaces available on the EKINOX MAIN connector using standard plugs.

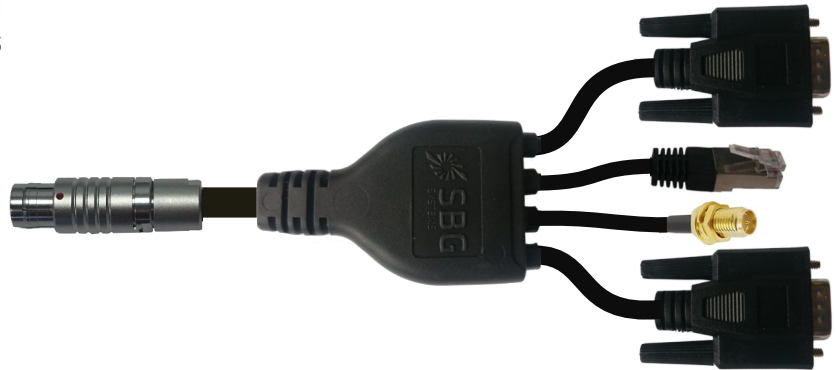

Figure 7.11: CA-AEK-SPLIT-MAIN2-0.5M – Lengths not to scale

The cable has following characteristics:

- 1x Fischer Core Series S-104-A092-130 that connects on MAIN connector
- 1x DB-9 for PORT A in RS-232 mode, with access to SYNC IN A and SYNC OUT A
- 1x RJ-45 plug for Ethernet connection
- 1x Female DB-9 plug for CAN bus output
- 1x Male SMA plug for Sync OUT B (For time sync with external equipment)
- Total length: 50cm (25cm before / after cable splitter)

Connectors pin-outs are defined below:

Pin on DB-9 "PORT A"	Function	Pin on DB-9 "CAN"	Function	Pin on RJ45 ETH	Function
1	SYNC IN A	2	CAN L	1	Tx+
2	PORT A RX	3	GND	2	Tx-
3	PORT A TX	7	CAN H	3	Rx+
4	SYNC OUT A			6	Rx-
5	GND				

Pin on SMA "SYNC OUT B"	Function
Central pin	SYNC OUT B
Outer	GND

7.4.9. CA-AEK-SPLIT-AUX-0.5M

This cable provides a robust and easy access to all serial ports available on the EKINOX AUX connector using standard DB-9 plugs.

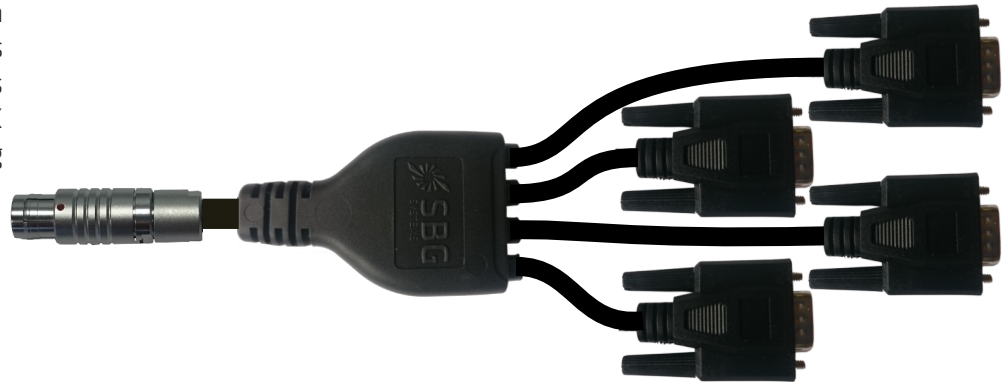

Figure 7.12: CA-AEK-SPLIT-AUX-0.5M – Lengths not to scale

The cable has following characteristics:

- 1 x Fischer Core Series S-104-A092-130 that connects on MAIN connector
- 4x DB-9 for PORT B C, D and E in RS-232/RS-422 modes
- Total length: 50cm (25cm before / after cable splitter)
- Weight: TBD

Connectors pin-outs are defined below:

Pin on DB-9 "PORT B/C"	Function
1	SYNC IN B/C
2	PORT B/C RS232 Rx / RS-422 Rx+
3	PORT B/C RS232 Tx / RS422 TX-
5	GND
6	PORT B/C RS422 Rx-
7	PORT B/C RS422 Tx+

Pin on DB-9 "PORT D/E"	Function
1	SYNC IN D/E
2	PORT D/E RS232 Rx / RS-422 Rx+
5	GND
6	PORT D/E RS422 Rx-