

QUANTA series

High performance OEM navigation systems

Hardware Manual

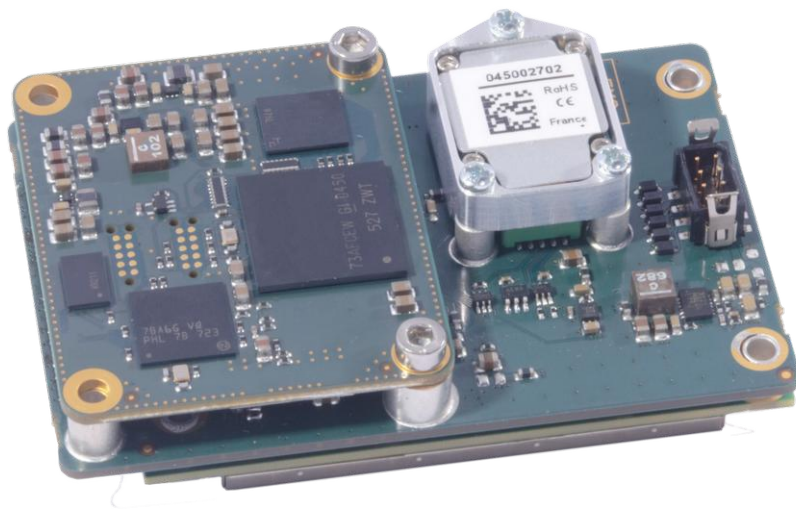

Document
Revision

QUANTAHM.1.2
1.2 - May 15, 2020

Support

support@sbg-systems.com
+33 1 80 88 45 00

SBG Systems
1, avenue Eiffel
78420 Carrières-sur-Seine
FRANCE

Revision history

Rev.	Date	Author	Information
1.2	May 15, 2020	AG	[QUANTAHM-7] Fixed invalid Quanta coordinate frame definition [QUANTAHM-8] Fixed description of the Main connector in section 3.3.1 [QUANTAHM-9] Fixed typo in vertical and horizontal velocity accuracy [QUANTAHM-10] Remove obsolete specifications [QUANTAHM-13] Fixed products weight typo
1.1	September 25, 2019	AG	[QUANTAHM-5] Add GNSS antenna connector specifications [QUANTAHM-6] Add virtual odometer feature
1.0	September 19, 2019	AG	[QUANTAHM-1] Update development board schematics [QUANTAHM-2] Updated product naming [QUANTAHM-3] updated Quanta coordinate frame [QUANTAHM-4] Updated electrical specifications (input power supply)
0.95	April 23, 2019	AG	Pre version

Index

- Terminology..... 6
- 1. Introduction..... 7
- 2. Performance specification..... 8
 - 2.1. Inertial measurement unit..... 8
 - 2.1.1. Accelerometers..... 8
 - 2.1.2. Gyroscopes..... 8
 - 2.2. Aiding sensors..... 9
 - 2.2.1. Internal GNSS receiver..... 9
 - 2.2.2. External sensors..... 10
 - 2.2.2.1. Odometer..... 10
 - 2.3. System Performance..... 10
 - 2.3.1. UAV / Airborne applications..... 10
 - 2.3.1.1. Quanta..... 10
 - 2.3.1.2. Quanta Extra..... 10
 - 2.3.2. Land applications..... 11
 - 2.3.2.1. Quanta..... 11
 - 2.3.2.2. Quanta Extra..... 11
- 3. Quanta Mechanical and Electrical integration..... 12
 - 3.1. Quanta Mechanical specifications..... 12
 - 3.1.1. Reference coordinate frame..... 12
 - 3.1.2. Center of measurements location..... 13
 - 3.1.3. Drawings..... 13
 - 3.1.3.1. Top and bottom views..... 13
 - 3.1.3.2. Side view..... 14
 - 3.2. Quanta with External IMU Mechanical outline..... 14
 - 3.2.1. Top and bottom views..... 14
 - 3.2.2. Side view..... 15
 - 3.3. Electrical specifications..... 15
 - 3.3.1. Main Connector..... 15
 - 3.3.1.1. Pin out..... 16
 - 3.3.1.2. Electrical specifications..... 17
 - 3.3.2. External IMU connector..... 18
 - 3.3.2.1. Type..... 18
 - 3.3.2.2. Pin-out..... 18
 - 3.3.2.3. Electrical specifications..... 18
 - 3.3.3. GNSS antenna connectors..... 19
 - 3.4. Reference design..... 19
 - 3.4.1. Power supply..... 19
 - 3.4.2. Serial ports connection guidelines..... 19
 - 3.4.2.1. Quanta main communication interface..... 20
 - 3.4.2.2. Data output..... 20
 - 3.4.2.3. RTCM input for RTK operation..... 20

- 3.4.2.4. Odometer integration..... 20
- 3.4.2.5. Third party equipment connection..... 20
- 3.4.2.6. Synchronization input and output functions..... 20
- 3.4.3. Ethernet interface..... 21
- 3.4.4. CAN bus..... 21
- 3.4.5. LEDs integration..... 22
- 4. Quanta EXTRA IMU integration..... 23**
 - 4.1. Reference coordinate frame..... 23
 - 4.2. Mechanical specifications..... 23
 - 4.2.1. Mechanical outline..... 24
 - 4.2.1.1. Top and bottom views..... 24
 - 4.2.1.2. Side and front views..... 24
 - 4.3. Electrical specifications..... 25
 - 4.3.1. Connector specification..... 25
 - 4.3.2. Pin-out..... 25
 - 4.3.3. Electrical specifications..... 26
 - 4.3.4. Absolute maximum ratings..... 26
 - 4.3.5. Integration..... 26
- 5. Important notices..... 27**
 - 5.1. Support..... 27
 - 5.2. Warranty, liability and return procedure..... 27
- 6. Appendix A: Ordering codes and Accessories..... 28**
 - 6.1. Processing modules hardware codes..... 28
 - 6.2. Accessories..... 28
 - 6.2.1. Qinertia GNSS/INS post-processing software..... 28
 - 6.2.2. QUANTA DEV KIT..... 29
 - 6.2.3. QUANTA IMU CABLE 50CM..... 29
 - 6.3. GNSS antennas and associated cables..... 30
 - 6.3.1. ANT-MAX-M7HCT-A-SMA..... 30
 - 6.3.1.1. Performance specifications..... 30
 - 6.3.1.2. Mechanical drawing..... 30
 - 6.3.2. ANT-ACM-G5ANT-1A196MNS-1..... 31
 - 6.3.2.1. Performance specifications..... 31
 - 6.3.2.2. Mechanical drawing..... 31
- 7. APPENDIX B: Packaging, labeling..... 32**
 - 7.1. Board Identification..... 32
- 8. APPENDIX C: Safety Information..... 33**
- 9. APPENDIX D: Environmental Statements..... 34**
 - 9.1. RoHS statement..... 34
 - 9.2. WEEE statement..... 34
- 10. APPENDIX E: Development board specifications..... 35**
 - 10.1. Board overview..... 35

- 10.2. Interfaces specifications..... 35
 - 10.2.1. Power input..... 35
 - 10.2.2. Ethernet..... 36
 - 10.2.3. PORT A..... 36
 - 10.2.4. PORT B..... 36
 - 10.2.5. PORT C and PORT D..... 37
 - 10.2.6. PORT E / Odometer input..... 38
 - 10.2.7. CAN..... 38
- 10.3. Default switches configuration..... 39
- 10.4. Schematics..... 40

Terminology

ADC: Analog to Digital Converter
AHRS: Attitude and Heading Reference System
CAN (Bus): Controller Area Network
DHCP: Dynamic Host Configuration Protocol
DVL: Doppler Velocity Log
EKF: Extended Kalman Filter
EEPROM: Electrically-Erasable Programmable Read-Only Memory
FIR: Finite Impulse Response (filter)
FTP: File Transfer Protocol
FS: Full Scale
FOG: Fiber Optic Gyroscope
GNSS: Global Navigation Satellite System
GPS: Global Positioning System
IMU: Inertial Measurement Unit
INS: Inertial Navigation System
IP: Internet Protocol
LBL: Long Baseline
MAC (address): Media Access Control
MEMS: Micro Electro-Mechanical Systems
NED: North East Down (coordinate frame)
NA: Not applicable
NMEA (NMEA 0183): National Marine Electronics Association (standardized communication protocol)
PPS: Pulse Per Second (signal)
RAM: Random Access Memory
RMA: Return Merchandise Authorization
RMS: Root Mean Square
RTCM: Radio Technical Commission for Maritime Services (Protocol)
RTK: Real Time Kinematics
SI: International System of Units
TBD: To Be Defined
TCP: Transmission Control Protocol
UDP: User Datagram Protocol
UTC: Coordinated Universal Time
USBL: Ultra Short Base Line
VRE: Vibration Rectification Error
WGS84: World Geodetic System 1984
WMM: World Magnetic Model

1. Introduction

Quanta series is a line of high performance inertial navigation systems. The highly integrated OEM package enables integration into a wide range of applications in all environments.

Focusing on high performance application, its multi-frequency, multi-constellation GNSS receiver enables centimetre precision in real time or in post-processing and is particularly suitable for harsh environments. It also features a dual antenna heading that provides optimal heading performance, even in low dynamic applications.

The two performance levels offered in Quanta series also provides a full answer to all technical needs, from the cost and size constrained applications to the most challenging applications.

Specific features such as intuitive web interface, internal datalogger and easy interfacing with Qinertia post-processing software makes an ideal solution for most survey markets.

QUANTA can address any land and air application. QUANTA solution is ideal for UAV based photogrammetry and LIDAR direct-georeferencing applications thanks to a tight integration and cost effective pricing. A 12 months Qinertia UAV subscription is even offered with each QUANTA to access optimal heading performance, even in low dynamic flights or single antenna usage

While standard performance grade will be suitable to most applications, the “Extra” performance grade will enable ultimate performance in the most difficult conditions.

The following diagram shows the basic functions of Quanta series.

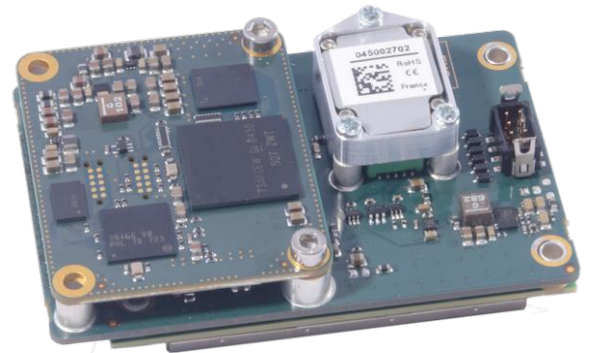

Figure 1.1: Quanta series overview

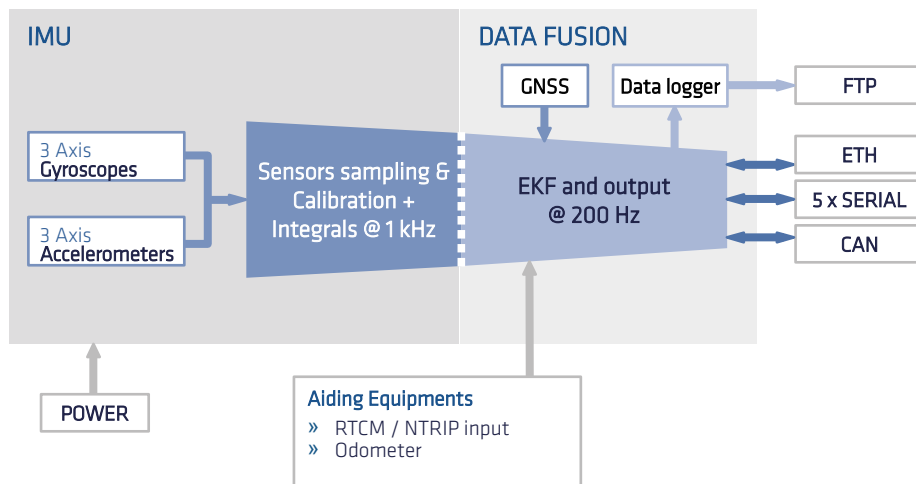

Figure 1.2: Quanta solution simplified block diagram

2. Performance specification

Performance specifications presented in this section may vary from one Quanta configuration to the other.

2.1. Inertial measurement unit

As an IMU is the main component of an inertial navigation system, the Quanta IMU has been carefully designed to take full advantage and performance of MEMS technology.

2.1.1. Accelerometers

Quanta IMUs embed a set of 3 MEMS capacitive accelerometers that provide a consistent performance in all conditions, including vibrating environments.

The specifications are listed in the table below, depending on the IMU configuration.

IMU configuration	Standard	Extra	Remarks
Full scale (g)	± 16	± 10	
Velocity Random Walk (µg/√Hz)	57	30	Allan variance - @ 25°C
In run bias instability (µg)	14	7	Allan variance - @ 25°C
Bandwidth (Hz)	390	100	Attenuation of 3 dB
Orthogonality (°)	0.05	< 0.02	Over temperature range

2.1.2. Gyroscopes

Quanta IMUs embed 3 MEMS gyroscopes. The specifications are listed below and depend on the performance grade chosen:

	Standard	Extra	Remarks
Full scale (°/s)	± 400	± 200	
In run bias instability (°/hr)	7	0.05	Allan variance - @ 25°C
Angular Random Walk (°/√hr)	0.15	0.012	Allan variance - @ 25°C
Bandwidth (Hz)	< 133	100	Attenuation of 3 dB
Orthogonality (°)	0.05	0.02	Over temperature range

2.2. Aiding sensors

Many different aiding sensors can be used to aid the Quanta INS.

2.2.1. Internal GNSS receiver

The Quanta series embed a high end, survey grade GNSS receiver that comes in dual antenna configuration.

It features dual band, quad constellation tracking (all enabled by default) to provide reliable position even in harsh environments.

This latest generation GNSS receiver also features very accurate RTK positioning with the world's leading signal availability and minimal re-acquisition time after a GPS outage. The RAW data output enables seamless integration with Qinertia software. Advanced auto mitigating algorithms detect and eliminate typical jamming or multi-path issues.

	Specification		Remark
Channels	448		
Signal tracking	GPS: L1, L2, L2C GLONASS: L1, L2 GALILEO: E1 B/C, E5b	Beidou B1, B2, SBAS, QZSS L1, L2C	All constellations & signals enabled by default
Horizontal position accuracy	Single point L1/L2	1.2 m	RTK precision available in option
	SBAS / DGPS	0.6 m / 0.4 m	
	RTK	1 cm + 1ppm	
Velocity accuracy	0.03 m/s RMS		
True Heading Accuracy	0.15°	1m baseline	
	0.1°	2m baseline	
Velocity limit	515 m/s		Due to export licenses
Time to First Fix	Cold start	< 45 s	
	Hot start	< 20s	
Signal reacquisition			1s
Output frequency	5 Hz		
Diff. Corrections	RTCM V2.x, V3.x CMR V2.0, CMR+		Sent via serial PORT D
Options	RTK		



Note: All these specifications reflect the intrinsic GNSS receiver accuracy. Please refers to section 2.3 System Performance for complete Quanta accuracy specifications.

2.2.2. External sensors

2.2.2.1. Odometer

In addition to the GNSS aiding, the Quanta Land series include an odometer input which can greatly improve performance in challenging environments such as urban canyons. The odometer provides a reliable velocity information even during GPS outages. This increases significantly the dead reckoning accuracy.

Quanta series handle quadrature output or compatible odometers in order to support forward and backward directions.



Note: Odometer integration is made really simple as the Kalman filter will finely adjust odometer's gain and will correct residual errors in the odometer alignment and lever arm.

2.3. System Performance

All specifications are rated to 1 σ , over -40°C to +85°C (-40 to 185°F) unless otherwise stated.

These specifications have been measured based on typical mission scenarios with simulated GPS outages and compared to post processed RTK data of a high end FOG based INS.

For each application, the accuracy parameters are defined in different positioning modes, explained below:

- SP refers to Single Point mode and is the default fix quality
- RTK stands for Real Time Kinematics with a typical 1 cm position accuracy
- PPK is the post-processed accuracy with a base station, providing a 1cm position accuracy.

2.3.1. UAV / Airborne applications

2.3.1.1. Quanta

Positioning Mode	Position Accuracy		Velocity Accuracy		Attitude Accuracy (°)	
	Horizontal	Vertical	Horizontal	Vertical	Roll / Pitch	Heading
SP	1.2 m	1.5 m	0.03 m/s	0.02 m/s	0.05 °	0.5 single ant. / baseline > 0.3m
RTK	0.01 m	0.03 m	0.02 m/s	0.01 m/s	0.03 °	0.2 ° (baseline > 1m)
PPK	0.01 m	0.02 m	0.01 m/s	0.01 m/s	0.025 °	0.08 °

2.3.1.2. Quanta Extra

Positioning Mode	Position Accuracy		Velocity Accuracy		Attitude Accuracy (°)	
	Horizontal	Vertical	Horizontal	Vertical	Roll / Pitch	Heading
SP	1.0	1.0	0.02	0.01	0.01	0.1 single ant. / baseline > 0.5m
RTK	0.01	0.03	0.01	0.01	0.008	0.06 ° (baseline > 1m)
PPK	0.01	0.02	0.01	0.01	0.005	0.025

2.3.2. Land applications

2.3.2.1. Quanta

All specifications are valid with DMI (odometer) aiding for typical land applications trajectories.

Outage Duration	Positioning Mode	Position Accuracy (m)		Velocity Accuracy (m/s)		Attitude Accuracy (°)	
		Horizontal	Vertical	Horizontal	Vertical	Roll / Pitch	Heading
No Outage	SP	1.2	1.5	0.03	0.02	0.05	0.2
	RTK	0.01	0.03	0.02	0.01	0.03	0.15
	PPK	0.01	0.02	0.01	0.01	0.025	0.08
10 s	SP	1.5	2	0.1 m/s	0.1 m/s	0.05	0.3
	RTK	0.15	0.1	0.1 m/s	0.1 m/s	0.03	0.25
	PPK	0.05	0.03	0.05	0.03	0.03	0.1
60 s	SP	9	6	0.1	0.1	0.1	0.5
	RTK	7	4	0.1	0.1	0.05	0.3
	PPK	1	0.5	0.05	0.05	0.04	0.2

2.3.2.2. Quanta Extra

All specifications are valid with DMI (odometer) aiding for typical land applications trajectories.

Outage Duration	Positioning Mode	Position Accuracy (m)		Velocity Accuracy (m/s)		Attitude Accuracy (°)	
		Horizontal	Vertical	Horizontal	Vertical	Roll / Pitch	Heading
No Outage	SP	1.0	1.0	0.02	0.01	0.01	0.04
	RTK	0.01	0.03	0.01	0.01	0.008	0.04
	PPK	0.01	0.02	0.01	0.01	0.005	0.02
10 s	SP	1.1	1.0	0.03	0.02	0.01	0.04
	RTK	0.05	0.05	0.02	0.02	0.008	0.04
	PPK	0.02	0.02	0.015	0.01	0.005	0.02
60 s / 1km	SP	1.5	1.3	0.03	0.02	0.015	0.06
	RTK	0.5	0.3	0.02	0.02	0.012	0.06
	PPK	0.1	0.05	0.02	0.015	0.008	0.025

3. Quanta Mechanical and Electrical integration

3.1. Quanta Mechanical specifications

The table below summarizes all mechanical and environmental specifications.

Item	Specification
Size	78.7 x 51.5 x 22.2 mm
Weight	75g (internal IMU) 65 g (external IMU)
Shocks	500 g for 0.3 ms
Operating Vibrations	8g RMS – 20Hz to 2 kHz as per MIL-STD-810G
Operating temperature	-40 to 71 °C
Storage	-40 to 85°C
Humidity	MIL-STD-810G, Method 507.5 Procedure II (95%)
MTBF (computed)	50,000 hours

3.1.1. Reference coordinate frame

The following reference coordinate frame should be considered when measuring the lever arms and distances from the product to the point of interest (eg. GNSS antenna).

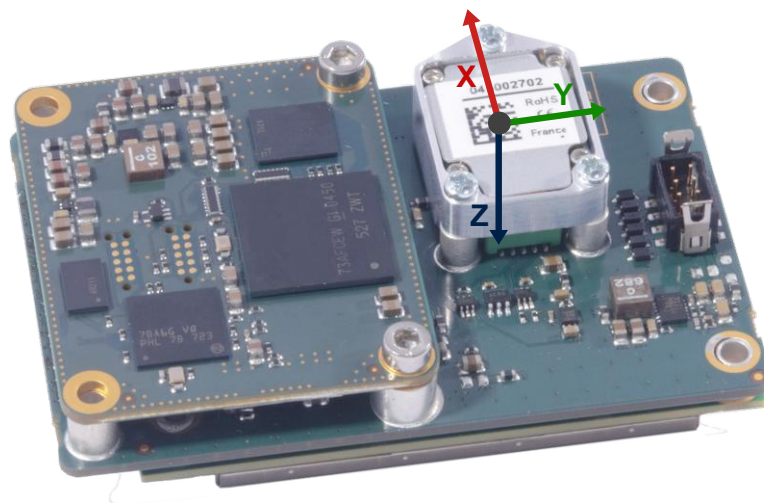

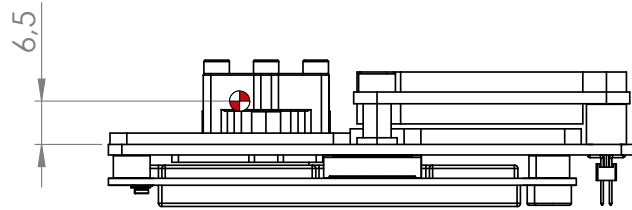
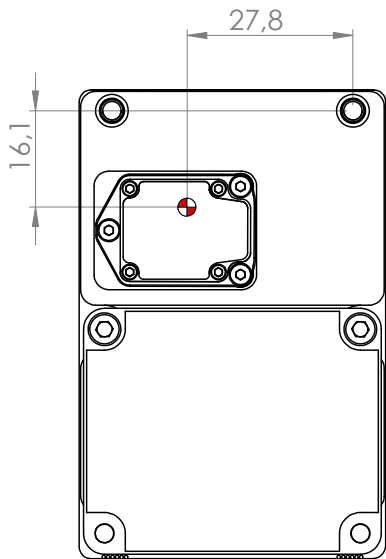

Figure 3.1: Quanta coordinate frame (internal IMU)

3.1.2. Center of measurements location

The symbol  locates the center of measurements.



3.1.3. Drawings

All dimensions are in mm. 3D models are available in CAD files upon request.

3.1.3.1. Top and bottom views

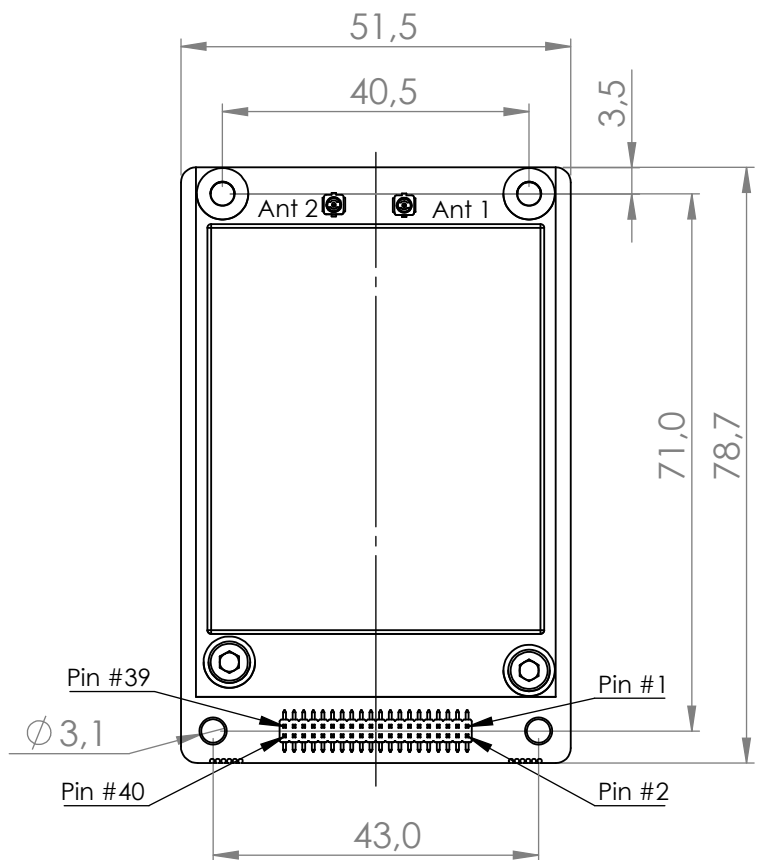
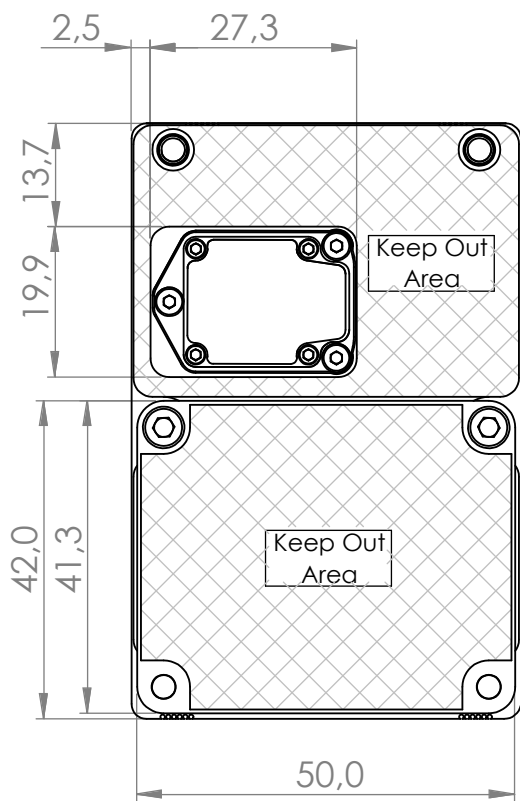

3.1.3.2. Side view

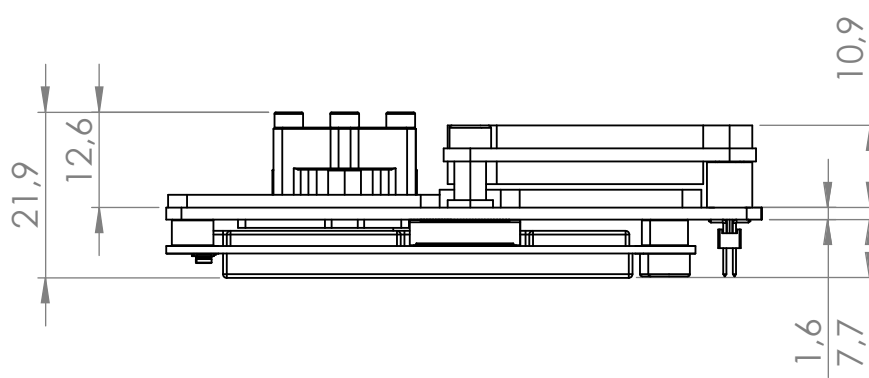

3.2. Quanta with External IMU Mechanical outline

3.2.1. Top and bottom views

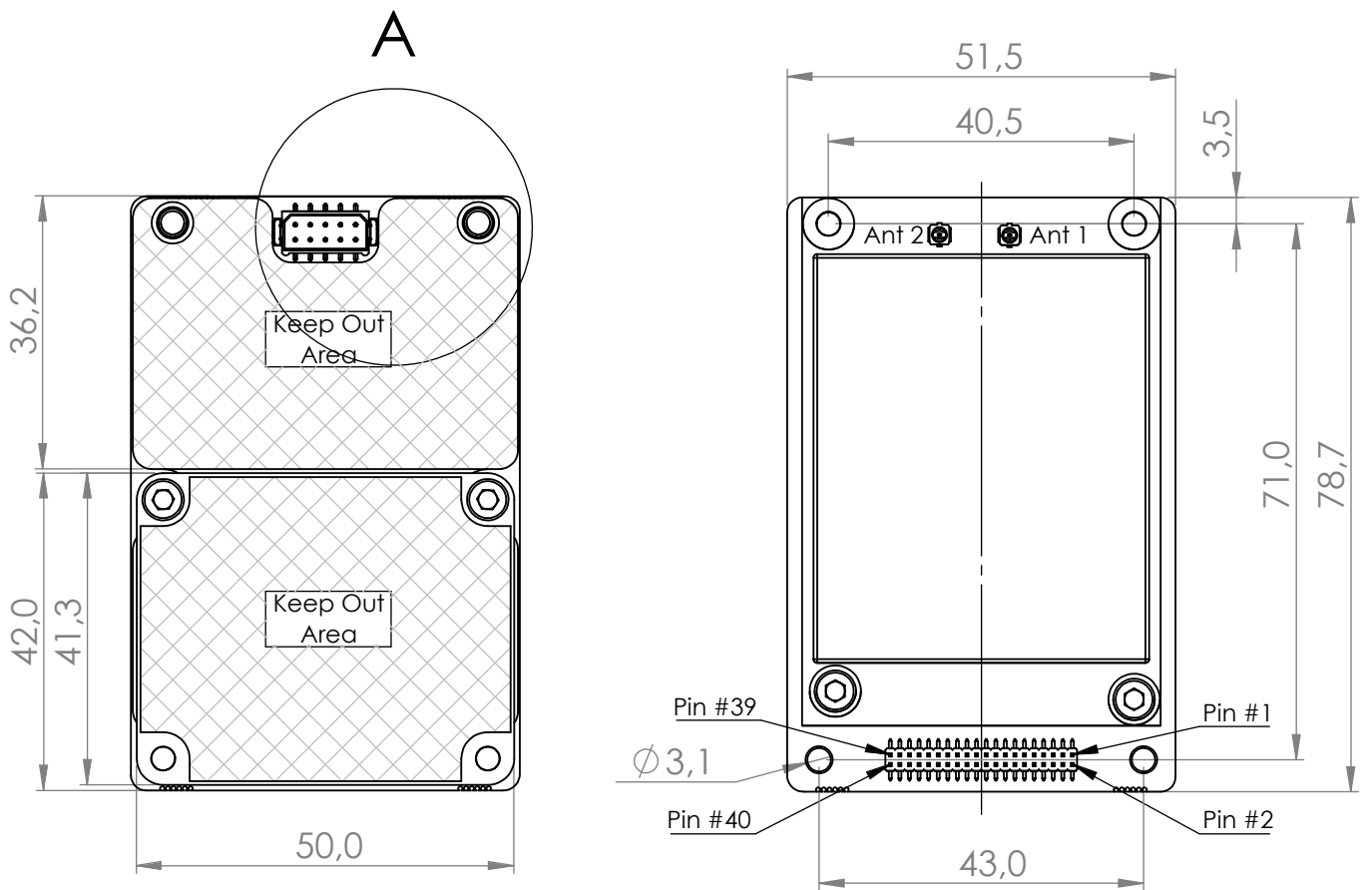

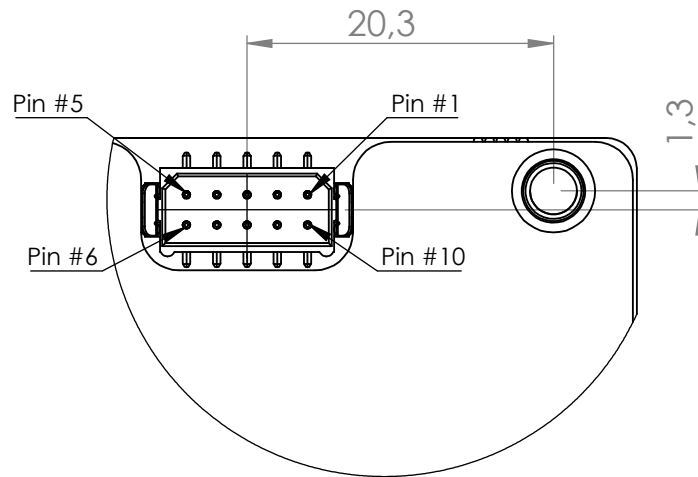

3.2.2. Side view

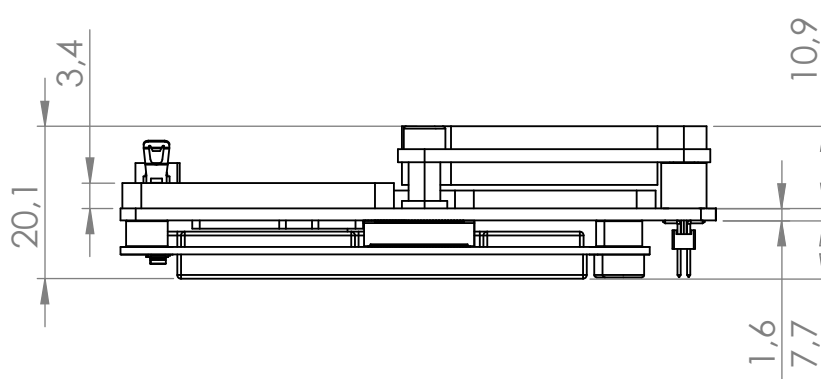

3.3. Electrical specifications

3.3.1. Main Connector

Connector	Manufacturer	Part number	Description
Quanta main connector	ANTELEC	AM2D-127-40-3.7-3.8-G-CMS-H25	Connector, Male, Vertical, 40 cts, 1.27mm pitch, SMD
Mating connector	-	-	Any DIL, 1.27mm pitch, SMD or TH connector



Note: The pin numbering may not be the same as the one used by the connector manufacturer. Please refer to SBG provided pin numbering (in drawings)

3.3.1.1. Pin out

Pin #	Signal Name	Type	Description	Connection tips
1	VDD	Power Input	Main Power Supply Input	Both VCC pins (Pin#1 and Pin#2) must be tied together.
2	VDD	Power Input	Main Power Supply Input	
3	GND	Ground	Signal Voltage Reference	All ground pins must be connected.
4	GND	Ground	Signal Voltage Reference	All ground pins must be connected.
5	ETHERNET_PORT_RX+	Ethernet Input	Ethernet Port Receive Signal (+)	Leave unconnected if not used. See section 3.4.3 Ethernet interface otherwise.
6	ETHERNET_PORT_TX+	Ethernet Output	Ethernet Port Transmit Signal (+)	
7	ETHERNET_PORT_RX-	Ethernet Input	Ethernet Port Receive Signal (-)	
8	ETHERNET_PORT_TX-	Ethernet Output	Ethernet Port Transmit Signal (-)	
9	GND	Ground	Signal Voltage Reference	All ground pins must be connected.
10	GND	Ground	Signal Voltage Reference	All ground pins must be connected.
11	INS_LED_A	LVTTL Output	INS Led Output A	Leave unconnected if not used.
12	GNSS_LED_A	LVTTL Output	GNSS Led Output A	Leave unconnected if not used.
13	INS_LED_B	LVTTL Output	INS Led Output B	Leave unconnected if not used.
14	GNSS_LED_B	LVTTL Output	GNSS Led Output B	Leave unconnected if not used.
15	GND	Ground	Signal Voltage Reference	All ground pins must be connected.
16	GND	Ground	Signal Voltage Reference	All ground pins must be connected.
17	CAN_TX	LVTTL Output	CAN Transmit	Leave unconnected if not used.
18	PORTA_TX	LVTTL Output	PORT A UART Transmit	Leave unconnected if not used.
19	CAN_RX	LVTTL Input	CAN Receive	Leave unconnected if not used.
20	PORTA_RX	LVTTL Input	PORT A UART Receive	Tie to GND if not used.
21	GND	Ground	Signal Voltage Reference	All ground pins must be connected.
22	SYNC_IN_A	LVTTL Input	Synchronization Input A	Leave unconnected if not used.
23	SYNC_OUT_B	LVTTL Output	Synchronization Output B	Leave unconnected if not used.
24	SYNC_OUT_A	LVTTL Output	Synchronization Output A	Leave unconnected if not used.
25	PORTC_TX	LVTTL Output	PORT C UART Transmit	Leave unconnected if not used.
26	PORTB_TX	LVTTL Output	PORT B UART Transmit	Leave unconnected if not used.
27	PORTC_RX	LVTTL Input	PORT C UART Receive	Tie to GND if not used.
28	PORTB_RX	LVTTL Input	PORT B UART Receive	Tie to GND if not used.
29	SYNC_IN_C	LVTTL Input	Synchronization Input C	Leave unconnected if not used.
30	SYNC_IN_B	LVTTL Input	Synchronization Input B	Leave unconnected if not used.
31	GND	Ground	Signal Voltage Reference	All ground pins must be connected.
32	GND	Ground	Signal Voltage Reference	All ground pins must be connected.
33	PORTD_TX	LVTTL Output	PORT D UART Transmit	Leave unconnected if not used.
34	PORTE_TX	LVTTL Output	PORT E UART Transmit	Leave unconnected if not used.
35	PORTD_RX	LVTTL Input	PORT D UART Receive	Tie to GND if not used.
36	PORTE_RX/ODO_A	LVTTL Input	PORT E UART Receive / Odometer A Channel	Tie to GND if not used.

Pin #	Signal Name	Type	Description	Connection tips
37	SYNC_IN_D	LVTTL Input	Synchronization Input D	Leave unconnected if not used.
38	SYNC_IN_E/ODO_B	LVTTL Input	Synchronization Input E Odometer B Channel	Leave unconnected if not used.
39	GND	Ground	Signal Voltage Reference	All ground pins must be connected.
40	GND	Ground	Signal Voltage Reference	All ground pins must be connected.



Note: All Synchronization inputs and outputs, as well as odometer input pins have inverted polarity when compared to the firmware documentation and web page configuration. The “Rising edge” configuration in the web page / firmware will be in fact triggered on the falling edge at hardware level. This is because these inputs and outputs have been optimized for direct interfacing to a RS-232 receiver or driver, which can enable robust and safe connection to remote equipment.

An external inverting buffer can also be used to maintain LVTTL levels while putting back the signals to the same polarity as the firmware.

3.3.1.2. Electrical specifications

Item	Conditions	Min	Typical	Max	Unit
Power supply					
Input voltage range		4.75	5	5.25	V
Power consumption	Quanta with Internal IMU		3.5		W
	Quanta Extra		6		W
TTL Input pins					
Input range	5V tolerant LVTTL	0	3.3	5	V
Low level threshold				0.8	V
High level threshold		2.0			V
Input current				40	µA
TTL output pins					
Low level voltage			0	0.4	V
High level voltage		2.8	3.3		V
Max output current				20	mA

3.3.2. External IMU connector

3.3.2.1. Type

Connectors	Manufacturer	Manufacturer P/N	Description
Processing Micro-Module	NICOMATIC	201T10L	Connector, Datamate L-Tek serie, Male, Vertical, 10 cts, 2.2A, 2mm pitch, SMD
Mating board Connector	HARWIN	M80-8881005	Connector, Datamate L-Tek serie, Female, 10 cts, 24-28 AWG, 2mm pitch, Cable Mount
Mating board Connector	HARWIN	M80-8891005	Connector, Datamate L-Tek serie, Female, 10 cts, 22 AWG, 2mm pitch, Cable Mount
Mating board Connector	NICOMATIC	202C10	Connector, CMM200 serie, Female, 10 cts, 22 AWG, 2mm pitch, Cable Mount

3.3.2.2. Pin-out

Pin #	Signal Name	Type	Description	Connection tips
1	VDD_EXT_IMU	Power Output	Power Supply Output for remote IMU, 300mA capability	
2	PORT_IMU_RX-	Input	Port IMU Data Receive Input Signal (-), features 1200hm termination resistor	
3	PORT_IMU_TX-	Output	Port IMU Data Transmit Output Signal (-)	Place a 1200hm termination resistor near the receiver
4	PORT_IMU_SYNC_IN-	Input	IMU Synchronization Input Signal (-), features 1200hm termination resistor	
5	GND	Ground	Signal Voltage Reference	Pins 5, 6 and 10 connected together. Use at least one pin for ground connection.
6	GND	Ground	Signal Voltage Reference	
7	PORT_IMU_RX+	Input	Port IMU Data Receive Signal (+), features 1200hm termination resistor	
8	PORT_IMU_TX+	Output	Port IMU Data Transmit Signal (+)	Place a 1200hm termination resistor near the receiver
9	PORT_IMU_SYNC_IN+	Input	Port IMU Synchronization Input Signal (+), features 1200hm termination resistor	
10	GND	Ground	Signal Voltage Reference	Pins 5, 6 and 10 connected together. Use at least one pin for ground connection.

3.3.2.3. Electrical specifications

Item	Conditions	Min	Typical	Max	Unit
Power supply					
Output voltage			12		V
Max output current			300		mA
RS-422 Receivers / SYNC IN					
Receiver Common Mode range		-7		12	V
Input differential threshold		-200	-125	-50	mV
Input hysteresis			25		mV

Item	Conditions	Min	Typical	Max	Unit
Input resistance			120		Ω
RS-422 transmitters					
Differential output voltage		1.5	2.2	3.3	V
Driver output current				60	mA

3.3.3. GNSS antenna connectors

The GNSS antenna connectors are located on the bottom of the GNSS receiver module.

The connector type is UFL. Main antenna should be connected to ANTA and secondary antenna should be connected to ANTB.

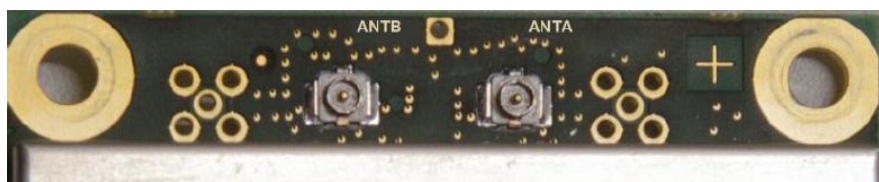

Figure 3.2: GNSS Antenna connectors

3.4. Reference design

3.4.1. Power supply

To power supply Quanta module, It is recommended to select a power supply with 1500mA average and 2000mA peak current capabilities in 5.0V.

Note that optimal power consumption is obtained at 5.0V input.

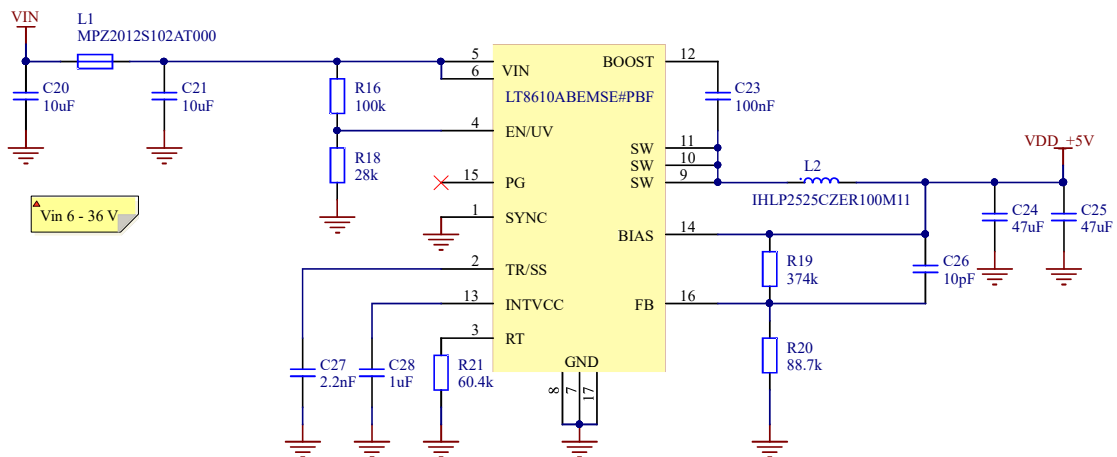

Figure 3.3: Example of power supply schematic

3.4.2. Serial ports connection guidelines

As Quanta hardware delivers LVTTTL inputs and outputs, the serial interfaces should be driven to an appropriate transceiver in case of communication with external equipment. Low distance communication can be performed in LVTTTL format. Some serial ports have specific functions that are described below.

3.4.2.1. Quanta main communication interface

Port A is the main communication interface with the host computer, via sbgECom protocol. It can be used to get outputs as well as to configure the system.

3.4.2.2. Data output

PORT A, B and C can be configured to output data in a very customized way.

3.4.2.3. RTCM input for RTK operation

RTCM input should be provided on PORT D Rx. In such case, the PORT D Tx will generate a 1Hz GGA message for optimal network RTK operation.

3.4.2.4. Odometer integration

Odometers should be connected on PORT E Rx (A signal) and PORT E Sync IN (B signal).

3.4.2.5. Third party equipment connection

Remaining serial ports and synchronization pins can be used to connect a third party equipment, either for data output, or for aiding data input (DVL).

3.4.2.6. Synchronization input and output functions

Sync IN pins can be used to trigger external events and input external PPS information.

Sync Out A and B pins can be configured in the following modes:

- **Main loop divider:** This event is activated at the sensor sample time, but its frequency is divided by the output divider. If the divider is set to 4, pulse output frequency will be $200\text{Hz} / 4 = 50\text{Hz}$.
- **PPS:** This simple output is synchronized with each top of UTC seconds. Validity should be checked by parsing the UTC messages status.
- **Virtual odometer.** This output generates a pulse each X meters of travel, depending on user configuration.

3.4.3. Ethernet interface

The micro module can be interfaced with other Ethernet peripherals in different ways.

When the connection involves a long distance communication (typically, when there is a cable), the first implementation is required. When the device is located on the same electronic board, it is possible to select an easy circuit with capacitors.

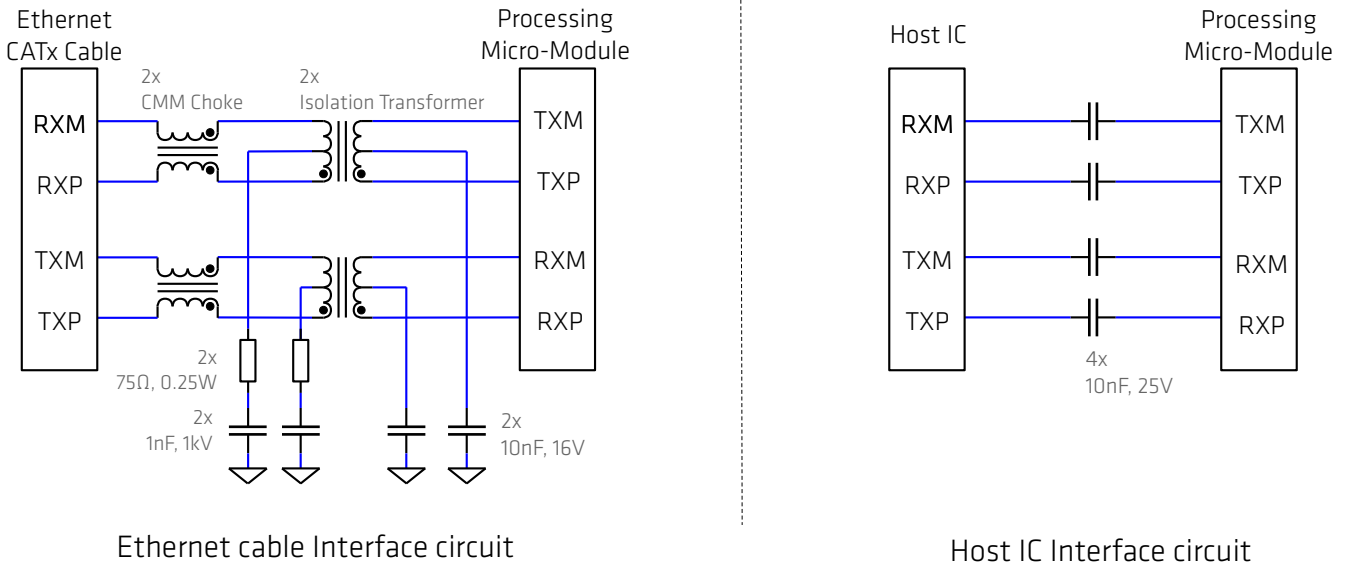

Figure 3.4: Ethernet interface implementation

3.4.4. CAN bus

The processing micro module does not integrate a CAN bus driver. Therefore, a driver integration is required in case the CAN bus output is used in user application. The following schematic shows a typical driver integration:

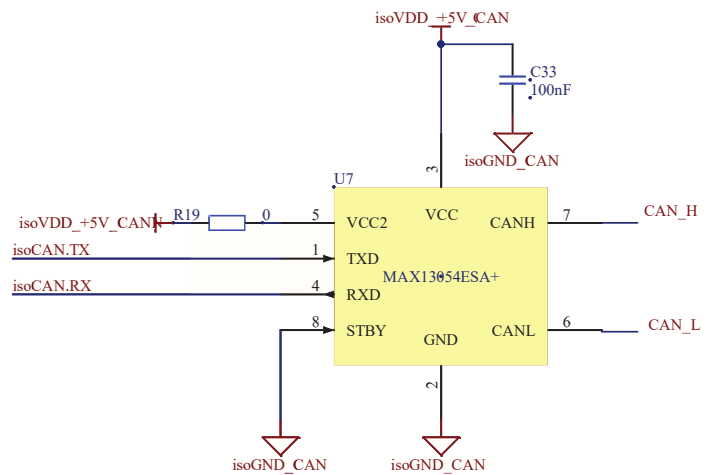

Figure 3.5: CAN bus interface reference design

3.4.5. LEDs integration

The Quanta module integrates LED output pins to ensure basic HMI functions:

- GNSS status LEDs
- INS status LEDs

The LEDs output pins are defined as 1 = LED ON; 0V = LED OFF. For each, a LED A signal corresponds to a GREEN light and LED B corresponds to a RED light. Both signals should be put in a single LED component in order to achieve the corresponding color code:

LED	Color code
GNSS LED	OFF: No GNSS available
	BLINKING RED: Unknown positioning mode
	RED: Standalone mode
	BLINKING ORANGE: DGNSS with RTCM data older than 10 seconds
	ORANGE: Stable DGNSS mode with optimal RTCM age
	BLINKING GREEN: Float RTK or PPP solution
INS LED	OFF: Kalman filter is not yet initialized
	BLINKING RED: Vertical gyro / AHRS mode in alignment phase
	RED: Vertical gyro / AHRS in aligned mode
	BLINKING ORANGE: INS, in alignment phase. INS outputs are not all in "valid state"
	ORANGE: INS is aligned but Position/Velocity/Attitude/Heading are not all in "valid state"
	BLINKING GREEN: INS, in alignment mode. INS outputs are all in "valid state"
	GREEN: INS, is aligned and Position/Velocity/Attitude/Heading are all in "valid state"

A typical design to interface the LEDs is proposed below:

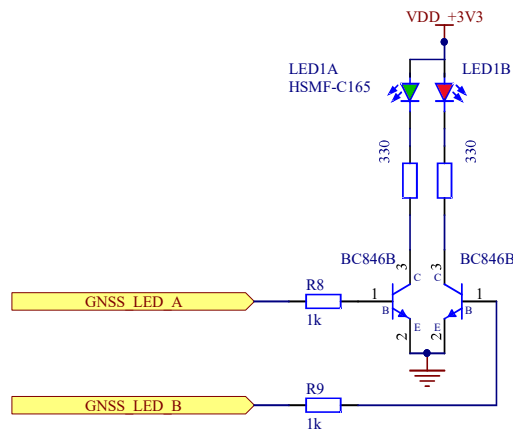

Figure 3.6: LEDs integration reference design

4. Quanta EXTRA IMU integration

4.1. Reference coordinate frame



Figure 4.1: Quanta Extra IMU coordinate frame

4.2. Mechanical specifications

The table below summarizes all mechanical and environmental specifications.

Item	Specification
Size	83.5 x 72.5 x 50 mm
Weight	295 g
Shocks	500 g for 0.3 ms
Operating Vibrations	8g RMS – 20Hz to 2 kHz as per MIL-STD-810G
Specified temperature range	-20 to 60°C
Operating temperature	-40 to 71 °C
Storage	-40 to 85°C
Humidity	MIL-STD-810G, Method 507.5 Procedure II (95%)
MTBF (computed)	50,000 hours

4.2.1. Mechanical outline

All dimensions are in mm. 3D models are available in CAD files upon request. The symbol  locates the center of measurements.

4.2.1.1. Top and bottom views

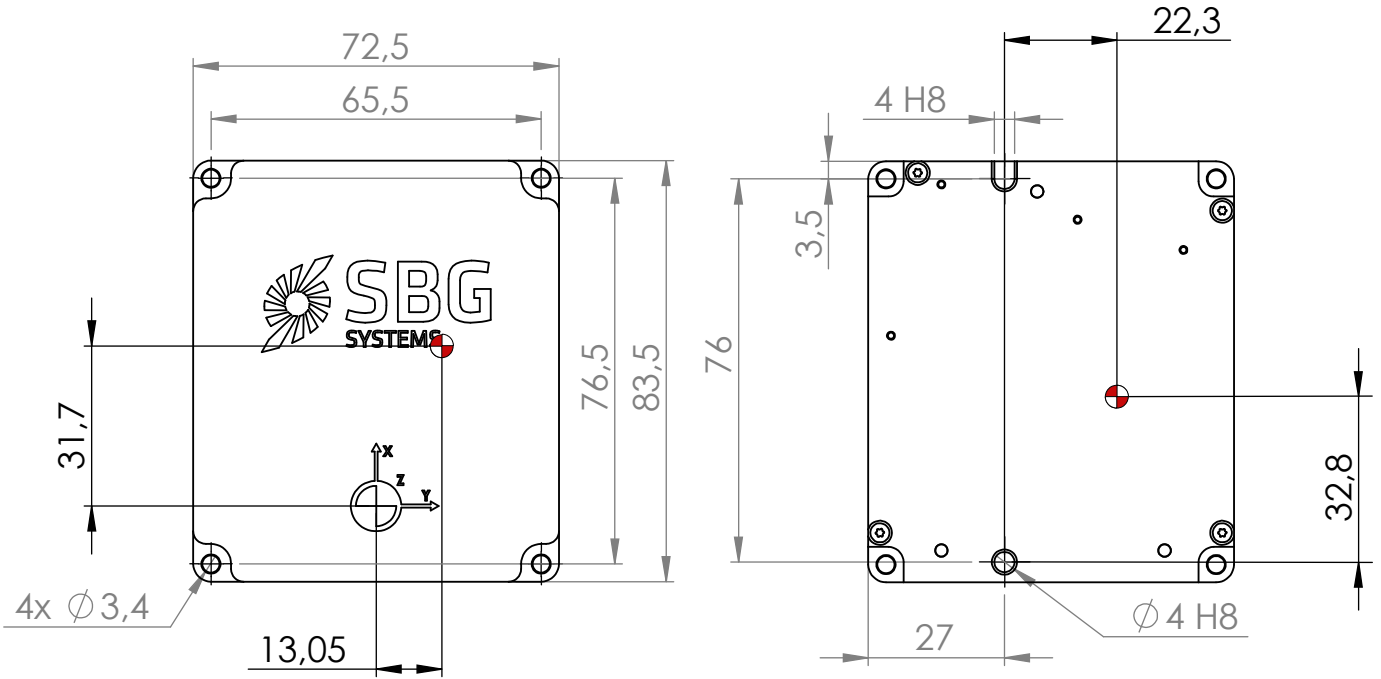

4.2.1.2. Side and front views

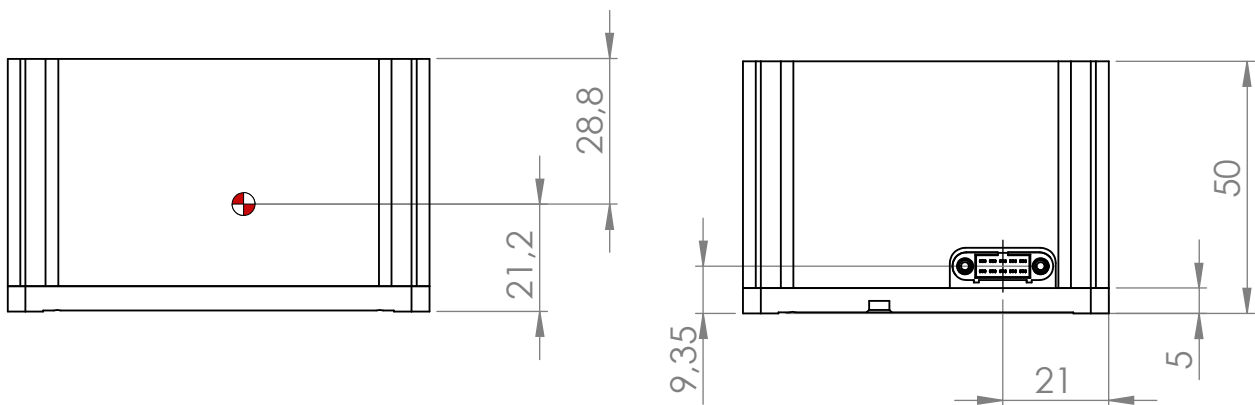

4.3. Electrical specifications

4.3.1. Connector specification

Connectors	Manufacturer	Manufacturer P/N	Description
IMU connector	NICOMATIC	221V10F25	Connector, Board mounted, Horizontal, 10 pin contacts, M2 screws assembly
Mating Connector	NICOMATIC	202S10	Connector, Male, 10cts, 2mm pitch, Jackscrews, Straight, 24-28 AWG conductors
Mating Connector	NICOMATIC	202C10	Connector, Male, 10cts, 2mm pitch, Jackscrews, Straight, 22 AWG conductors
Mating Connector	HARWIN	M80-4811005	Connector, Male, 10cts, 2mm pitch, Jackscrews, Straight, 24-28 AWG conductors
Mating Connector	HARWIN	M80-4801005	Connector, Male, 10cts, 2mm pitch, Jackscrews, Straight, 22 AWG conductors

4.3.2. Pin-out

Pin	Name	Type	Description	Connection Tips
1	VDD	Power Input	Power Supply Input, isolated from other signals	
2	TX- / B	RS422 Output RS485 I/O	RS422: Data Transmit Output Signal (- differential) RS485: Data Transmit/Receive (- differential)	RS422: Add a 120Ω termination resistor near receiver RS485: Internal 120Ω termination included
3	RX-	RS422 input	Data Receive Signal (- differential)	1200hm termination resistor included
4	SYNC_OUT-	RS422 Output	Synchronization Input Signal (- differential),	Add a 120Ω termination resistor near receiver
5	RS422 / RS485	RS232 Input	RS422 / RS485 interface mode selection pin	Leave unconnected to select RS422 mode. Tie to SGND to select RS485 mode
6	VSS	Power Return	Power Supply Return, isolated from other signals	
7	TX+ / A	RS422 Output RS485 I/O	RS422: Data Transmit Output Signal (+ differential) RS485: Data Transmit/Receive (+ differential)	Add a 120Ω termination resistor near receiver RS485: Internal 120Ω termination included
8	RX+	RS422 input	Data Receive Signal (+ differential)	1200hm termination resistor included
9	SYNC_OUT+	RS422 Output	Synchronization Input Signal (+ differential),	Add a 120Ω termination resistor near the receiver
10	SGND	I/O	Signal Reference for TX/RX and Sync Out differential pairs	

4.3.3. Electrical specifications

Item	Conditions	Min	Typical	Max	Unit
Power supply					
Input voltage		12		32	V
Power consumption			2.5		W
RS422 / RS485 selection pin					
Input voltage range		-15		15	V
RS-422 Receivers					
Receiver Common Mode range		-7		12	V
Input differential threshold		-200	-125	-50	mV
Input hysteresis			25		mV
Input resistance			120		Ω
RS-422 transmitters					
Differential output voltage		1.5	2.2	3.3	V
Driver output current				60	mA

4.3.4. Absolute maximum ratings

Parameter	Range
Power supply input voltage	+/- 40 V
RS-422 / RS-485 Selection input voltage	± 18 V
RS-422 receiver input voltage	-8 to +13 V
RS-422 Driver output current	100 mA
VDD or VSS to any RS-232, RS-422 or RS-485 signal	± 250 V

4.3.5. Integration

The External IMU "APOGEE-I-L can be directly wired to the QUANTA processing module.

5. Important notices

5.1. Support

Our goal is to provide the best experience to our customers. If you have any question, comment or problem with the use of your product, we would be glad to help you, so feel free to contact us:

EMEA:

SBG Systems S.A.S.
1, avenue Eiffel
78420 Carrières-sur-Seine
FRANCE

Phone: +33 1 80 88 43 70
support@sbg-systems.com

Americas:

SBG Systems North America, Inc
5932 Bolsa Avenue, Suite #103
Huntington Beach, CA 92649
USA

Phone: +1 (657) 549-5807
support@sbg-systems.com

5.2. Warranty, liability and return procedure

SBG Systems provides a warranty covering this product against any defect in materials or manufacture for a period of two (2) years from the date of shipment. In the event that such a defect becomes obvious during the stipulated warranty period, SBG Systems will undertake, at its sole discretion, either to repair the defective product, bearing the cost of all parts and labor, or to replace it with an identical product.

In order to avail itself of this warranty, Customer must notify SBG Systems of the defect before expiry of the warranty period and take all steps necessary to enable SBG Systems to proceed. Upon reception of required information (Sensor serial number, defect description), SBG Systems will issue an RMA and will provide return instructions. Customer shall be responsible for the packaging and the shipment of the defective product to the repair center notified by SBG Systems, the cost of such shipment being borne by Customer.

This warranty shall not be construed as covering defects, malfunctions or damages caused by improper use or inadequate maintenance of the product. Under no circumstances shall SBG Systems be due to provide repair or replacement under this warranty in order a) to repair damage caused by work done by any person not representing SBG Systems for the installation, repair or maintenance of the product; b) to repair damage caused by improper use or connection to incompatible equipment, and specifically, the opening of the housing of the equipment under warranty shall cause the warranty to be automatically canceled.

This warranty covers the product here under and is provided by SBG Systems in place of all and any other warranty whether expressed or implied. SBG Systems does not guarantee the suitability of the product under warranty for sale or any specific use.

SBG Systems' liability is limited to the repair or replacement of defective products, this being the sole remedy open to Customer in the event the warranty becomes applicable. SBG Systems cannot be held liable for indirect, special, subsequent or consequential damage, irrespective of whether SBG Systems has or has not received prior notification of the risk of occurrence of such damage.

6. Appendix A: Ordering codes and Accessories

6.1. Processing modules hardware codes

QUANTA product is identified by both hardware and software options. The hardware code identifies only the hardware configuration while a license system enable various permissions and capabilities. The following table identifies the different Quanta variants:

Product	Hardware code	Description
QUANTA	QUANTA-SSG	OEM inertial navigation system for Land/Air 12 months Qinertia UAV access offered
QUANTA RTK	QUANTA-SSG	OEM inertial navigation system for Land/Air (RTK) 12 months Qinertia UAV access offered
QUANTA Extra	QUANTA-SXG	OEM inertial navigation system for Land/Air with Extra performance 12 months Qinertia UAV access offered
QUANTA Extra RTK	QUANTA-SXG	OEM inertial navigation system for Land/Air (RTK) with Extra performance 12 months Qinertia UAV access offered

6.2. Accessories

6.2.1. Qinertia GNSS/INS post-processing software

Qinertia is a 100% in-house post-processing software solution. This full-featured software enhances SBG Systems inertial navigation systems performance by post processing inertial data with raw GNSS observable in both forward and backward directions.

- Tight Coupling INS/GNSS fusion
- Achieve highest possible accuracy
- + 7,000 Base Stations always up-to-date
- Open to all Industry Standards
- Fastest Processing available on the market
- Modern & Intuitive Interface

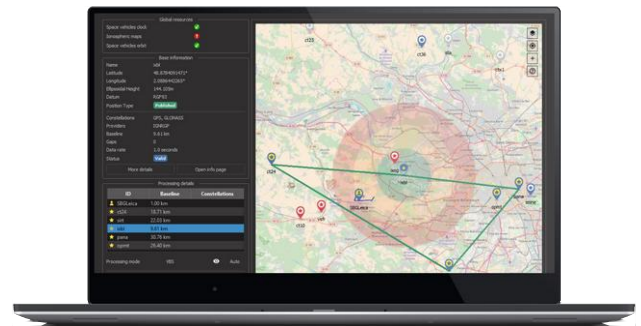

Qinertia offers three different editions to better fit market needs:

- *Qinertia Lite* – Can only process ELLIPSE products for land and air applications
- *Qinertia UAV* – Specific version for UAV market that can process any SBG Systems INS but with a limited radius around the trajectory barycenter.
- *Qinertia Pro* – Full features edition that can process any product for any application including hydrography.

6.2.2. QUANTA DEV KIT

The Development Kit is an essential accessory that provides an easy access to every feature of a Quanta product, thanks to the development board and included cables accessories.

Standard connectors on the dev board can be directly interfaced with your application (DB-9 for serial ports & CAN, RJ-45 for Ethernet, DIL connectors for SYNC In and SYNC Out).

The development kit includes the following accessories

- USB cable (for PORT A connection)
- RJ-45 Ethernet cable
- An AC/DC power supply with international plugs to power the system
- UFL to SMA cable adapter to quickly evaluate Quanta product directly inside your application



Figure 6.1 : Evaluation board



Warning: SBG Systems strongly recommends ordering a QUANTA DEV KIT for initial QUANTA evaluation and integration. SBG Systems will not be able to provide technical support if you don't have access to a QUANTA DEV KIT.

6.2.3. QUANTA IMU CABLE 50CM

This cable provides a direct connection between an external IMU and the QUANTA processing unit. Please remember that this cable can only be used for QUANTA Extra versions and one is included with each shipped QUANTA Extra product.

6.3. GNSS antennas and associated cables

6.3.1. ANT-MAX-M7HCT-A-SMA

This GNSS L1/L2/E5b antenna is particularly adapted for precision UAV applications, thanks to an ultra compact design, low power consumption and no ground plane requirement.

This antenna provides a dual frequency tracking on GPS, GLONASS, GALILEO and BEIDOU.

6.3.1.1. Performance specifications

Parameter	Specification
LNA Gain	30dB
Noise figure	1.5 dB typ. 2 dB max
Power consumption	25 mA
Antenna gain at zenith	GPS L1, GLO L1, GAL E1, BDS B1: 0.5dB GPS L2, GLO L2, GAL E5b, BDS B2: 1.1 dB
Dimensions	Diam: 34mm x 51mm
Connector type	SMA
Weight	25g
Environmental	-40 to +105°C IP67



Figure 6.2 : Helix antenna

6.3.1.2. Mechanical drawing

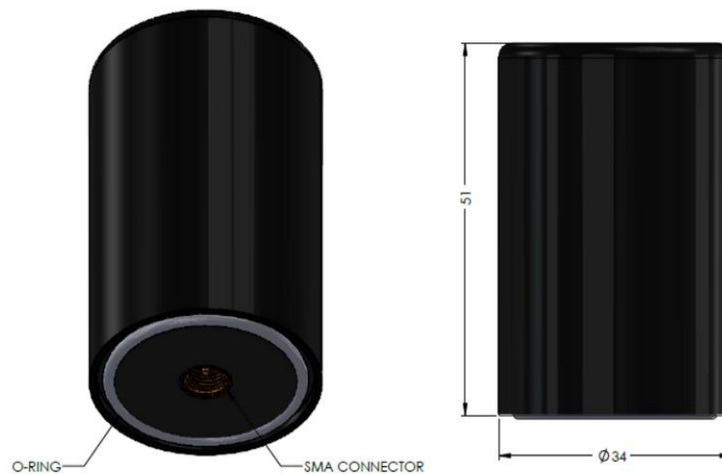

Figure 6.3: Helix antenna mechanical layout. dimensions are in mm

6.3.2. ANT-ACM-G5ANT-1A196MNS-1

This GNSS L1/L2 antenna is especially selected to be compliant with Ellipse-D requirements in both terms of signal tracking and small size / weight.

This antenna provides GPS L1/L2 tracking as well as GLONASS and BEIDOU and GALILEO.

This antenna should be used with a ground plane for optimal performance.

6.3.2.1. Performance specifications

Parameter	Specification
LNA Gain	> 32dB
Noise figure	< 3dB
Power consumption	50 mA
Antenna gain at zenith (100mm ground plane)	GPS L1, Galileo E1: 3.2 dBic GPS L2, Beidou B2: 3 dBic GLONASS L1: 3.6 dB GLONASS L2, Galileo E6, Beidou B3: 2.3 dBic
Dimensions	Square: 50.8 mm Height: 20.45mm
Cable length, type, Connector	5m, RG316B, SMA
Weight	105g (w/o cable), 200g (w cable)
Environmental	-55 to +85°C Hermetically sealed



Figure 6.4 : Antcom G5 antenna

6.3.2.2. Mechanical drawing

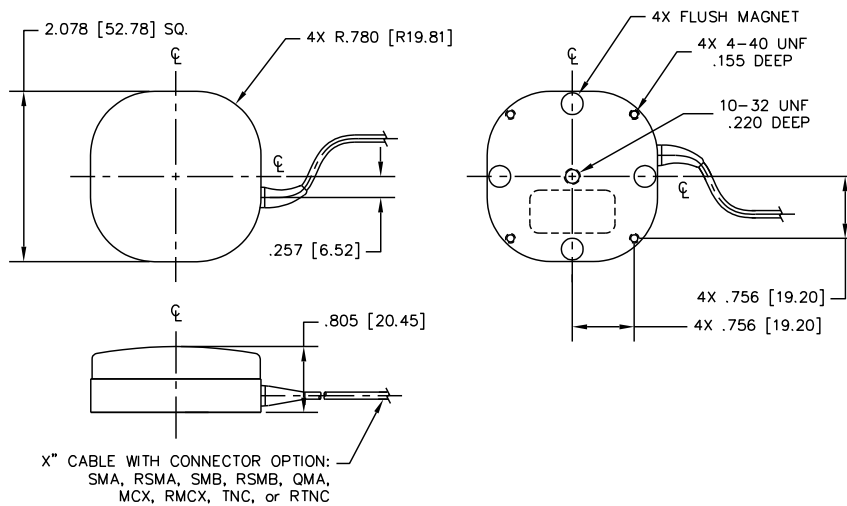

Figure 6.5: Antcom G5 antenna mechanical layout. dimensions are in inches [mm]

7. APPENDIX B: Packaging, labeling

7.1. Board Identification

SBG Systems manufacturing process is based on EN-9100 system with individual and full traceability of every component and operation. Each board is identified by a unique serial number which is used to trace all operations during the product lifetime such as manufacturing, calibration, tests and repairs.

In addition to a unique serial number, a “Hardware Code” and associated hardware revision are used to identify the exact hardware model.

Finally, the “Part Number” is used for logistics purpose. It identifies uniquely the full product configuration, including hardware type, software options, and any software or process customization.

You can find on the top or bottom sides of the boards, laser printed labels that hold the Hardware Code as well as Serial Number and Hardware Revision. These labels also include a data-matrix code that encodes the device unique serial number.

In addition, the board packaging includes a second label that provides other useful information such as exact part number and installed firmware version.

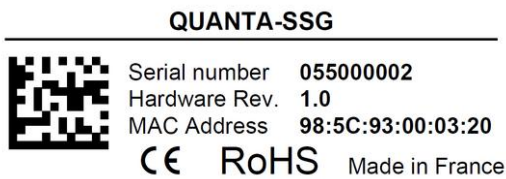

Figure 7.1: Quanta processing module label

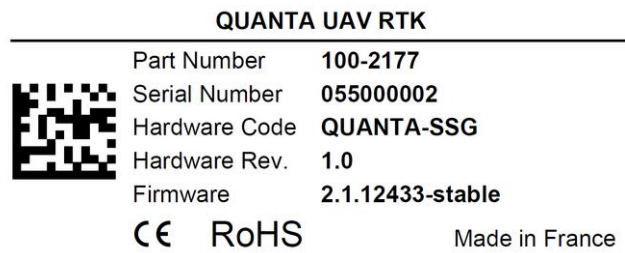

Figure 7.2: Quanta processing module package label

8. APPENDIX C: Safety Information

Warning: ESD Sensitive Devices

Electronic equipment such as discrete components, hybrid devices, integrated circuits, printed circuit assemblies can be permanently damaged or destroyed when near or in contact with electro-statically charged objects.

Normative references:

Standards	Title
EN 61340-5-1 (2016)	Electrostatics. Protection of electronic devices from electrostatic phenomena – General Requirements
EN 61340-5-2(2007)	Electrostatics. Protection of electronic devices from electrostatic phenomena – User guide
IEC 61340-5-3(2015)	Electrostatics, Protection of electronic devices from electrostatic phenomena – Properties and requirements classification for packaging intended for electrostatic discharge sensitive devices

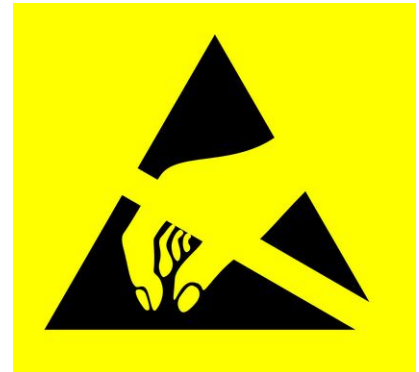

Handling

ESD sensitive devices must be handled only in static-protected environment.

According to reference standards above, each ESD protection equipment such as grounding strap, bench matting, floor matting and ground cord must be tested before handling ESD sensitive devices. In addition, it is strongly recommended to wear ESD smocks during all service procedures.

Transport and storage

ESD sensitive devices are supplied in ESD protective packaging such as ESD shielding bags.

ESD sensitive devices and ESD protective packaging are identified with specific labels.

ESD sensitives devices must be stored in ESD protective packaging before final assembly.

9. APPENDIX D: Environmental Statements

9.1. RoHS statement



Quanta product line comply with European Union (EU) Directive 2002/95/EC on the restriction of the use of certain hazardous substances in electrical and electronic equipment (RoHS Directive).

Conformity reports are available upon request.

9.2. WEEE statement

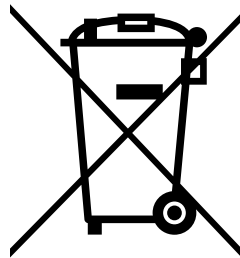

Quanta product line comply with the European Union (EU) Directive 2002/96/EC on waste electrical and electronic equipment (WEEE). The purpose of this Directive is the prevention of waste electrical and electronic equipment, and in addition, the reuse, recycling and other forms of recovery of such wastes so as to reduce the disposal of waste. If purchased in the European Union, please return the products at the end of its life to the supplier from which it was purchased.

10. APPENDIX E: Development board specifications

10.1. Board overview

The evaluation board has been designed to test and configure the Quanta product without any electronics development, thanks to standard connectors and cables.

Following connectors provide easy access to the board functionalities:

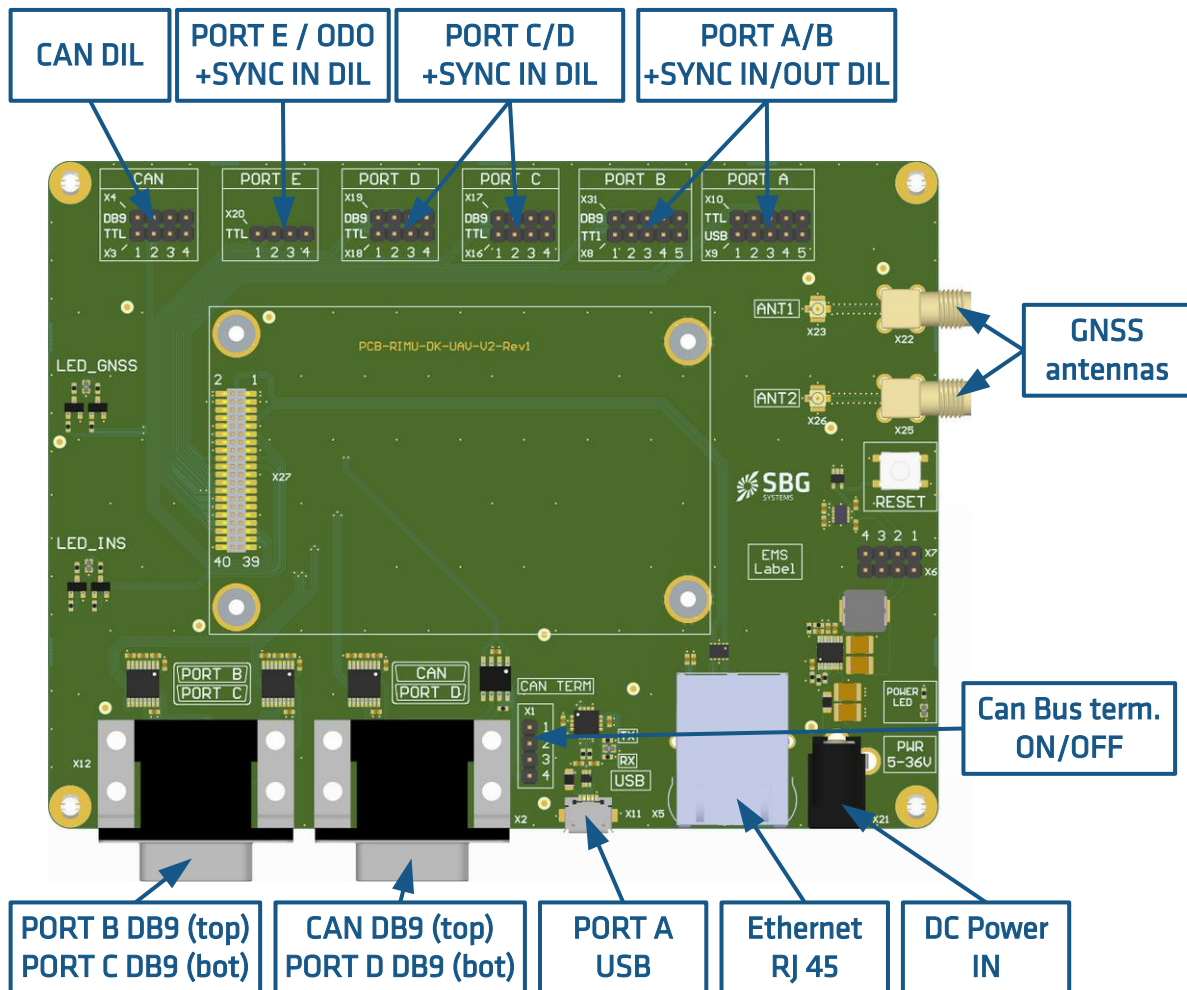

10.2. Interfaces specifications

10.2.1. Power input

The DC 2.1 mm DC jack input supports a wide DC input voltage range [6 - 36V].

Alternatively, for current monitoring purpose, it's possible to directly power on the Quanta system (without powering on the external components). In order to do so, the two jumpers between X6 and X7 should be defined according to the following rule.

- Jumpers between X6 and X7 on position 1 and 2: Internal power supply
- Jumpers between X6 and X7 on position 3 and 4: External power supply. Apply Quanta power supply at XY pin 1 or 2.

10.2.2. Ethernet

Ethernet interface is accessible through the standard RJ-45 connector (X5).

10.2.3. PORT A

By default, PORT A, SYNC IN A and SYNC OUT A are accessible through the USB micro connector available on the evaluation board (X11).

Alternatively, these signals can be directly accessed from the Quanta board using the dedicated DIL connector (X9).

When the jumpers are ON, the access is driven to the USB port. When the jumpers are removed, user can access to the direct Quanta signals with following pin definition:

Pin #	Definition (at TTL side)
1	PORT A TX
2	PORT A RX
3	SYNC IN A
4	SYNC OUT A
5	GND

Quanta electrical specifications apply when accessing directly at the TTL outputs.



Note: Unlike the other SYNC IN / OUT signals, the SYNC IN A and SYNC OUT A polarity is inverted when accessing to the direct TTL version, AND their corresponding USB behavior. Other ports have a reversed polarity in TTL and a normal polarity in the RS-232 DB9 connector.

10.2.4. PORT B

By default, PORT B, SYNC IN B and SYNC OUT B are accessible through the dedicated RS-232 DB-9 plug (X connector available on the evaluation board (X12).

Alternatively, these signals can be directly accessed from Quanta board using the dedicated DIL connector (X8).

When the jumpers are ON, the access is driven to the RS-232 port. The pinout on the DB-9 plug is the following:

Pin #	Definition
1	SYNC IN B
2	PORT B RX
3	PORT B TX
4	SYNC OUT B
5	GND
6-9	N/C

When the jumpers are removed, user can access to the direct Quanta signals with following pin definition:

Pin #	Definition (at TTL side)
1	PORT B TX
2	PORT B RX
3	SYNC IN B
4	SYNC OUT B
5	GND

Quanta electrical specifications apply when accessing directly at the TTL outputs.

SYNC IN and SYNC OUT B have a reverse polarity at the TTL side and a normal polarity at RS-232 side.

10.2.5. PORT C and PORT D

By default, PORT C & D as well as SYNC IN C and D are accessible through their dedicated RS-232 DB-9 plug connector available on the evaluation board (X12 and X2).

Alternatively, these signals can be directly accessed from the Quanta board using the dedicated DIL connector (X19 and X20).

When the jumpers are ON, the access is driven to the RS-232 port.

The pinout on the DB-9 plug is the following:

Pin #	Definition
1	SYNC IN C/D
2	PORT C/D RX
3	PORT C/D TX
4	N/C
5	GND
6-9	N/C

When the jumpers are removed, user can access to the direct Quanta signals with following pin definition:

Pin #	Definition (at TTL side)
1	PORT C/D TX
2	PORT C/D RX
3	SYNC IN C/D
5	GND

Quanta electrical specifications apply when accessing directly at the TTL outputs.

SYNC IN C and D have a reverse polarity at the TTL side and a normal polarity at RS-232 side.

10.2.6. PORT E / Odometer input

The PORT E is an alternative port that can also be used as an odometer input for some applications. It can only be accessed directly at the TTL level, through the DIL connector X15.

The connector has the following pinout:

Pin #	Definition (at TTL side)
1	PORT E TX (Not implemented)
2	PORT E RX / ODO A
3	SYNC IN E / ODO B
5	GND

Note that the ODO A signal and SYNC IN E/ODO B have a reverse polarity while the PORT E RX will behave as a regular TTL UART port.

10.2.7. CAN

CAN bus operation is available by default on the dedicated DB-9 plug (X2) using a standard CAN pin-out as follows:

Pin #	Definition
1	NC
2	CAN_L
3	GND
4-6	GND
7	CAN_H
8-9	NC

A CAN bus termination resistor can be implemented by moving the X1 jumper as follows:

X1 jumper position	Meaning
1-2	120 Ohm Termination OFF
3-4	120 Ohm Termination ON

Alternatively, putting off the X4 jumpers will give access to the direct TTL CAN interface signals.

The pinout at X4 level is the following:

Pin #	Definition
1	CAN TX
2	CAN RX
3	GND
4	GND

10.3. Default switches configuration

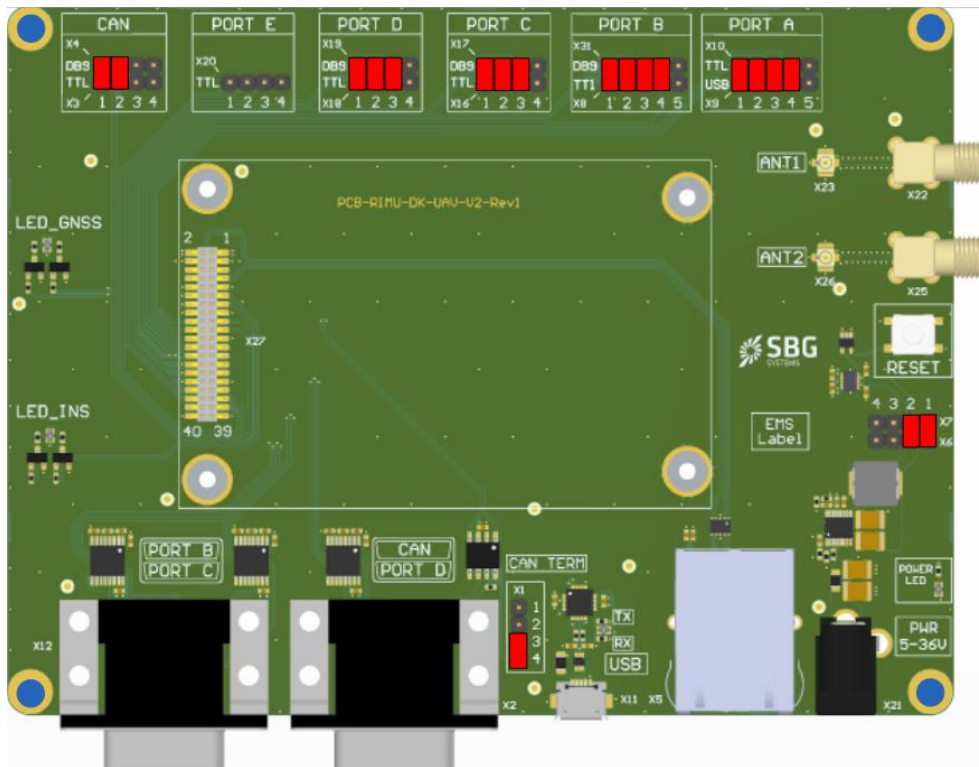

10.4. Schematics

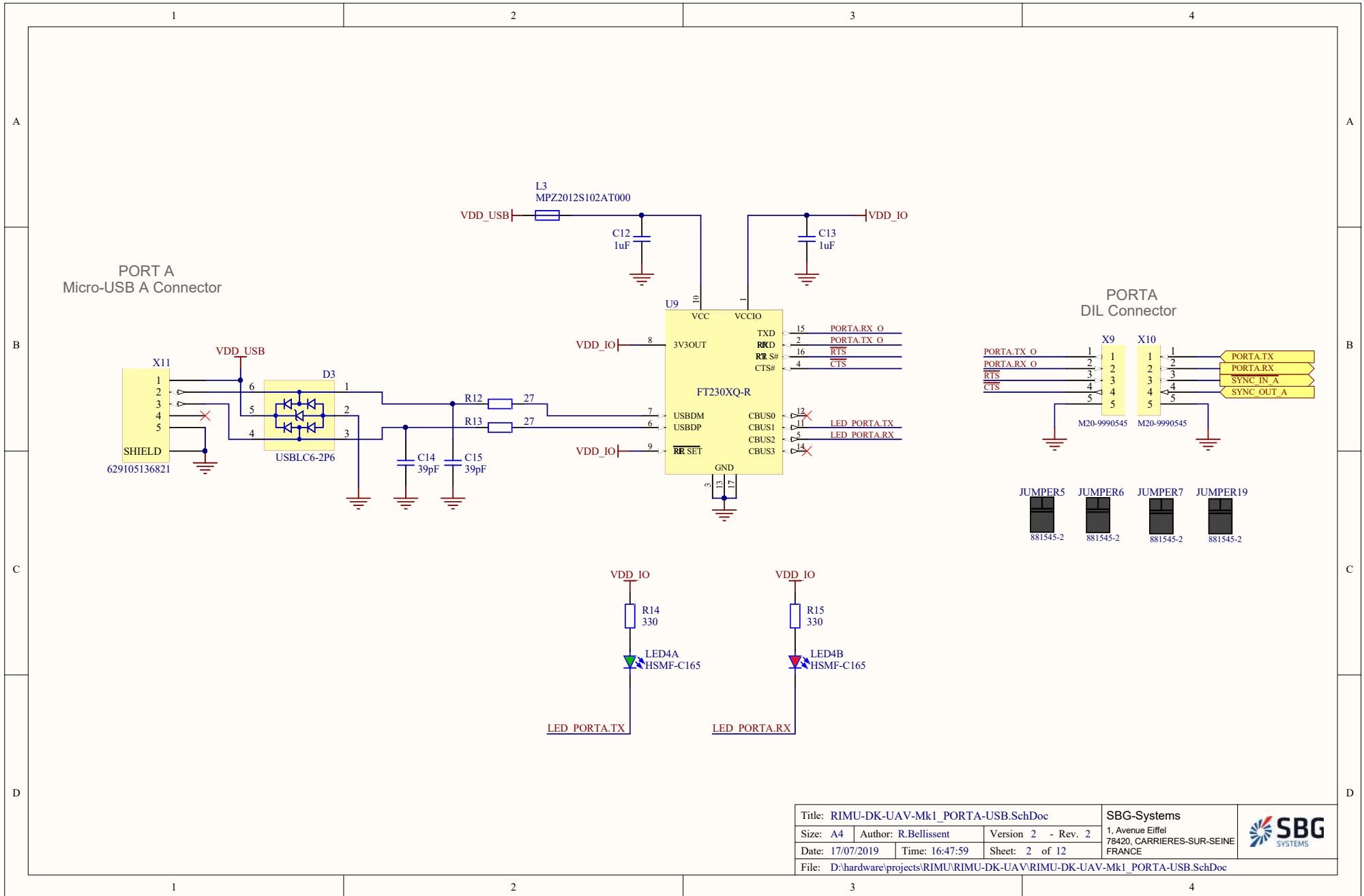

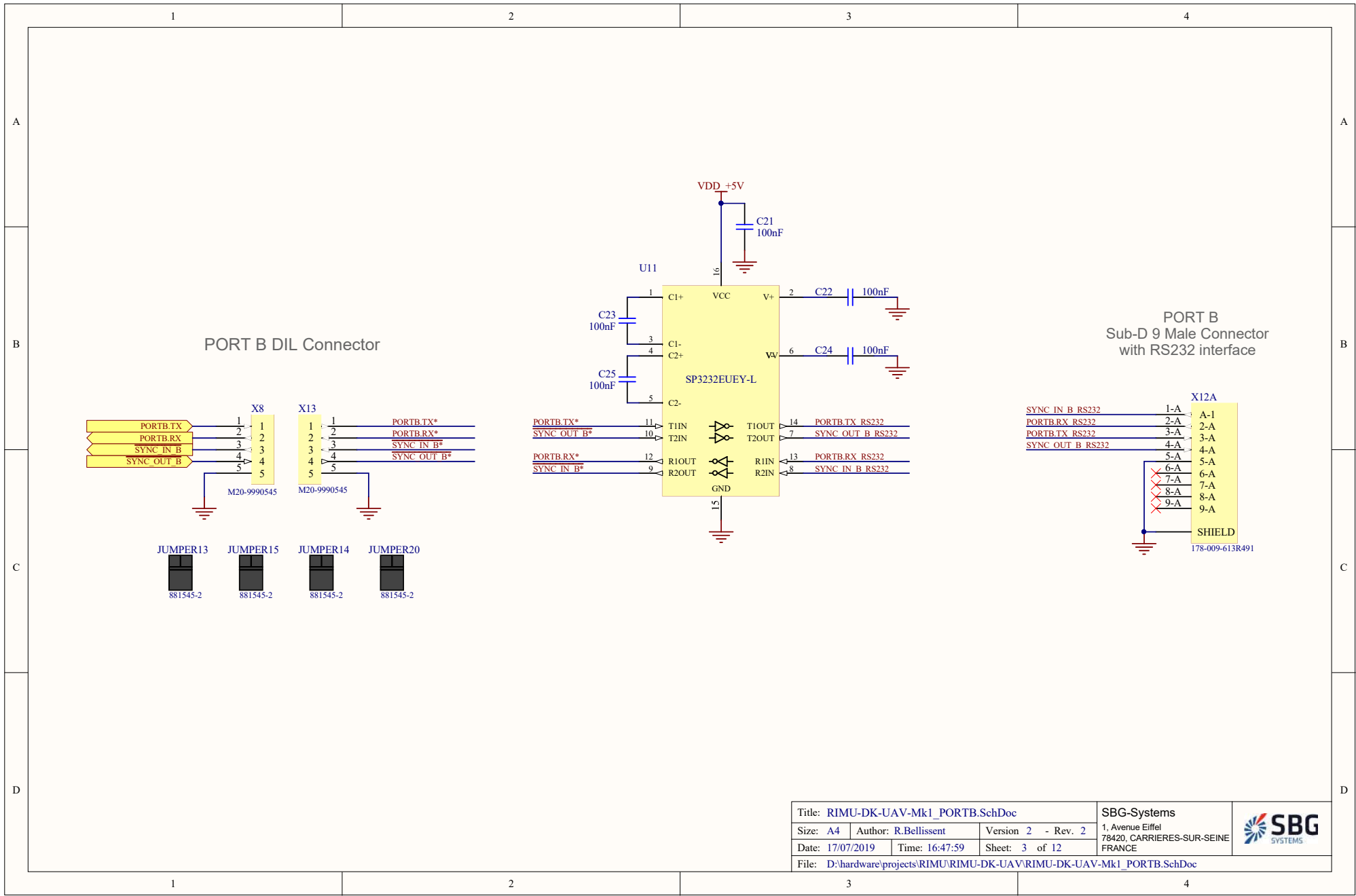

Title: RIMU-DK-UAV-Mk1_PORTB.SchDoc			SBG-Systems 1, Avenue Eiffel 78420, CARRIERES-SUR-SEINE FRANCE	
Size: A4	Author: R.Bellissent	Version 2 - Rev. 2		
Date: 17/07/2019	Time: 16:47:59	Sheet: 3 of 12		
File: D:\hardware\projects\RIMU\RIMU-DK-UAV\RIMU-DK-UAV-Mk1_PORTB.SchDoc				

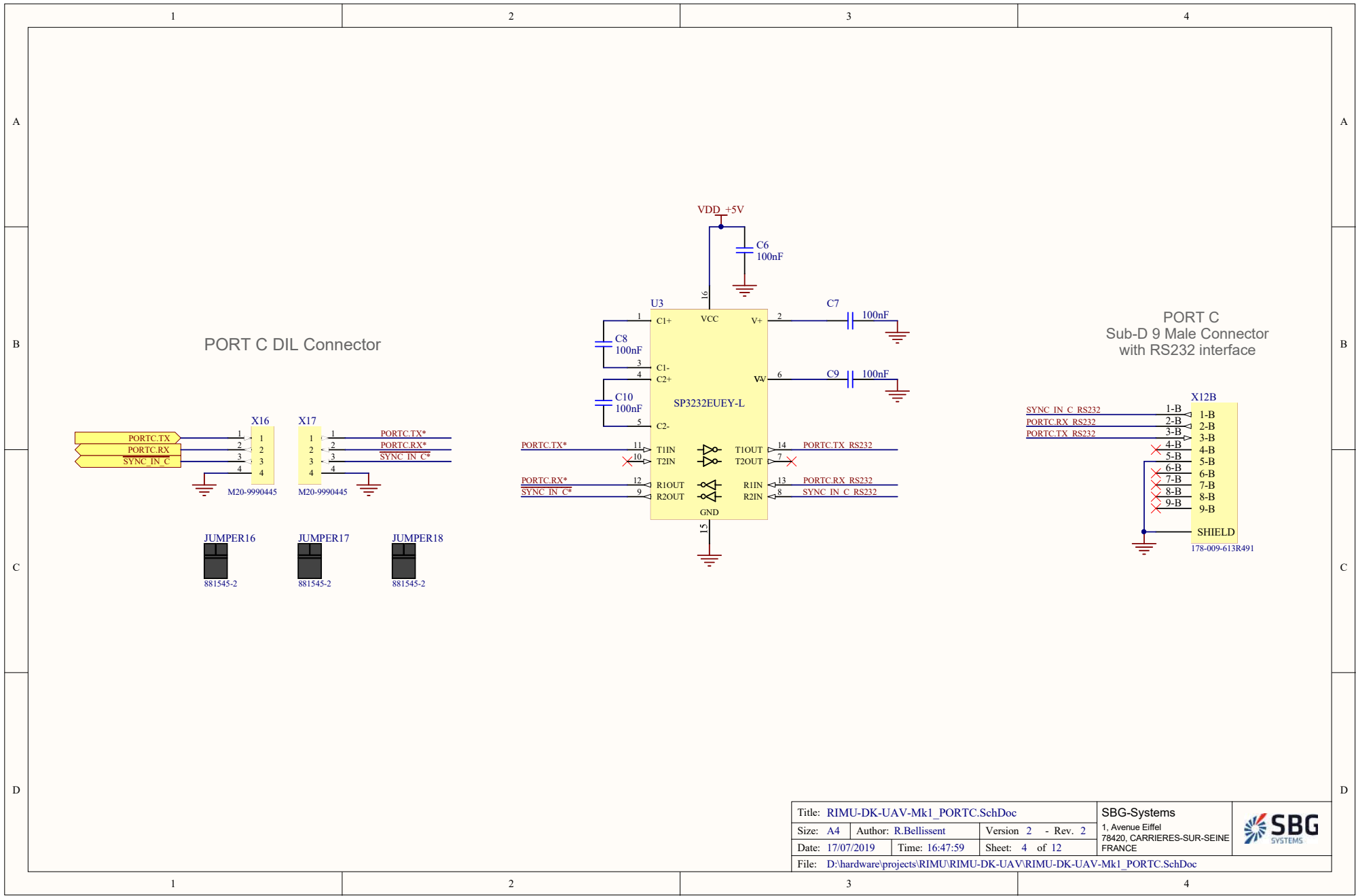

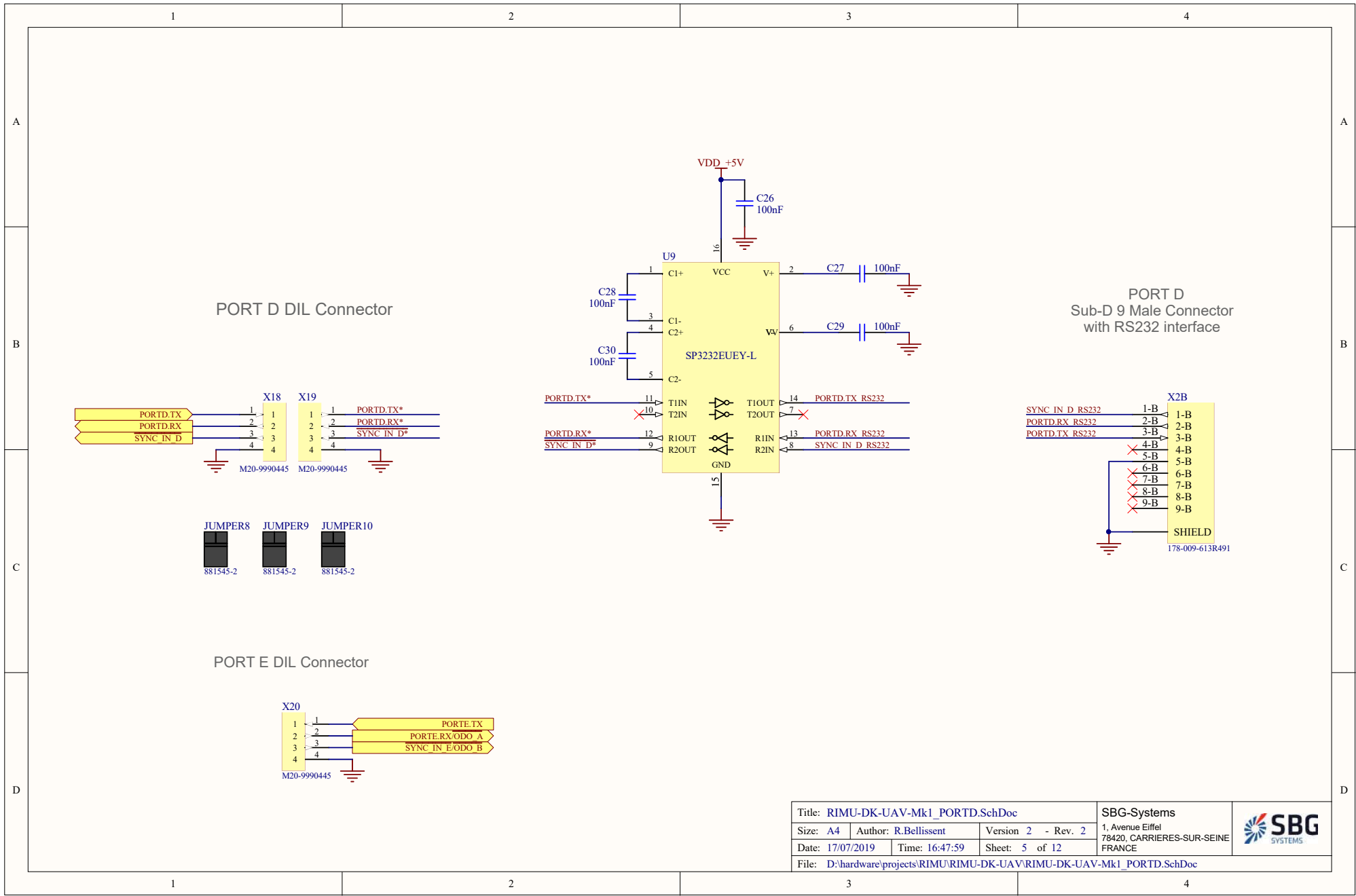

Title: RIMU-DK-UAV-Mk1_PORTC.SchDoc			SBG-Systems 1, Avenue Eiffel 78420, CARRIERES-SUR-SEINE FRANCE	
Size: A4	Author: R.Bellissent	Version 2 - Rev. 2		
Date: 17/07/2019	Time: 16:47:59	Sheet: 4 of 12		
File: D:\hardware\projects\RIMU\RIMU-DK-UAV\RIMU-DK-UAV-Mk1_PORTC.SchDoc				

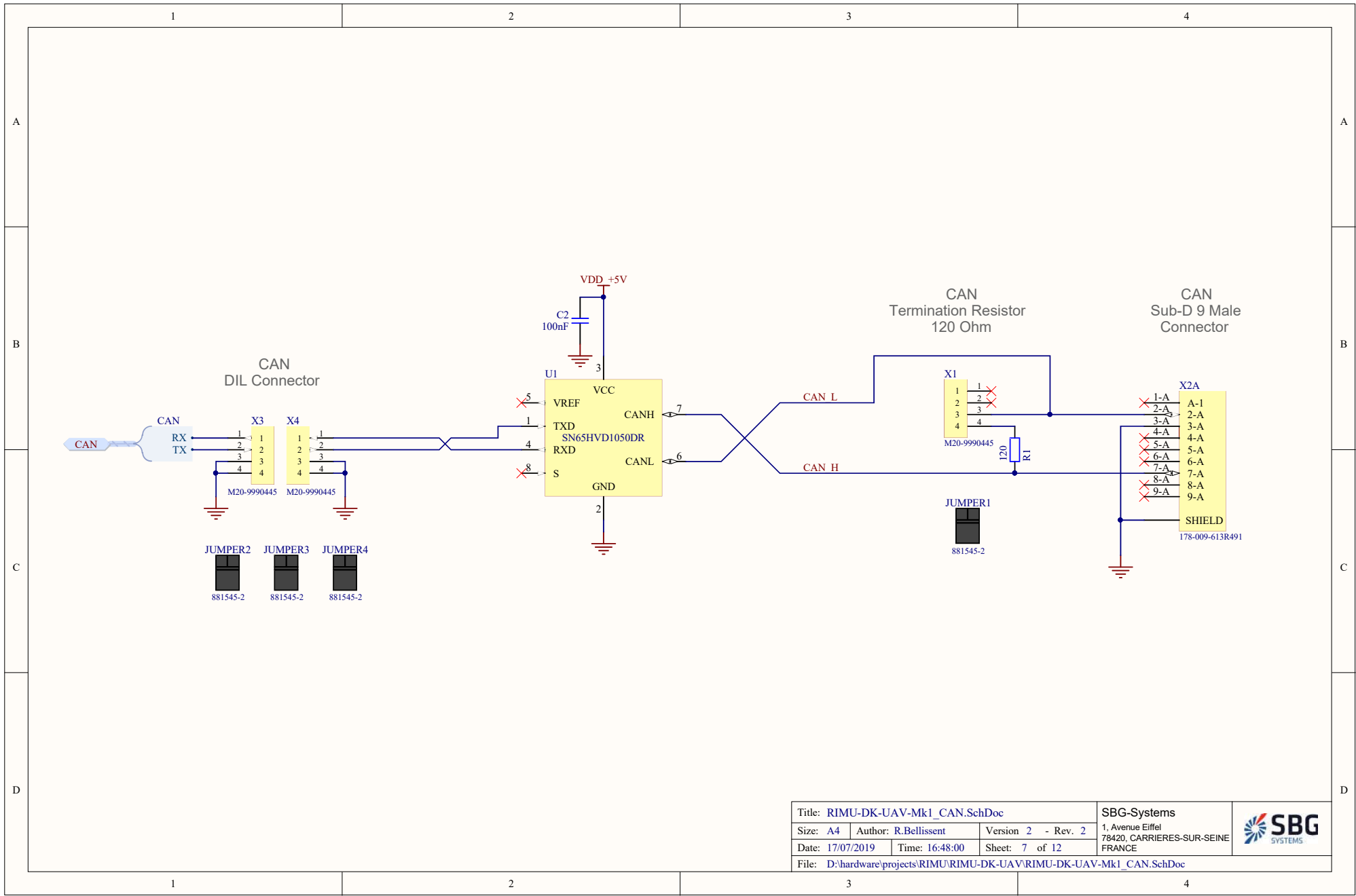



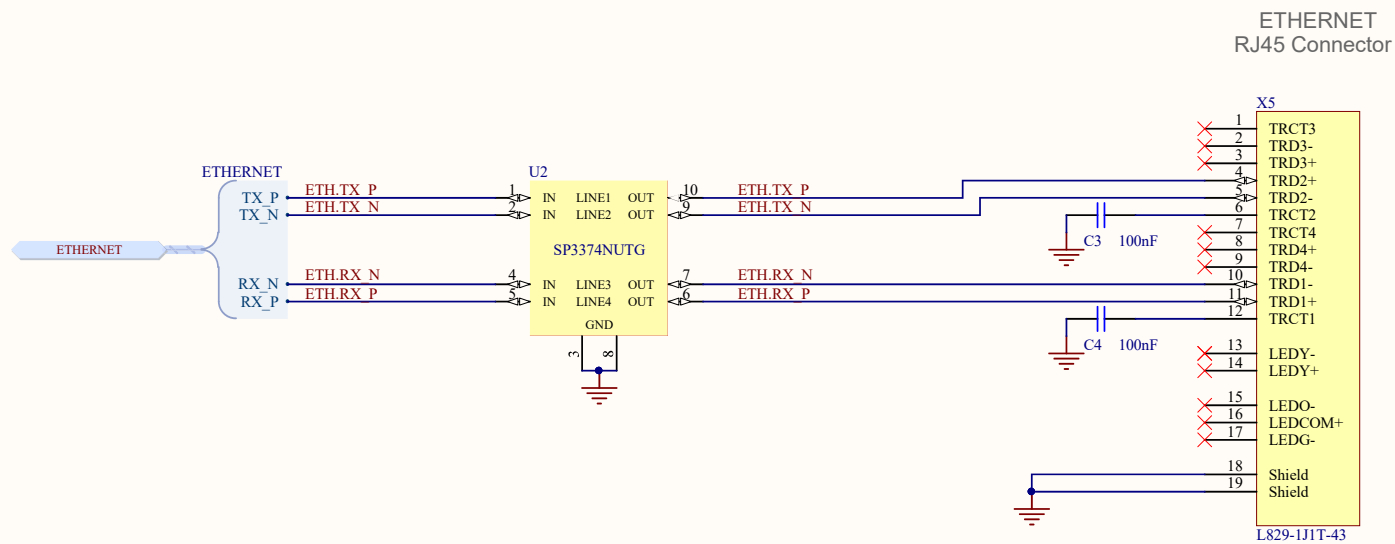

Title: RIMU-DK-UAV-Mk1_CAN.SchDoc			SBG-Systems 1, Avenue Eiffel 78420, CARRIERES-SUR-SEINE FRANCE	
Size: A4	Author: R.Bellissent	Version 2 - Rev. 2		
Date: 17/07/2019	Time: 16:48:00	Sheet: 7 of 12		
File: D:\hardware\projects\RIMU\RIMU-DK-UAV\RIMU-DK-UAV-Mk1_CAN.SchDoc				

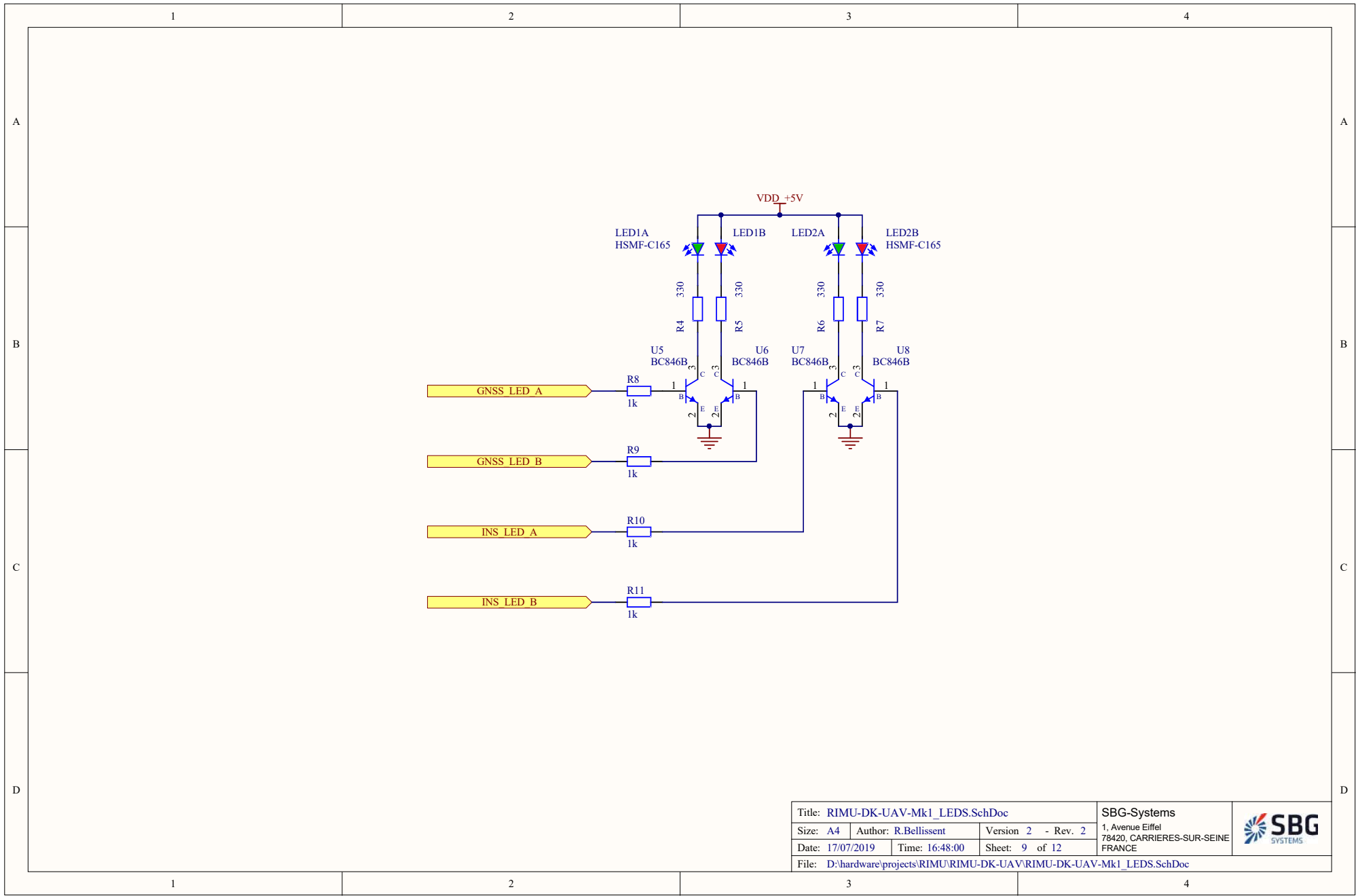

Title: RIMU-DK-UAV-Mk1_ETHERNET.SchDoc			SBG-Systems 1, Avenue Eiffel 78420, CARRIERES-SUR-SEINE FRANCE		
Size: A4	Author: R.Bellissent	Version 2 - Rev. 2			
Date: 17/07/2019	Time: 16:48:00	Sheet: 8 of 12			
File: D:\hardware\projects\RIMU\RIMU-DK-UAV\RIMU-DK-UAV-Mk1_ETHERNET.SchDoc					



Title: RIMU-DK-UAV-Mk1_LEDS.SchDoc			SBG-Systems 1, Avenue Eiffel 78420, CARRIERES-SUR-SEINE FRANCE	
Size: A4	Author: R.Bellissent	Version 2 - Rev. 2		
Date: 17/07/2019	Time: 16:48:00	Sheet: 9 of 12		
File: D:\hardware\projects\RIMU\RIMU-DK-UAV\RIMU-DK-UAV-Mk1_LEDS.SchDoc				

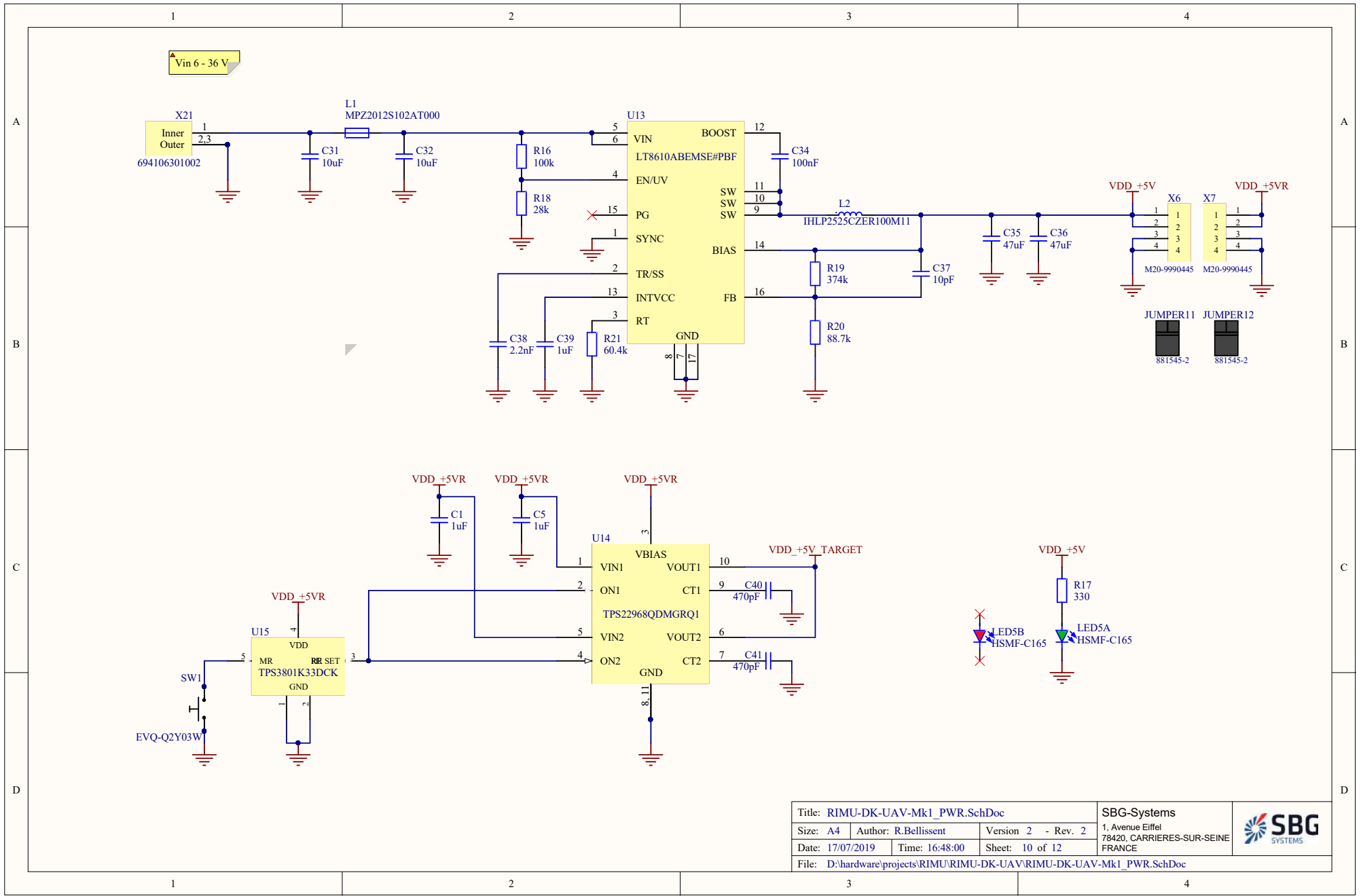

Title: RIMU-DK-UAV-Mk1_PWR.SchDoc			SBG-Systems 1, Avenue Eiffel 78420, CARRIERES-SUR-SEINE FRANCE	
Size: A4	Author: R.Bellissent	Version 2 - Rev. 2		
Date: 17/07/2019	Time: 16:48:00	Sheet: 10 of 12		
File: D:\hardware\projects\RIMU\RIMU-DK-UAV\RIMU-DK-UAV-Mk1_PWR.SchDoc				

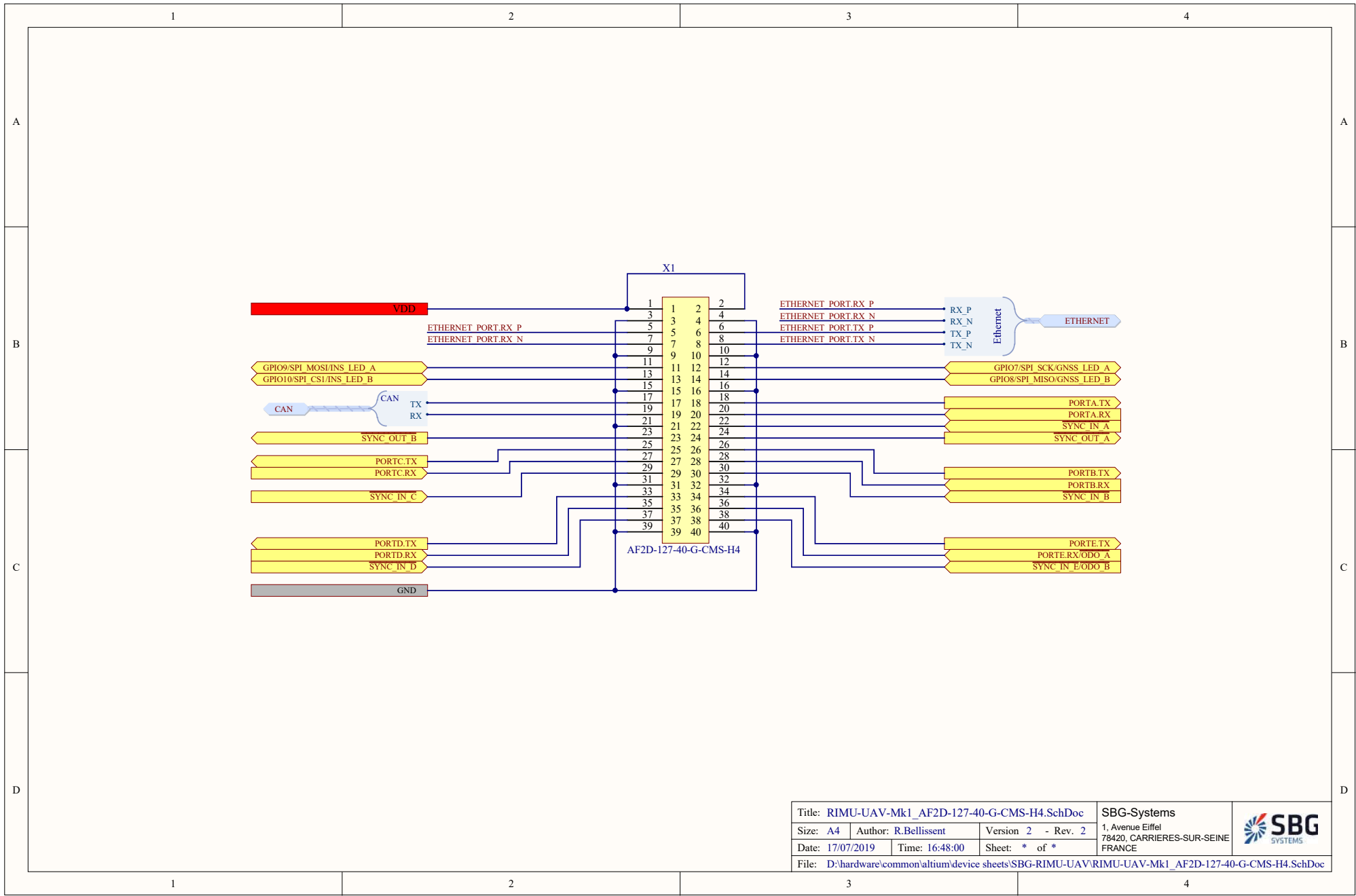

Title: RIMU-UAV-Mk1_AF2D-127-40-G-CMS-H4.SchDoc			SBG-Systems	
Size: A4	Author: R.Bellissent	Version 2 - Rev. 2	1, Avenue Eiffel 78420, CARRIERES-SUR-SEINE FRANCE	
Date: 17/07/2019	Time: 16:48:00	Sheet: * of *		
File: D:\hardware\common\altium\device sheets\SBG-RIMU-UAV\RIMU-UAV-Mk1_AF2D-127-40-G-CMS-H4.SchDoc				