

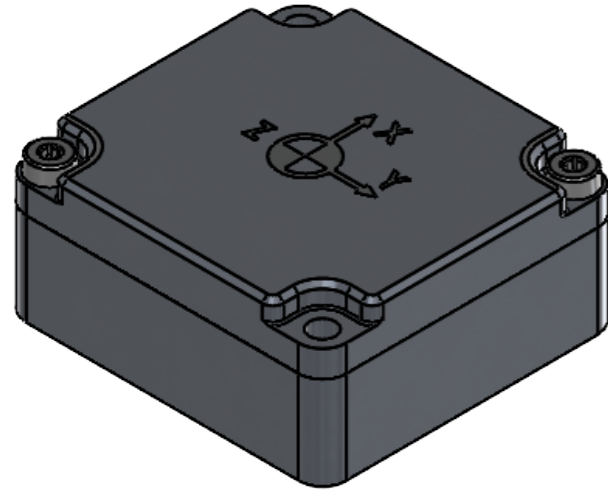

TABLES OF CONTENTS



GENERAL TABLE		
Page	Title	Description
1	Tables of Contents	
2	General Drawing	OEM interface localization
3	Center Of Measurement	Origin point intersection of inertial reference frame from accelerometers
4	Interface Mounting	Principle and type of customer assembly
5	Interface Board	

REVISION TABLE		
Revision	Change	Date
Rev A	Create	2026 03 03

This document is the exclusive property of SBG-Systems and may not be reproduced or communicated to third parties without written authorization.

	Designation : PULSE40-OEM-CUSTOMER-DRAWING		
	Drawing N°: drw-SBG-00001799	Revision: A	Maturity state : In Work
Assembly Part N° : prd-SBG-00017030			
Revision: B			
	Material : N/A	Weight (g) : N/A	Treatment : N/A
TOL. : I SO 2768-1; ISO 22081	Format : A3	Scale : 2:1	Sheet: 1/5

GENERAL DRAWING

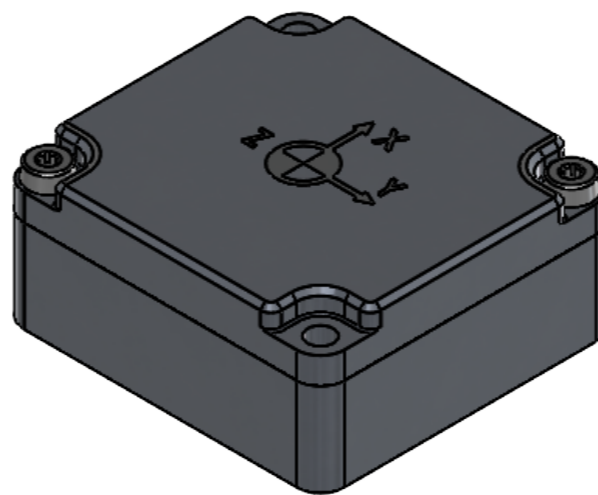
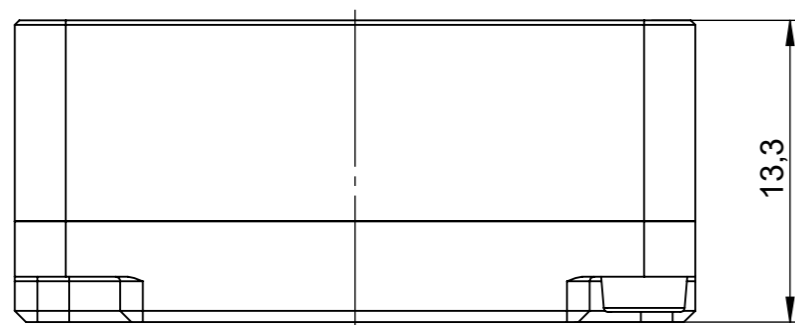
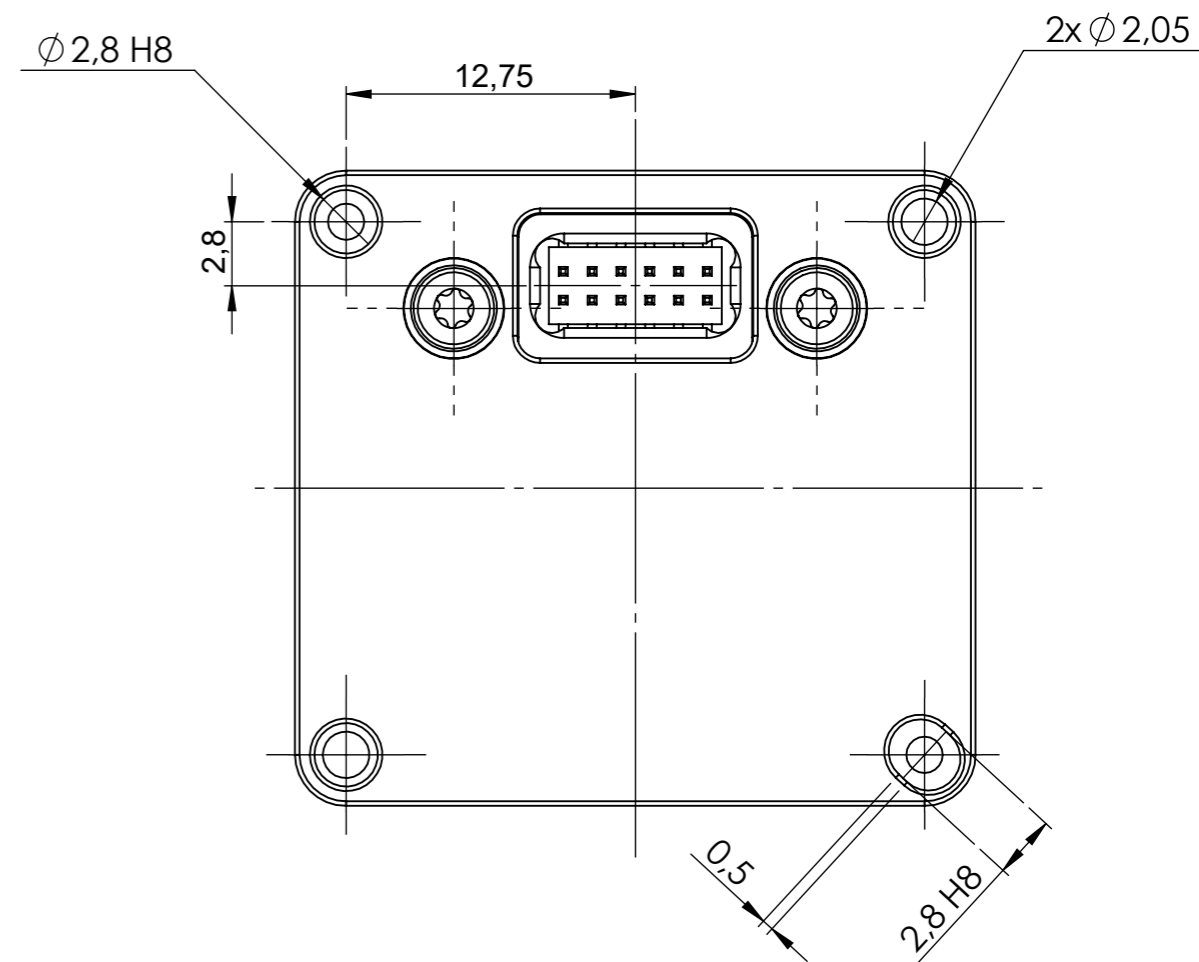
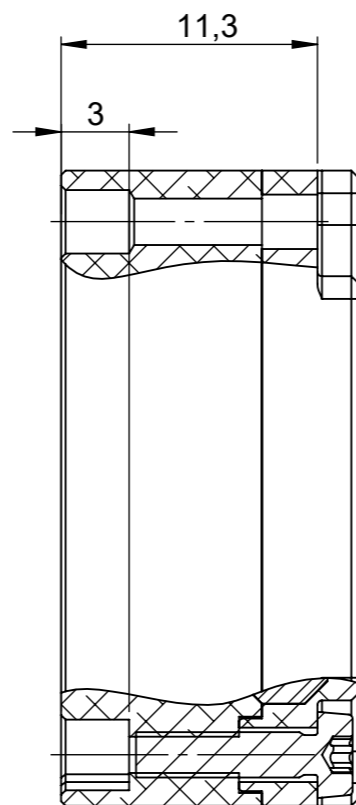
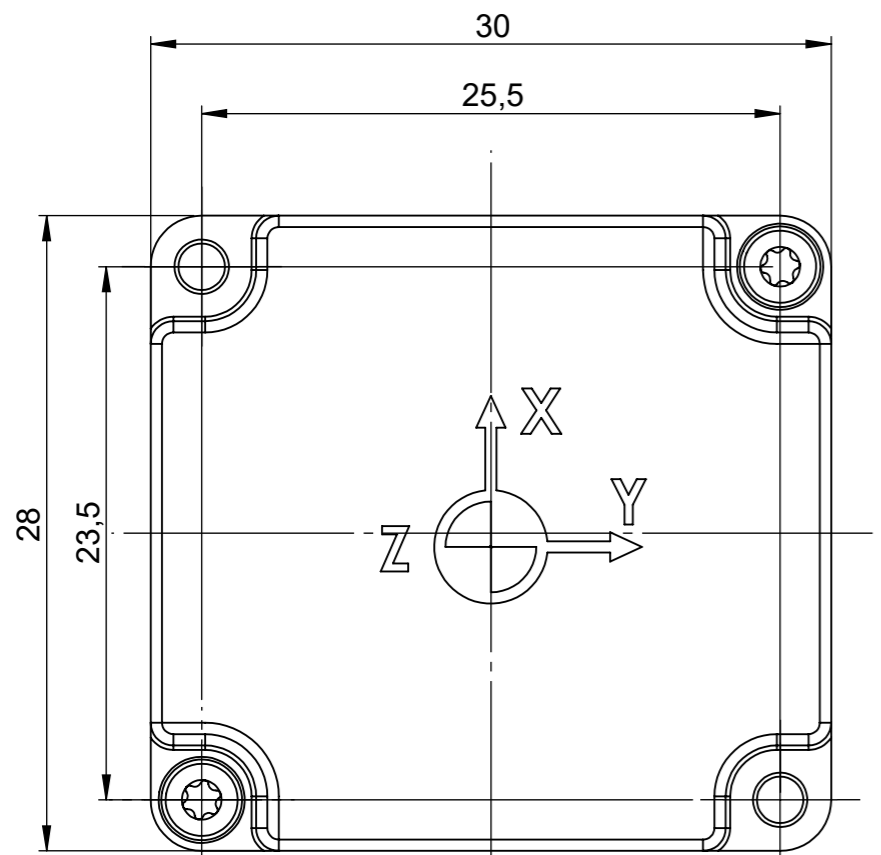

ISOMETRIC VIEW
SCALE 2:1

NOTA : All dimensions are in millimeters

This document is the exclusive property of SBG-Systems and may not be reproduced or communicated to third parties without written authorization.

	Designation : PULSE40-OEM-CUSTOMER-DRAWING		
	Drawing N°: drw-SBG-00001799	Revision: A	Maturity state : In Work
Assembly Part N° : prd-SBG-00017030			
Revision: B			
Material : N/A	Weight (g) : N/A	Treatment : N/A	
TOL. : I SO 2768-1; ISO 22081	Format : A3	Scale : 3:1	Sheet: 2/5



TOL. : I SO 2768-1; ISO 22081 Format : A3 Scale : 3:1 Sheet: 2/5

ORIGIN OF MEASUREMENT

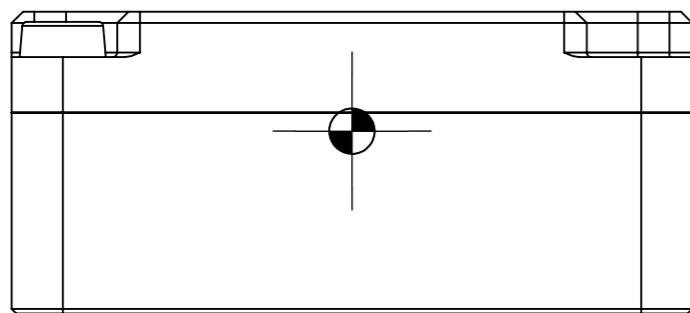

ORIGIN OF MEASUREMENT

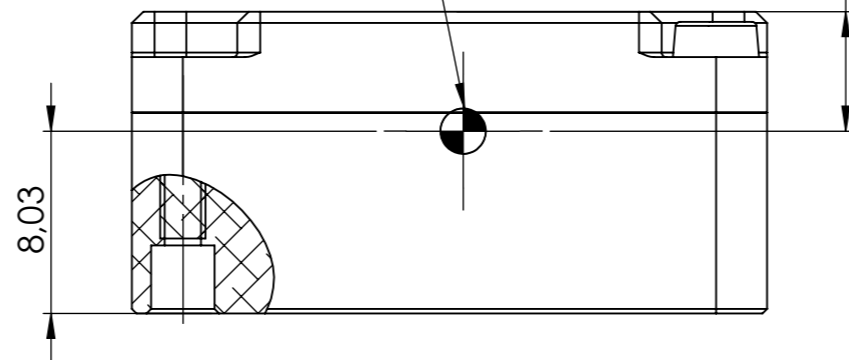

COVER TARGET TO ORIGIN OF MEASUREMENT

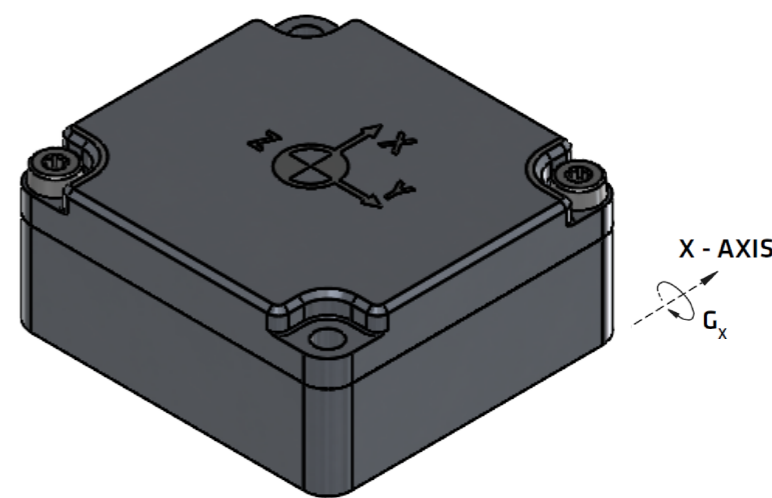
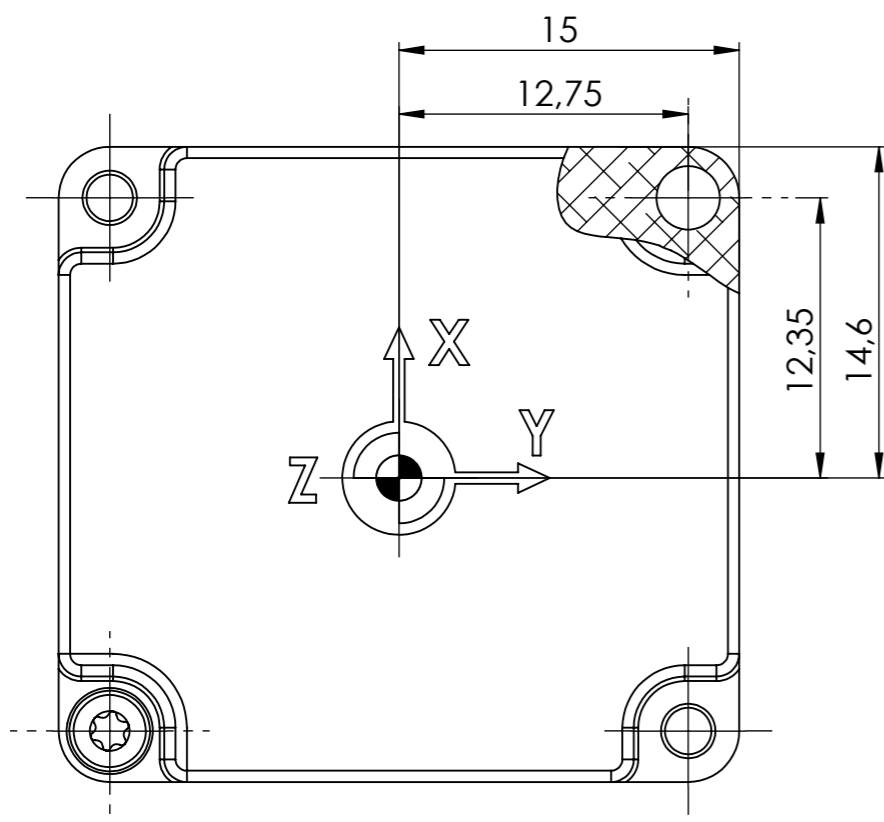

ISOMETRIC VIEW
SCALE 2:1

NOTA : All dimensions are in millimeters

This document is the exclusive property of SBG-Systems and may not be reproduced or communicated to third parties without written authorization.



Designation :
PULSE40-OEM-CUSTOMER-DRAWING

Drawing N°:
drw-SBG-00001799

Revision:
A

Maturity state :
In Work

1 AVENUE EIFFEL
78420, CARRIERE SUR SEINE
FRANCE

Assembly Part N° : prd-SBG-00017030

Revision: B



Material : N/A

Weight (g) : N/A

Treatment : N/A

TOL. : ISO 2768-1; ISO 22081

Format : A3

Scale : 3:1

Sheet: 3/5

EXAMPLE OF MOUNTING INTERFACE

2 x ISO 14580 (A4-70) M2X20 screws
(minimum length required = 20mm)
Recommended torque : 0.22N.m

!! Do not disassemble
this fastener !!

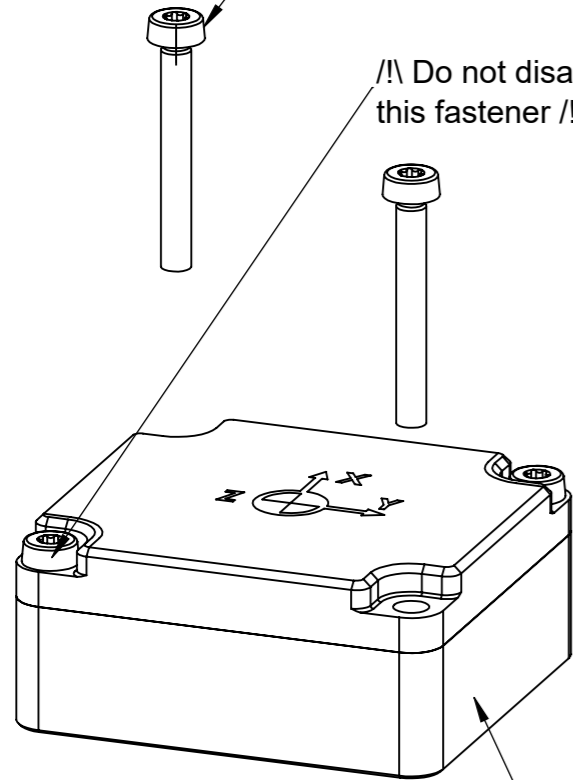

PULSE40-OEM

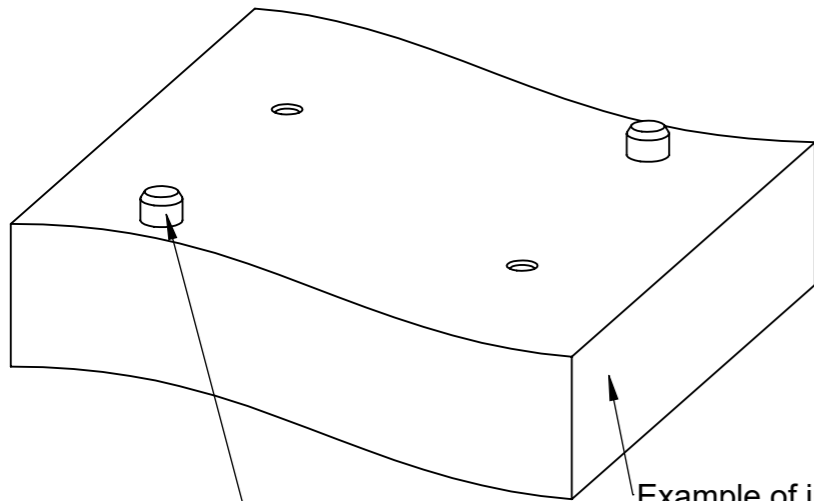

Example of interface

Locating pin Ø2.8 g6
(Can be replaced with indexing)

ISOMETRIC VIEW

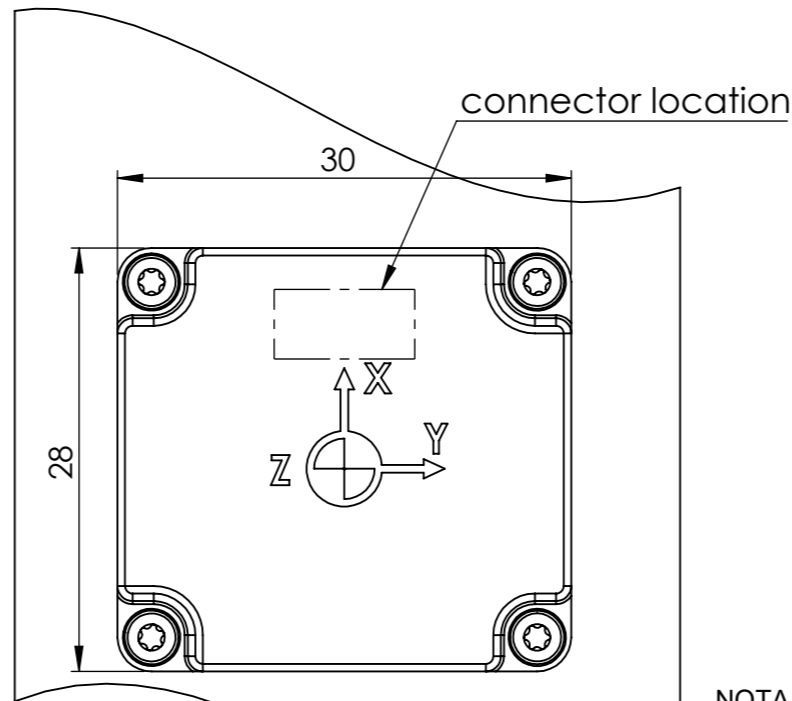
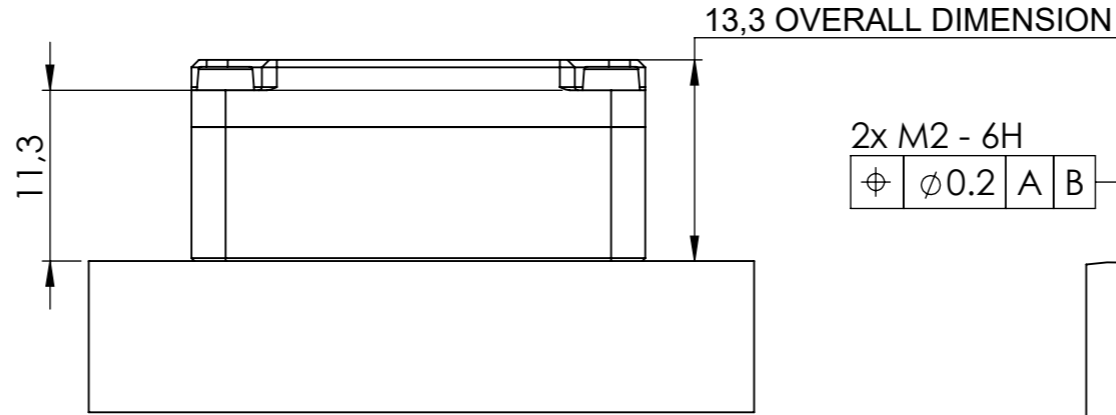

Size	standard pitch (mm)	Inox A4-70 (Nm)	Inox A4-80 (Nm)	Inox A2-70 (Nm)	Inox A2-80 (Nm)
M1.6	0.35	0.11	0.13	0.11	0.13
M2	0.4	0.22	0.26	0.22	0.26
M2.5	0.45	0.45	0.52	0.45	0.52
M3	0.5	0.8	0.95	0.8	0.95
M4	0.7	2.2	2.6	2.2	2.6
M5	0.8	4.3	5.1	4.3	5.1
M6	1	7.5	8.8	7.5	8.8

Indicative values; actual values depend on materials and lubrication

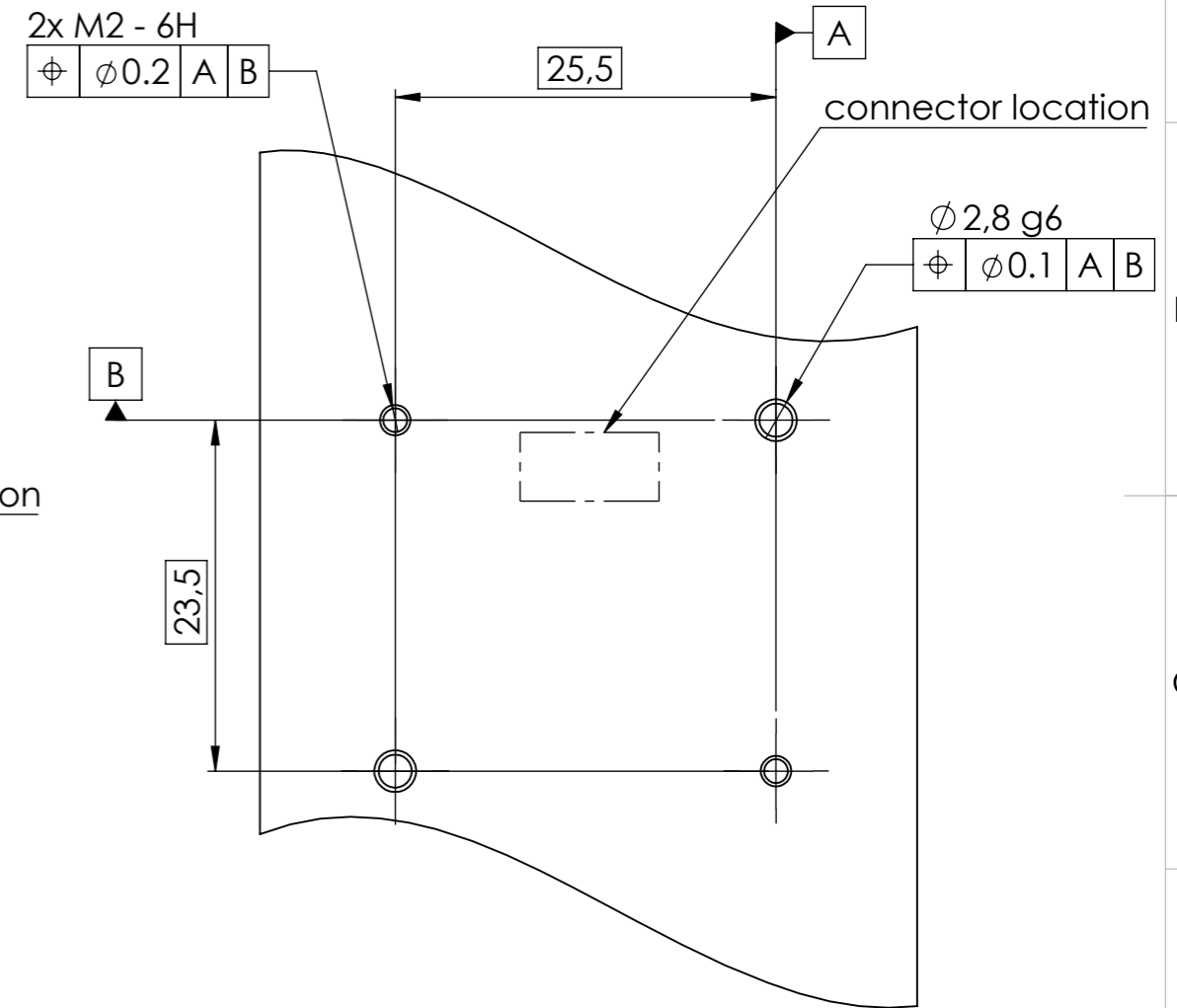

NOTA : All dimensions are in millimeters

This document is the exclusive property of SBG-Systems and may not be reproduced or communicated to third parties without written authorization.



Designation :
PULSE40-OEM-CUSTOMER-DRAWING

Drawing N°:
drw-SBG-00001799

Revision:
A

Maturity state :
In Work

Assembly Part N° : prd-SBG-00017030

Revision: B

1 AVENUE EIFFEL
78420, CARRIERE SUR SEINE
FRANCE



Material : N/A

Weight (g) : N/A

Treatment : N/A

TOL. : I SO 2768-1; ISO 22081

Format : A3

Scalle : 2:1

Sheet: 4/5

MOUNTING INTERFACE BOARD

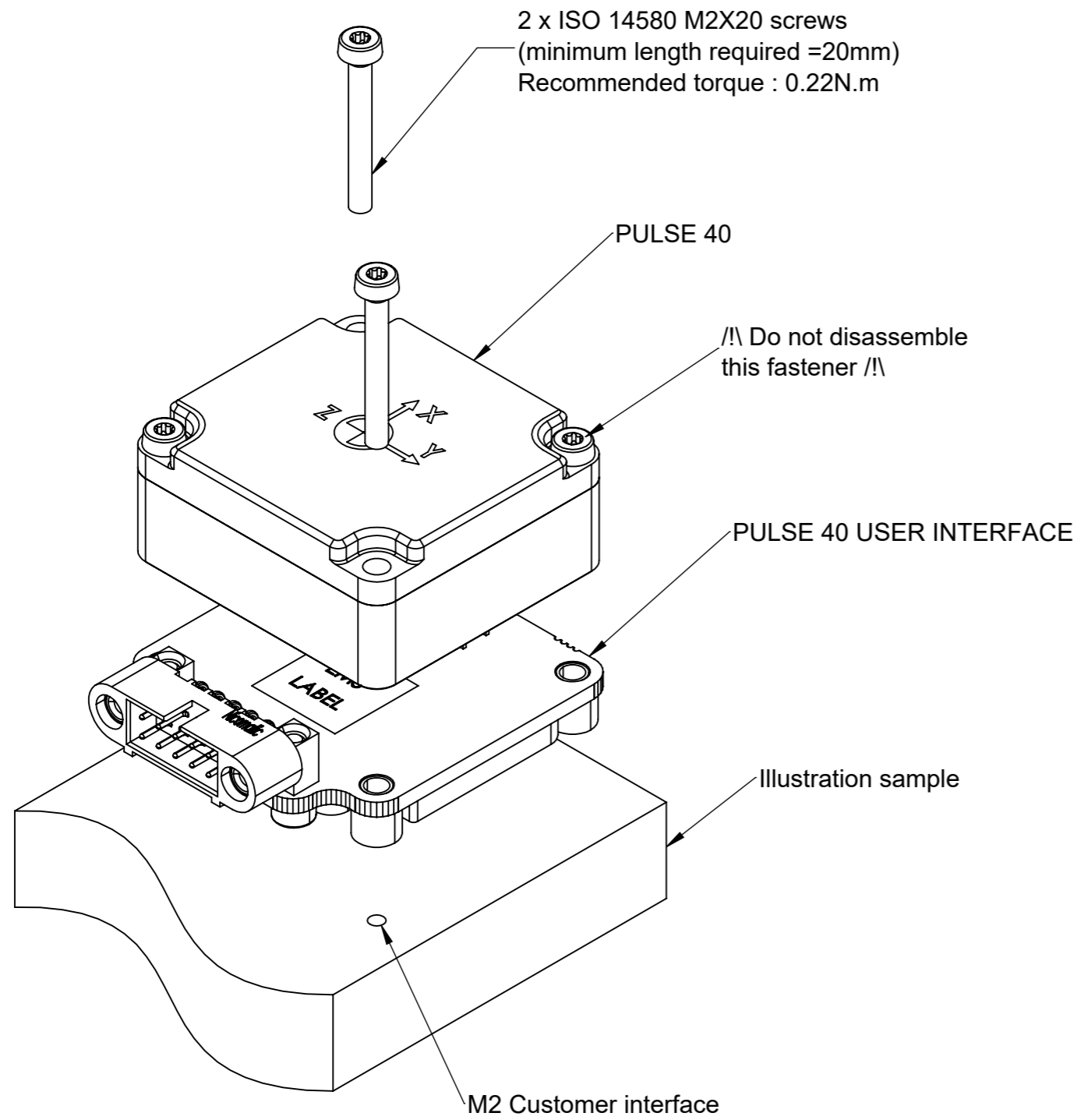

ISOMETRIC VIEW

Size	standard pitch (mm)	Inox A4-70 (Nm)	Inox A4-80 (Nm)	Inox A2-70 (Nm)	Inox A2-80 (Nm)
M1.6	0.35	0.11	0.13	0.11	0.13
M2	0.4	0.22	0.26	0.22	0.26
M2.5	0.45	0.45	0.52	0.45	0.52
M3	0.5	0.8	0.95	0.8	0.95
M4	0.7	2.2	2.6	2.2	2.6
M5	0.8	4.3	5.1	4.3	5.1
M6	1	7.5	8.8	7.5	8.8

Indicative values; actual values depend on materials and lubrication

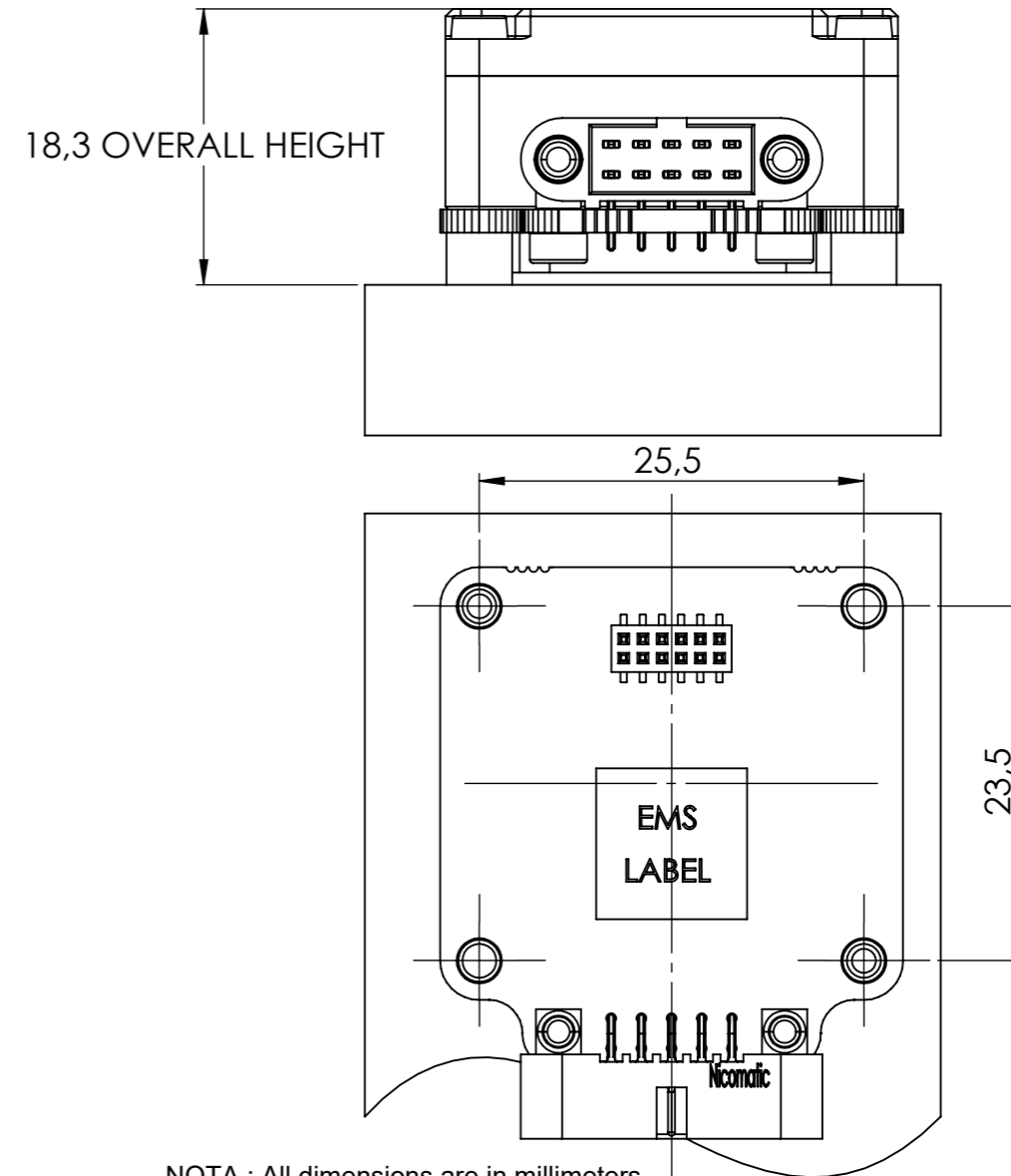

NOTA : All dimensions are in millimeters

This document is the exclusive property of SBG-Systems and may not be reproduced or communicated to third parties without written authorization.

	Designation : PULSE40-OEM-CUSTOMER-DRAWING		
	Drawing N°: drw-SBG-00001799	Revision: A	Maturity state : In Work
Part N° : prd-SBG-00017030			
Revision: B			
Material : N/A	Weight (g) : N/A	Treatment : N/A	
TOL. : I SO 2768-1; ISO 22081	Format : A3	Scale : 2:1	Sheet: 5/5

